

The use of multiplex ARMS-PCR for mutational analysis of beta-globin gene in consanguineous population of KP Pakistan

Ayesha Ghalib

Department of Zoology, Abdul Wali Khan University, Mardan, Pakistan

Valeed Khan

Rehman Medical Institute, Peshawar, Pakistan, and

Sumaira Shams and Ruqiya Pervaiz

Department of Zoology, Abdul Wali Khan University, Mardan, Pakistan

Abstract

Purpose – β -thalassemia is a hereditary disorder due to mutation in the β -globin gene on chromosome 11. Out of 200 known β -globin gene chain mutations recognized, it is better to identify the most common mutation in specific regions and ethnicity for cost-effective molecular diagnosis of this disorder. Therefore, this study aims to practice multiplex-amplification refractory mutation system (ARMS) PCR on patients with thalassaemia in Khyber Pakhtunkhwa (KP) to investigate the most common mutations in the β -globin chain gene.

Design/methodology/approach – Twenty-two individuals (patients, their parents and non-affected siblings) with signed consent were studied from six consanguineous families of β -thalassaemia. Blood samples were collected for DNA isolation. For the detection of mutations in the β -globin gene, ARMS-PCR was used. The amplicon was visualized through 2% Agarose Gel.

Findings – The most common mutations among different ethnic groups in the study area residents were Fr 8-9 (+G) and IVS 1-5 (G> C). The prominent enhancing factors for β -thalassaemia are inter-family marriages and lack of awareness.

© Ayesha Ghalib, Valeed Khan, Sumaira Shams and Ruqiya Pervaiz. Published in *Arab Gulf Journal of Scientific Research*. Published by Emerald Publishing Limited. This article is published under the Creative Commons Attribution (CC BY 4.0) licence. Anyone may reproduce, distribute, translate and create derivative works of this article (for both commercial and non-commercial purposes), subject to full attribution to the original publication and authors. The full terms of this licence may be seen at <http://creativecommons.org/licences/by/4.0/legalcode>

The authors are thankful to Rehman Medical Institute for providing the resources to Ayesha Ghalib to conduct this study under the supervision of Valeed Khan.

Author contributions: Ayesha Ghalib conducted research under the supervision of Valeed Khan and Sumaira Shams. She also drafted the manuscript including all figures and tables. Ayesha Ghalib, Valeed Khan, Sumaira Shams, and Ruqiya Pervaiz approved the final version for publication.

Corrigendum: It has come to the attention of the publisher that the article Ghalib, A., Khan, V., Shams, S. and Pervaiz, R. (2024), "The use of multiplex ARMS-PCR for mutational analysis of beta-globin gene in consanguineous population of KP Pakistan", *Arab Gulf Journal of Scientific Research*, Vol. 42 No. 3, pp. 714-721. <https://doi.org/10.1108/AGJSR-01-2023-0016>, did not report the details of the ethics approval or informed consent for this research within the body of the manuscript. This research was conducted following the ethical guidelines set forth by the Declaration of Helsinki. Prior to commencing data collection, informed consent was obtained from the participants, and they all were provided with detailed information about the study's purpose, procedures, and their rights; their participation was entirely voluntary. The confidentiality of the participants was upheld throughout the study. The study protocol was approved by the Research Ethics Committee of Rehman College of Allied Health Sciences on 13 December 2021 and by the Advanced Study Research Board (ASRB /Dir/A&R/AWKUM/2022/9396) committee members of Abdul Wali Khan University Mardan, Khyber Pakhtunkhwa, Pakistan. The authors sincerely apologize for this mistake.



Practical implications – Multiplex ARMS-PCR is the most valuable technique for assessing multiple mutations in a single reaction tube.

Social implications – Due to extensively found ethnic and regional variations and a high rate of consanguinity, the Pashtun population has a great risk of mutations in their genome. Therefore, ARMS-PCR is a cost-effective mutational diagnostic strategy that can help to control disease burden.

Originality/value – Limited studies using ARMS-PCR for mutational analysis in the β -globin gene are conducted. This study is unique as it targeted consanguineous families of KP Pakistan.

Keywords Mutational analysis, β -Thalassemia, Consanguinity, ARMS-PCR, Khyber Pakhtunkhwa

Paper type Research paper

1. Introduction

“Thalassemia” is comprised of two *Greek* words “*Thalassa*” means sea, and “*Haema*” means blood. It goes for the disorders found in the gene represented as α - and β -globin genes that result in the synthesis of defective α - and β -haemoglobin subunits (Rachmilewitz & Giardina, 2011). The word hemoglobinopathies is a large set of disorders related to hemoglobin, characterized by complete, absent or reduction in the production of one or more of the globin chains such as α , β , γ and δ (Weatherall & Clegg, 2001). Inheritable blood diseases, i.e. β -thalassemias, are identified because of the reduced or missing synthesis of the β -globin chain, which reduces hemoglobin levels in red blood cells (RBCs). Furthermore, low RBC production cause life-threatening anemia and individuals with such disorders need lifetime transfusions for survival. The β -thalassemia carrier condition, developed from β -thalassemia heterozygosity, is medically asymptomatic and is described by certain hematological features (Cao & Galanello, 2010).

Pakistan has a population of approximately 180 million, and more than 5% of this population are β -thalassemia carriers which are 9 million in the whole country (Hafeez, Aslam, Ali, Rashid, & Jafri, 2007). In Pakistan, almost all the mutations of β -thalassemia have been reported previously, enlightening 21 β -globin mutant gene variants. Although, other mutations reported in Pakistan are IVS1-5(GC), Fr 8-9(+G), Fr 41-42(-TTCT), IVS1-1(G-T), Del 619bp, Cd 5(-CT), Fr 16 (-C), Cd 30(G-C), Cd 30(G-A), IVSII-1 (G-A), Cd 15 (G-A) and Cap+1(A-C). Only five mutations among these mutations contribute to about 86% of the total molecular variabilities in Pakistan (Jalil *et al.*, 2019). Approximately, 20 reported mutations hold to be 90% of β -globin genes worldwide (Ansari *et al.*, 2011). In Pakistan, 5,000–9,000 children are born with β -thalassemia annually, although there is a lack of a properly documented registry (Ahmed, Saleem, Modell, & Petrou, 2002).

Recently, several techniques, including PCR-based methods, have been used to diagnose known and unknown globin gene mutations. Until now, about 200 β -thalassemia mutations are known, among which the majority are single-nucleotide substitutions, insertions or deletions of short sequences (Higgs, Engel, & Stamatoyannopoulos, 2012). Fortunately, very few point mutations are common in populations of different ethnicities. PCR method can identify more than 80% of cases for most ethnic groupings. Some laboratories also employ the ARMS (amplification refractory mutation system). For the detection of numerous mutations at the same time, our mutation identification approach is rapid, reasonable and convenient. Sanger *et al.* reported the initial approach in 1977. This approach has been updated, and other automated sequencers are now available. By using direct sequencing, these automated sequencers can detect undiscovered mutations (Traeger-Synodinos & Harteveld, 2014).

For controlling disease burden in a population of low-middle-income countries such as Pakistan, cost-effective diagnostic methods are required. Pashtuns, being the most consanguineous population of the KP province, has a great risk of genetic diseases (Pervaiz, Faisal, & Serakinci, 2018). Therefore, this study aims to use ARM-PCR for the mutational analysis of the beta-globin gene in the consanguineous families of the Pashtun population of KP Pakistan.

2. Materials and methods

2.1 Study sample

In this descriptive cross-sectional study, six consanguineous families were selected, and at least four blood samples were collected (from each family's father, mother and a normal and affected offspring). Patients who had been diagnosed with β -thalassemia are included in the sample collection. In contrast, those who had recently received blood transfusions for at least one week and those with other transfusion-dependent anomalies were excluded.

2.2 Laboratory procedure

Through proper consent from the families, questionnaires were filled from those fulfilling our inclusion criteria. Following the Clinical Laboratory and Standard Institute (CLSI) guidelines, the blood collected was about 5 ml in EDTA-coated vacutainers with tube holders and transferred to the laboratory in a temperature-maintained cold chain. The blood was mixed vigorously with the help of a vortexer. A 200 μ l of whole blood sample was taken from each and 300 μ l lysis solution was added to all labeled tubes. DNA was extracted by Spin-column DNA-extracted method. The DNA quality was assessed by passing it across a 2% agarose gel and quantifying it using a Gel Doc imaging instrument. The DNA was validated using the program GELDOC, and primers were designed for each mutation of β -thalassemia included in our study. ARMS-based PCR primers were designed using the primer three-plus program. The details of primers are given in Table 1.

3. Results

3.1 Clinical description

The present study comprises six Pashtun consanguineous families (A-F) diagnosed with β -thalassemia major from different regions of Khyber Pakhtunkhwa province of Pakistan. These families were selected for the mutation analysis of the HBB gene causative for β -thalassemia. First, these families were initially undergone through different evaluation processes that included brief family history, clinical features and genetic analysis. A detailed clinical description of the probands of these families is explained further.

Family A (Figure 1a) enrolled from Kohat Road Peshawar consisted of four generations comprising two unaffected males (IV-1, IV-2), one affected male (IV-3), two unaffected females

Primer name	Sequence 5'-3'	No. of bases	Product sizes	Melting temp.
FR8/9-Forward	ACCTCACCTGTGGAGCCAC	20	214	64.8
FR8/9-Reverse M	CCTTGCCCCACAGGGCAGTAACGGCACC	30	214	74.8
FR41/42-Forward	ACCTCACCTGTGGAGCCAC	20	448	64.8
FR41/42-Reverse M	GAGTGGACAGATCCCCAAAGGACTCAACCT	30	448	67.8
IVS1G >	ACCTCACCTGTGGAGCCAC	20	281	64.8
T-Forward				
IVS1G >	TTAAACCTGTCTTGTAACCTTGATACGAAA	28	281	56.4
T-Reverse M				
IVS 1-5 G >	ACCTCACCTGTGGAGCCAC	20	285	64.8
C-Forward				
IVS 1-5 G >	CTCCTTAAACCTGTCTTGTAACCTTGTTAG	28	285	58.5
C-Reverse M				
CAP+1 A >	AAAAGTCAGGGCAGAGCCATCTATTGGTTC	24	596	66.6
G -Forward				
CAP+1 A >	CCCCTTCATGACATGAACTTAA	30	596	60.6
G -Reverse M				

Table 1.
Primers and their sequences used in amplification of the product

Source(s): By authors (Ms Ayesha Ghalib under the supervision of Dr Waleed)

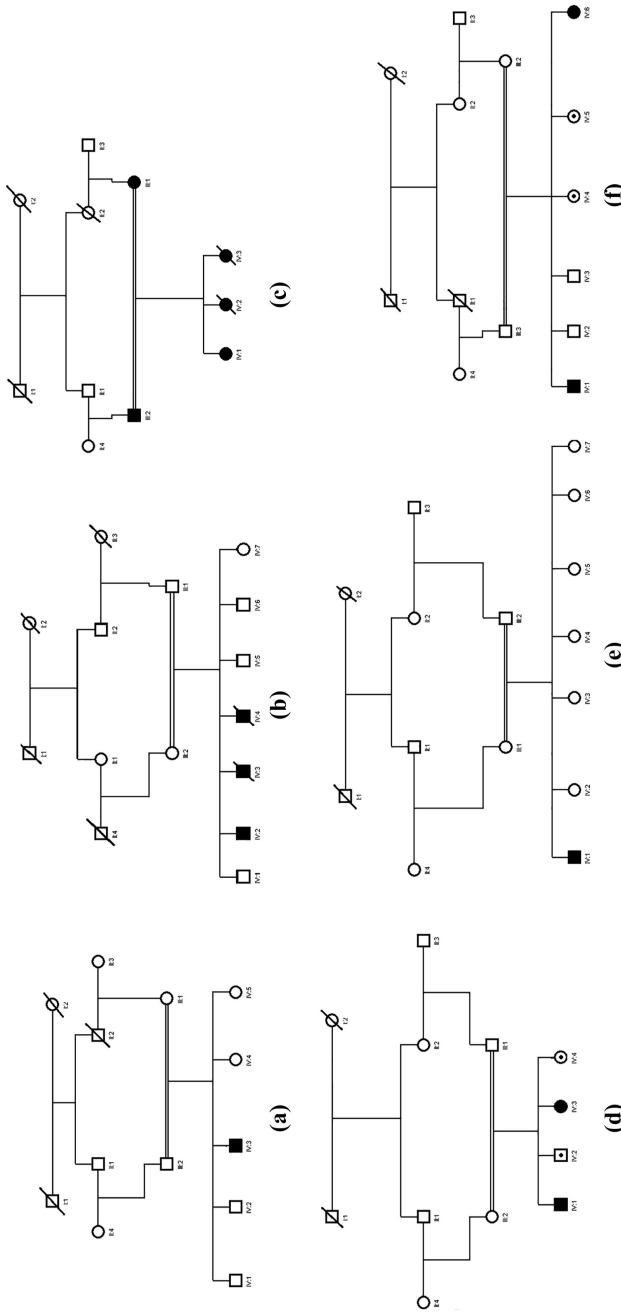

Notes(s): Roman symbols I, II, III, and IV represent generation numbers. The circles denote females, while the squares denote males. The double lines represent the consanguinity union, and the Arabic letters 1, 2, 3, etc., are the person numbers. The blocked circles and squares represent the cases with β -thalassaemia. The circle with a dot represents the carrier female, while the square with a dot is the carrier male

Source(s): By authors (Miss. Ayesha Ghalib under supervision of Dr. Waleed)

Figure 1. A, B, C, D, E and F represent the pedigrees of families A, B, C, D, E and F, respectively

(IV-4, IV-5) and parents (III-1, III-2) who were in single consanguineous loop paternal cousins. Samples of blood were collected from parents (III-1, III-2), one affected male (IV-3) and one unpretentious female (IV-4).

Family B (Figure 1b) was recruited from Peshawar and consisted of nine members, including the affected one. The family consists of a consanguineous loop of both maternal and paternal cousins. The family consisted of four generations in which three males were affected (IV-2, IV-3, IV-4), three males were unaffected (IV-1, IV-5, IV-6) and one female was unaffected (IV-7). IV-3 and IV-4 died because of the severity of this disease. Samples of blood were collected from parents (III-1, III-2), one affected male (IV-2) and one unaffected sibling (IV-1). The affected individual was identified as β -thalassemia major and was six months old.

Family C (Figure 1c) was recruited from Hayatabad Peshawar. Still, the family consisted of four generations comprising three affected females (IV-1, IV-2, IV-3), and parents (III-1, III-2) who were in both paternal and maternal consanguineous loops. IV-2 and IV-3 died because of the severity of the disease. Blood samples were collected from parents (III-1, III-2) and one affected female (IV-1). Parents of the affected individual were suffering from β -thalassemia major. The affected individual was identified as β -thalassemia major at two months.

Family D (Figure 1d) was enrolled in Charsadda, consisting of four generations. The fourth generation comprising of one affected male (IV-1), one affected female (IV-3), one carrier male (IV-2) and one carrier female (IV-4). Samples of blood were collected from parents (III-1, III-2), one female affected (IV-3) and one carrier sibling (IV-2). One of the parents is a thalassemia major, while the other is a carrier of β -thalassemia. The affected individual was identified as β -thalassemia major at three months of age.

Family E (Figure 1e) was recruited from Mardan, and they have resided here for the previous two generations. The family consisted of four generations comprising of one affected male (IV-1) and six unaffected females (IV-2, IV-3, IV-4, IV-5, IV-6, IV-7), and parents (III-1, III-2) who were in the maternal consanguineous loop. Samples of blood were collected from parents (III-1, III-2), one affected female (IV-3) and one normal sibling (IV-3). Parents of the affected individuals were carriers of β -thalassemia. The affected individual was detected as β -thalassemia major at three months of age.

Family F (Figure 1f) was enrolled in Nowshera KP. The family consisted of four generations comprising one affected male (IV-1), one affected female (IV-6), two unaffected males (IV-2, IV-3) and two carrier females (IV-4, IV-5). Parents were in the maternal and paternal consanguineous loop. Samples of blood were collected from parents (III-2, III-3), one affected female (IV-6) and one unaffected sibling (IV-3). Parents of the affected individual were carriers of β -thalassemia. The affected individual was identified as a β -thalassemia major who was 11 months old.

Detailed clinical and laboratory analysis of patients (IV-3, IV-2, IV-1, IV-3, IV-1 and IV-1 of the six families A, B, C, D, E and F, respectively) presents low hemoglobin levels of 7.5 g/dL, low MCH and MCV in their CBC picture. Similarly, their Hb electrophoresis revealed a high percentage of HbF with a very low percentage of HbA. Their peripheral blood smear indicates an iron overload. The affected person's transfusion status is about thrice a month which shows a hyperactive spleen. They present a short musculature with weakness, pale or yellowish skin coloration, facial bone deformities and abdominal swelling due to spleen enlargement. The clinical investigation of affected patients is given in Table 2.

3.2 Mutation analysis

Five β -thalassemia gene variants were investigated in six Pashtun consanguineous families. The ARMS-PCR-based approach was used to screen known β -thalassemia causal mutations. Blood samples were taken from six patients suffering from β -thalassemia, dependent on transfusion and their family members, providing relevant data for molecular study. Amplified ARMS-PCR product was analyzed on 2% polyacrylamide gel, treated with

Family order	Age	Gender	Hb g/dL	MCV fL	MCH Pg	HbA %	HbF %	Mutation type	Clinical report
A	6 Y	M	7.5	71.41	20.14	77.40	20.60	N/A	β-Thalassemia major
B	29 Y	M	9.3	65.30	20.33	58.00	16.70	IVS-1 (G> T)	β-Thalassemia major
C	5 Y	F	6.5	66.58	19.05	67.70	23.48	FR 41-42	β-Thalassemia major
D	4 Y	F	7.5	73.90	18.60	3.70	94.70	FR 8-9 (+G)	β-Thalassemia major
E	23 Y	M	8.4	75.33	21.87	66.90	25.30	IVS1-5 (G> C)	β-Thalassemia major
F	13 Y	F	8.7	68.50	19.09	86.20	10.30	FR 8-9 (+G)	β-Thalassemia major

Table 2.
Different parameters of CBC, Hb electrophoresis and mutation types of all families

Source(s): By authors (Ms Ayesha Ghalib under the supervision of Dr Waleed)

ethidium bromide. Mutation analysis from common five mutations in KP (Fr 8-9(+G), CD 5(-CT), IVS 1-5(G> C), IVS1-1(G> T) and Fr 41-42(-TTCT)) indicated the FR 8-9(+G) as the most prominent homozygous mutation followed by IVS 1-5(G> C). [Figure 2](#) shows typical electrophoresed gels for each mutant allele found.

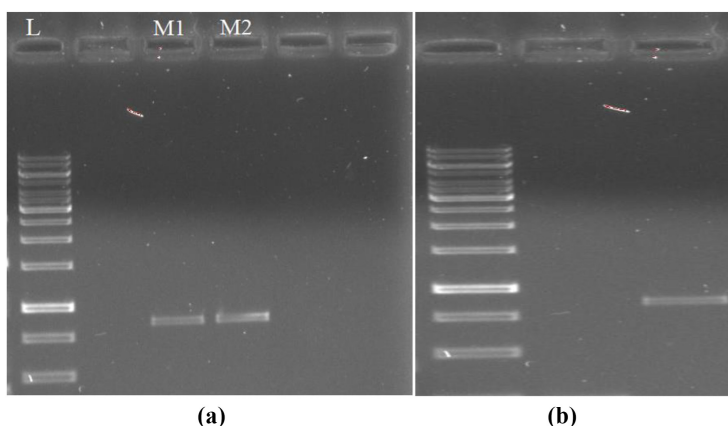

Notes(s): This indicates that both bands are of the same mutation and have the same size (250bp) as compared to the size standard. Subsequently, the IVS1-5 also shows the same pattern on the gel; a product size of 250bp. The primers designed for this study are of the same product sizes, i.e. 250bp

A: Gel electrophoresis of Amplified PCR product of Fr8-9 mutation. “L” represents the 1kb DNA ladder. “M1” indicates Family (D) mutant product, while “M2” shows Family (F) mutant product.

B: Amplified PCR product of IVS 1-5(G > C) mutant gene. “L” indicates the 1kb DNA ladder, and “M” represents the mutant gene product of family B affected individuals

Source(s): By authors (Miss. Ayesha Ghalib under supervision of Dr. Waleed, at Rehman Medical Institute Peshawar)

Figure 2.
The electrophoresis image shows the presence of the same mutant bands (FR8-9) of different families, each band represents the product that is amplified using ARMS PCR by comparing it to the DNA size standard (1 kb)

4. Discussion

β -thalassemia is a common inheritable illness in Pakistan. It results in either faulty or a total lack of hemoglobin β -chain synthesis. Factors including cousin marriages, high birth rates, unavailability of genetic counseling and a lack of prenatal diagnostic tools contribute to the prevalence of β -thalassemia in Pakistan. Moreover, lack of awareness is another burning issue to enhance the number of thalassemia patients in our country. This study was targeted to explore the β -thalassemia mutations in KP Pakistan. IVS-1-5 (G> C), Fr 8/9(+G), Fr41/42 (-TTCT), IVS-1-1 (G> T), IVS-II-1 (G> A), CAP+1, Cd 5 (-CT), Cd 16 and Cd 15 (G> A) (29) are reported among the regionally prominent mutations. In this study, out of six unrelated transfusion-dependent patients, two patients carried FR 8-9 (+G), which is the most frequent mutation, and three of the patients were identified as IVS 1-5 (G> C), IVS-1 (G> T) and FR 41-42, respectively. This study highlights that FR 8-9 (+G) is the common β -globin gene mutation that underlies β -thalassemia in KP.

Another study was conducted on the molecular epidemiology of β -thalassemia gene mutation found in several tribal groups residing in Pakistan. Multiplex ARMS-PCR was used to evaluate 648 samples altogether, and (IVS 1-5, Fr 8-9, Fr 41-42, Deletion 619bp, Cd-30, Cd-15, Cd-5 and IVS 1-1) were the most common identified mutations. The findings indicate that 76.9% of Balochis and around 20% of Punjabis have the IVS 1-5 mutation. Fr 8-9, seen in around 31.3% of Pashtuns and 47% of Saraikies, is the second most common mutation (Ansari *et al.*, 2011).

Jalil *et al.* conducted a study in 2019 on mutation analysis of β -thalassemia by multiplex ARMS-PCR in KP Pakistan. A total of 60 β -thalassemia major patients were analyzed by multiplex ARMS, which reveals that FR 8-9 (+G) is the most prominent mutation that accounts for 20% of the population (Jalil *et al.*, 2019). In 2012, another study was conducted on the incidence of different mutations in β -thalassemia and their relationship to hematological parameters. This study enlisted the participation of 515 people. ARMS-PCR was used to look for mutations in the β -gene. IVS 1-5 were found in 24.5% of patients, Fr 41-42 in 14.8% and Fr 8-9 in 35.5% of patients, according to the study's findings. The results show that Fr 8-9 has the lowest cell indices and is the most prevalent thalassemia mutation (Khattak, Ahmed, Anwar, Ali, & Shaikh, 2012).

For the Pakistani population, the most common β -thalassemia mutations were IVS 1-5 (G> C) (36.48%), Fr 8-9 (+G) (31.16%), Fr 41-42 (-TTCT) (7.11%), etc. This study's results were consistent with that of the above discussed as it shows that IVS 1-5 (G> C) is ranked as the second most frequent mutation, and Fr 8-9 (+G) is the most common one (Black *et al.*, 2010).

5. Conclusion

This mutational investigation reveals that the most common mutation in this population of KP province is Fr 8-9 (+G), followed by IVS 1-5 (G> C). Multiplex ARMS-PCR, an economical method, can be efficiently used for mutational analysis. To mitigate the impact of disease, the study recommends government intervention such as providing prenatal diagnostic services, widespread screening, genetic counseling and cost-effective screening options in this population to control the disease burden. Additionally, it is suggested that these measures should be implemented before marriage for the best results.

References

- Ahmed, S., Saleem, M., Modell, B., & Petrou, M. (2002). Screening extended families for genetic hemoglobin disorders in Pakistan. *New England Journal of Medicine*, 347(15), 1162-1168.
- Ansari, S. H., Shamsi, T. S., Bohray, M., Khan, M. T., Farzana, T., Perveen, K., & Erum, S. (2011). Molecular epidemiology of β -thalassemia in Pakistan: Far reaching implications. *118*(21), 5309.

-
- Black, M. L., Sinha, S., Agarwal, S., Colah, R., Das, R., Bellgard, M., & Bittles, A. H. (2010). A descriptive profile of β -thalassaemia mutations in India, Pakistan and Sri Lanka. *Journal of Community Genetics*, 1(3), 149–157.
- Cao, A., & Galanello, R. (2010). Beta-thalassaemia. *Genetics in Medicine*, 12(2), 61–76.
- Hafeez, M., Aslam, M., Ali, A., Rashid, Y., & Jafri, H. (2007). Regional and ethnic distribution of beta thalassaemia mutations and effect of consanguinity in patients referred for prenatal diagnosis. *Journal of the College of Physicians and Surgeons–Pakistan: JCPSP*, 17(3), 144–147.
- Higgs, D. R., Engel, J. D., & Stamatoyannopoulos, G. (2012). Thalassaemia. *The Lancet*, 379(9813), 373–383.
- Jalil, T., Yousafzai, Y. M., Rashid, I., Ahmed, S., Ali, A., Fatima, S., & Ahmed, J. (2019). Mutational analysis of beta thalassaemia by multiplex ARMS-PCR in Khyber Pakhtunkhwa, Pakistan. *Journal of Ayub Medical College Abbottabad*, 31(1), 98–103.
- Khattak, S. A. K., Ahmed, S., Anwar, J., Ali, N., & Shaikh, K. H. (2012). Prevalence of various mutations in beta thalassaemia and its association with haematological parameters. *JPMA-journal of the Pakistan Medical Association*, 62(1), 40.
- Pervaiz, R., Faisal, F., & Serakinci, N. (2018). Practice of consanguinity and attitudes towards risk in the Pashtun population of khyber pakhtunkhwa, Pakistan. *Journal of Biosocial Science*, 50(3), 414–420.
- Rachmilewitz, E. A., & Giardina, P. J. (2011). How I treat thalassaemia. *Blood, The Journal of the American Society of Hematology*, 118(13), 3479–3488.
- Traeger-Synodinos, J., & Harteveld, C. L. (2014). Advances in technologies for screening and diagnosis of hemoglobinopathies. *Biomarkers in Medicine*, 8(1), 119–131.
- Weatherall, D. J., & Clegg, J. B. (2001). *Distribution and population genetics of the thalassaemias. The Thalassaemia Syndromes* (4th ed., pp. 237–84). Oxford: Blackwell Publishing.

Corresponding author

Ruqiya Pervaiz can be contacted at: ruqiyapervaiz@gmail.com

For instructions on how to order reprints of this article, please visit our website:

www.emeraldgrouppublishing.com/licensing/reprints.htm

Or contact us for further details: permissions@emeraldinsight.com