

Mapping Market-Based Accounting Research in Indonesia: Graphics and Guidelines for Future Research

Novrys Suhardianto*, Bambang Subroto**, Grahita Chandrarin***

*Universitas Airlangga, City University of Hong Kong, **Brawijaya University, ***Merdeka University of Malang

ARTICLE INFO

Article history:

Received 31 August 2016
Accepted 28 February 2017
Available online 31 May 2017

Keywords:

Market Based Accounting
Research Descriptive
Research Map

ABSTRACT

The purpose of this study is to describe the development of market based accounting research (MBAR) published in Indonesia for 10 years. This study attempts to explain the topics of MBAR, research method used, the variables, between-variable relationship formed, and the units analysis used in MBAR. This research uses qualitative-descriptive method to create descriptive models of MBAR articles published in accounting journals that have been accredited with minimum grade of B. The analysis of 109 MBAR articles of five accounting journals shows that 10 MBAR themes are still potential. Among three methods in MBAR, the multivariate association study is dominant. Some papers use intervening and moderating model to explore the relationship between accounting data and capital market reaction. The results for each theme are described in a research map that shows the relationship between variables (constructs) of MBAR from three units of analysis. This paper finds some implications to MBAR research agenda in the future, especially for meta-analysis research and triangulation research, due to many inconsistencies of the MBAR findings in Indonesia. In addition, accounting standard research topic is still promising in the moment of accounting standards transition.

1. Introduction

Lev and Ohlson (1982) and Meek and Thomas (2004) express the notion of capital market based accounting research (MBAR) to find the relationship between published accounting information with the consequences of the use of such information that is reflected in the characteristics of securities traded in capital markets. MBAR is considered as a popular topic because various MBAR papers presented at the *Simposium Nasional Akuntansi* or SNA (Indonesian Accounting Symposium) as well as published in Accounting Review journal. Table 1 presents the number of MBAR articles presented in SNA and Accounting Review.

MBAR generally tests the decision of accounting information (see Scott, 2006, 122-148). In Indonesia, accounting research that aims to map the development MBAR is not too popular. Mapping research is descriptive research that transfers data into more meaningful format, indicates areas that need further study, provides a basis for discussions that produce a common understanding about a problem, and produce a model that represents a descriptive structure of MBAR development (Abdel-Khalik and Ajinkya, 1979, 21-23; Kothari, 1990, 2-3; Meyer and Rigsby, 2001).

This study aims to describe the development of MBAR in Indonesia for a decade. To achieve these objectives, the study seeks to generate graphical models that represent (1) the description of the themes examined by MBAR; (2) the description of the variables involved in MBAR; (3) the description of the research methods used; and (4) the description of the relationship between variables formed. The study reviews the development of MBAR in Indonesia and identifies research topics that need further investigation.

This research contributes to the development of MBAR in Indonesia by providing pedagogically valuable document as defined by Kothari (2001) which helps MBAR researchers to avoid reinventing the wheel. Descriptive research is very important to evaluate the development of a particular topic, highlight the theory, and criticize the empirical findings (for example see Brown et al., 1987; Brown et al., 2007; Cho and Jung, 1991; Healy and Palepu, 2001; Heck and Bremser, 1986; Simon, 2007). These research is useful for meta-analysis study that synthesize the results of relevant research to produce a conclusion about a body of research (Cooper, 2010, 6-7).

Table 1. MBAR Paper in SNA (National Accounting Symposium) & Accounting Review (AR)

Year	SNA			AR		
	MBAR paper	Total paper	%	MBAR paper	Total paper	%
2000	15	41	37%	3	68%	16%
2001	18	52	35%	6	58%	21%
2002	10	53	19%	8	43%	17%
2003	18	91	20%	14	45%	34%
2004	18	76	24%	11	55%	24%
2005	9	69	13%	13	54%	28%
2006	12	84	14%	12	46%	28%
2007	3	80	4%	9	25%	20%
2008	9	78	12%	10	41%	19%
2009	9	64	14%	14	39%	20%
Total	130	722	18%	100	46%	23%

2. Literature Review

The development of MBAR since the 1970s to the 1990s is well described by Lev and Ohlson (1982), Kothari (2001), Beaver (1982, 1996, 2002), and Dumontier and Raffournier (2002). There are 10 topics of MBAR found in previous studies. Accounting information content, discretionary behavior, market efficiency, and value relevance have been reviewed by more than one study. Table 2 presents the list of these themes.

Table 2. The Division of MBAR Theme by Previous Researchers

No	Theme	Researcher
1.	The consequences of Accounting Standards	Lev & Ohlson (1982)
2.	The consequences of Performance Measure Alternatives	Kothari (2001)
3.	The consequences of Accounting Disclosure	Dumontier & Raffournier (2002)
4.	Accounting Value Information Content	Lev & Ohlson (1982); Dumontier & Raffournier (2002); Kothari (2001)
5.	Analyst Behavior	Beaver (2002)
6.	Discretionary Behavior	Lev & Ohlson (1982); Kothari (2001); Beaver (2002)
7.	Valuation and Fundamental Analysis	Kothari (2001)
8.	Market Efficiency	Lev & Ohlson (1982); Kothari (2001); Beaver (2002)
9.	Value Relevance	Kothari (2001); Beaver (2002)
10.	Earning Response Coefficient/ ERC	Kothari (2001)

To test the 'relationship' between the accounting information published and the value of shares in the capital market, MBAR uses 2 methods i.e. event studies and association studies (Kothari, 2001). Through the event study, researchers will be able to conclude whether an event brings new information to market participants (Kothari, 2001) in timely basis. Specifically, if the returns before the event are different from the returns after or if the return in an event windows different with its average, the event has information content to investors (Tandelilin, 2010, 572-576). Event study is also used to test the efficiency of capital market (Hartono, 2008, 529-534).

On the other hand, association study provides evidence about the role of accounting data as a summary of events affecting the value of companies during the reporting period (Brown et al., 1999; Dumontier and Raffournier, 2002). Association study does not conclude a causal relationship between accounting data and value stocks because accounting reports are not the only source of information (Kothari 2001). The strength of association between accounting information and price/return ordinary shares can be measured by R^2 (Brown et al., 1999; Dumontier and Raffournier, 2002). Low association ($R^2 \approx 0$) means stock prices cannot be estimated using accounting data. High association ($R^2 \approx 1$) means that accounting data could be the estimator of stock price. These two methods will be used in descriptive modeling research framework (Figure 4) to describe the development of MBAR method in Indonesia.

According to definition of MBAR expressed by Lev and Ohlson (1982) and Meek and Thomas (2004), MBAR dependent variable should reflect investor reaction such as stock return and trading volume of shares (Deegan, 2000, 360; Beaver, 1968; Karpoff, 1986; Jang and Ro, 1989). Brown (1994, 27) states that the dependent variable of MBAR must reflect market behavior. In addition to returns and volume, there are some proxies of market behavior such as frequency of trading, bid-ask spread, or market depth. The independent variables of MBAR are any accounting information (events) that could change market expectations and reactions. MBAR does not search the relevance of any information other than accounting. The use of moderating and intervening variable in MBAR is not common. There were no published MBAR papers in JRAI

(jurnal riset akuntansi Indonesia/ the Indonesian journal of accounting research) from 2000 to 2009 that stated using moderating and intervening variable in their title.

Luft and Shields (2003) have presented 6 models of inter-variable relationship that can be used by MBAR and represented descriptive structure of inter-variable relationship. These models are presented in figure 1.

Figure 1. Inter-Variable Relationship Model

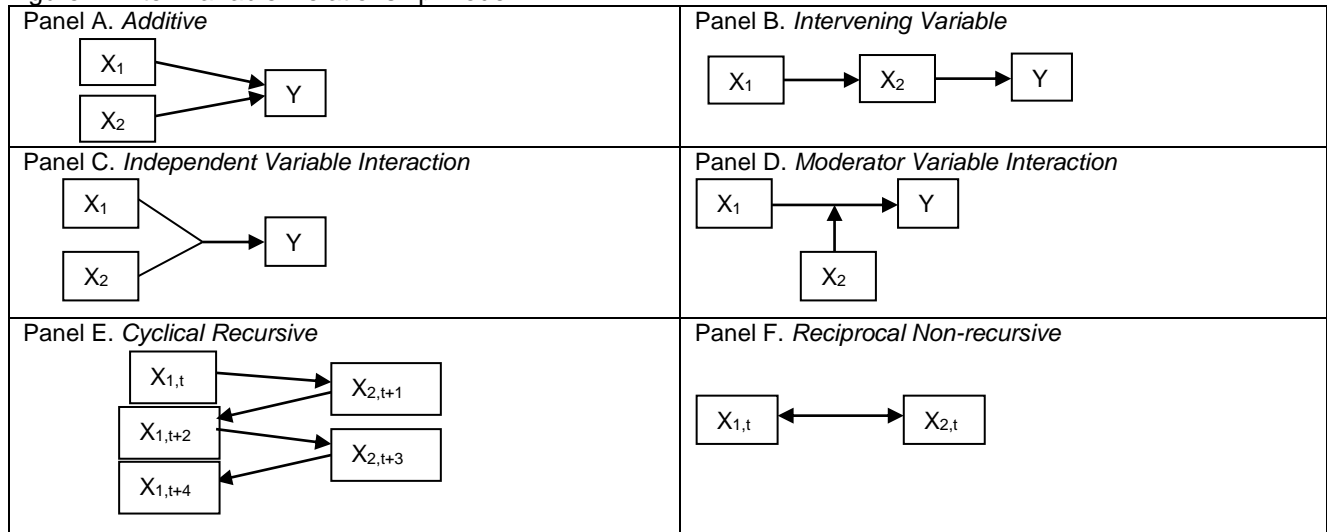

Source: Luft and Shields (2003)

There are 2 models that may be added since MBAR often use time series data i.e. distributed lag model and *autoregressive* model (Gujarati and Porter, 2009, 617). The two models are used because the independent variables have time lag in influencing the dependent variables.

Figure 2. Distributed-Lag and Autoregressive Model

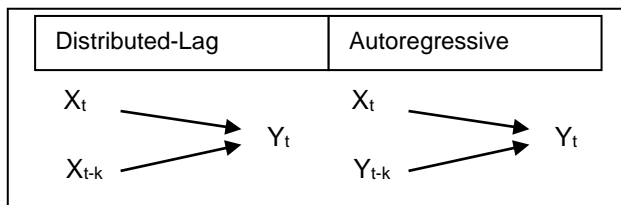

Source: Gujarati (2009: 617)

Luft and Shields (2003) divide the unit of analysis of accounting research into four categories. They are individual, organization subunit, organization, and beyond organization. MBAR usually uses organization as the unit of analysis. However, some of MBAR analyze market condition or macro-economic factors that is beyond organization.

One excellent review in accounting research is Luft and Shields (2003). Luft and Shields (2003) provide a guidance in reviewing the development of accounting research; include (1) identifying the themes and variables, (2) identifying the inter-variables relationship, (3) identifying the unit of analysis, and (4) establishing the mapping guidance. This paper borrows Luft and Shields' conceptual framework to mapping the development of MBAR in Indonesia. Moreover, this paper also develops its framework based on Lev and Ohlson (1982), Kothari (2001), Beaver (2002), and Dumontier and Raffournier (2002).

The framework of this research is shown in figure 3. This framework shows the gap of MBAR review in Indonesia. In mapping MBAR, this research uses Luft and Shields's framework that equipped with MBAR normative theory. The focuses of this research are to identify (i) MBAR themes, (ii) MBAR variables, (iii) relationship between variables, (iv) methods utilized, and (v) MBAR unit of analysis.

Figure 3. Research Framework

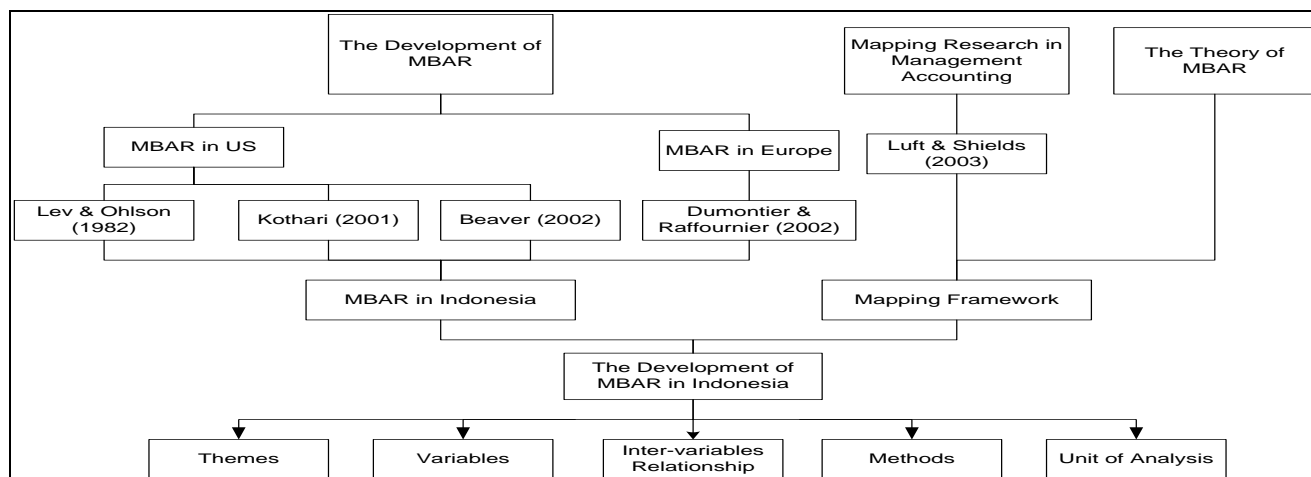

3. Research Methods

The framework developed in the literature review is used to describe the MBAR characteristics and offers ideas about future MBAR opportunities (the importance of research framework discussed in Sekaran, 2003, 122; Indriantoro and Supomo, 2002, 88). This study reviews MBAR articles published in Indonesia from 2000 until 2009. This research assumes that 10 years observations will be able to capture the development states of MBAR.

The subject of this research is MBAR papers that published in accredited accounting journals in Indonesia that satisfy two criteria. First, the journals should have B accreditation grade until 2010. This is important to control the quality of the MBAR articles. Second, the journals should publish accounting research articles only. A journal that publishes broad topics such as economics, management, and accounting might disproportionate the accounting topics.

This study uses Creswell’s (2007, 150-155) recommendation to analyze qualitative data. The steps of analyzing the MBAR articles are (1) developing database; (2) sorting the data; (3) analyzing descriptive statistics, to find market share of MBAR, journal share, and the profile of research model; (4) analyzing the content of MBAR publications, to identify the themes of MBAR, the variables researched, the relationship between variables, the methods utilized, the unit analysis used, the summary, limitation, and future research chance; and (5) describing the data using text, table, or chart.

This research uses descriptive framework of Luft and Shields (2003) to describe the development of MBAR. This research will describe the development of MBAR in the sense of its topics, variables, inter-relationship of variables, methods, and the unit of analysis. This framework is used to discuss the findings of this paper (See figure 4.)

Figure 4. Descriptive Modeling Framework

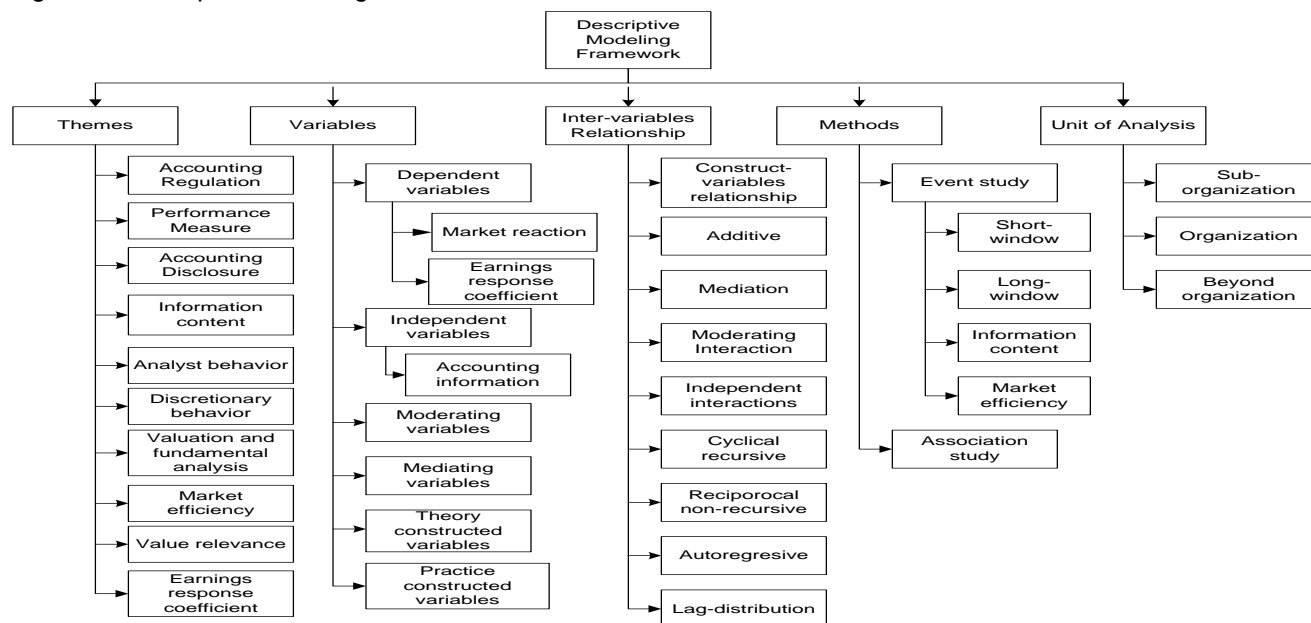

4. Results and Discussion

This study finds 5 out of 22 accounting journals that satisfy the criteria. The journals are Jurnal Riset Akuntansi Indonesia (JRAI) published by Indonesian Institute of Accountant and the office in Universitas Gadjah Mada, Jogjakarta; Jurnal Akuntansi dan Keuangan Indonesia (JAKI) published by Universitas Indonesia, Jakarta; Jurnal Akuntansi (JA) published by Universitas Tarumanegara (UNTAR), Jakarta; Akuntabilitas (AK) published by Universitas Pancasila, Jakarta; and Jurnal Akuntansi dan Auditing Indonesia (JAAI) published by Universitas Islam Indonesia (UII), Jogjakarta. The list of these journals is shown in table 3.

Table 3. List of Accounting Journals

Panel A: Indonesia Accounting Journals			
No	Name	ISSN	Description
1	Jurnal Akuntansi Dan Auditing Indonesia (JAAI)	1410-2420	Match the criteria
2	Jurnal Akuntansi (JA)	1410-3591	Match the criteria
3	Jurnal Riset Akuntansi Indonesia (JRAI)	1410-6817	Match the criteria
4	Akuntabilitas (AK)	1412-0240	Match the criteria
5	Jurnal Akuntansi Dan Keuangan Indonesia (JAKI)	1829-8494	Match the criteria
6	Media Riset Akuntansi, Auditing Informasi	1411-8831	Not match the criteria
7	Jurnal Akuntansi & Investasi	1411-6227	Not match the criteria
8	Jurnal Akuntansi & Bisnis: Journal of Accounting & Business	1412-0852	Not match the criteria
9	Jurnal Akuntansi Dan Keuangan	1411-0288	Not match the criteria
10	Jurnal Riset Akuntansi, Manajemen, Ekonomi	1411-8572	Not match the criteria
11	Jurnal Akuntansi & Manajemen	0853-1269	Not match the criteria
12	Kompak Jurnal Akuntansi, Manajemen Dan Sistem Informasi	0854-6142	Not match the criteria
13	Wahana: Jurnal Ekonomi, Manajemen Dan Akuntansi	1410-8224	Not match the criteria
14	Jurnal Bisnis Dan Akuntansi	1410-9875	Not match the criteria
15	Forum Ekonomi: Jurnal Ekonomi, Manajemen Dan Akuntansi	1411-1713	Not match the criteria
16	Akuntansi Dan Keuangan Sektor Publik	1411-5921	Not match the criteria
17	Jurnal Akuntansi Dan Keuangan	1411-6510	Not match the criteria
18	Tema: Telaah Ekonomi, Manajemen, Dan Akuntansi	1411-8149	Not match the criteria
19	Jurnal Widyia Manajemen & Akuntansi	1411-8599	Not match the criteria
20	MAKSI: Jurnal Manajemen, Akuntansi & Sistem Informasi	1412-6680	Not match the criteria
21	Jurnal Manajemen, Akuntansi Dan Bisnis	1693-252x	Not match the criteria
22	JABM: Jurnal Akuntansi - Bisnis & Manajemen	0854-4190	Not match the criteria

Panel B: Publications of Five Selected Journals

Year	JRAI	JAKI	JA	AK	JAAI
2000	Vol. 3 No. 1-2	-	NA	-	Vol.4 No.1-2
2001	Vol. 4 No.1-3	-	NA	Vol.1 No.1-2	Vol.5 No.1-2
2002	Vol. 5 No.1-3	-	Vol.6 No.1-2	Vol.2 No.1-2	Vol.6 No.1-2
2003	Vol. 6 No.1-3	-	NA	Vol.3 No.1-2	Vol.7 No.1-2
2004	Vol. 7 No.1-3	Vol.1 No.1-2	Vol.8 No.1-2	Vol.4 No.1-2	Vol.8 No.1-2
2005	Vol. 8 No.1-3	Vol.2 No.1-2	Vol.9 No.1-3	Vol.5 No.1-2	Vol.9 No.1-2
2006	Vol. 9 No.1-3	Vol.3 No.1-2	Vol.10 No.1-3	Vol.6 No.1-2	Vol.10 No.1-2
2007	Vol. 10 No.1-3	Vol.4 No.1-2	Vol.11 No.1-3	Vol.7 No.1-2	Vol.11 No.1-2
2008	Vol. 11 No.1-3	Vol.5 No.1-2	Vol.12 No.1-3	Vol.8 No.1-2	Vol.12 No.1-2
2009	Vol. 12 No.1-3	Vol.6 No.1	Vol.13 No.1-3	Vol.9 No.1	Vol.13 No.1-2

JRAI and JAAI provide complete publication to be analyzed however; JA is missed for three years publication. The total article published in the five accounting journals is 653 articles and MBAR takes 16.48% from total articles.

Table 4. MBAR Articles Compare to Others

Category	JRAI	JAKI	JA	AK	JAAI	Total
MBAR	49	15	19	15	11	109
FACM*	59	22	34	36	36	187
Others	72	31	112	73	69	357
Total	180	68	165	124	116	653

*FACM: financial accounting and capital market, a broader topic than MBAR.

4.1. Descriptive statistics of MBAR publication

Market share of MBAR is the percentage of MBAR articles that are published in a particular accounting journal (Hesford et al., 2007). MBAR is published in JRAI for 27.3% and 21.8% in JAKI. These two journals are leading in MBAR publication. Table 5 shows the trend of market share and journal share of MBAR.

Table 5. Market Share and Journal Share of MBAR

Panel A Market Share of MBAR					
Market Share = $(\sum \text{MBAR articles in journal } i) \div (\text{Total article of journal } i)$					
Year	JRAI	JAKI	JA	AK	JAAI
2000	35.7%	–	NA	–	10.0%
2001	15.0%	–	NA	0.0%	10.0%
2002	19.0%	–	6.3%	0.0%	0.0%
2003	42.1%	–	NA	16.7%	9.1%
2004	45.0%	0.0%	0.0%	25.0%	25.0%
2005	38.9%	30.8%	10.7%	18.2%	16.7%
2006	16.7%	25.0%	16.0%	15.8%	16.7%
2007	16.7%	25.0%	16.0%	15.0%	25.0%
2008	17.6%	33.3%	11.1%	12.5%	0.0%
2009	26.7%	16.7%	13.3%	0.0%	0.0%
Average	27.3%	21.8%	10.5%	11.5%	11.2%
Panel B Journal Share of MBAR					
Journal Share = $(\sum \text{MBAR articles in } i \text{ journal}) \div (\text{Total MBAR article in all journal})$					
Year	JRAI	JAKI	JA	AK	JAAI
2000	83.3%	–	NA	–	16.7%
2001	75.0%	–	NA	0.0%	25.0%
2002	80.0%	–	20.0%	0.0%	0.0%
2003	72.7%	–	NA	18.2%	9.1%
2004	60.0%	0.0%	0.0%	20.0%	20.0%
2005	38.9%	22.2%	16.7%	11.1%	11.1%
2006	20.0%	20.0%	26.7%	20.0%	13.3%
2007	18.8%	18.8%	25.0%	18.8%	18.8%
2008	25.0%	33.3%	25.0%	16.7%	0.0%
2009	44.4%	11.1%	44.4%	0.0%	0.0%
Average	51.8%	17.6%	22.5%	11.6%	11.4%

Journal share describes the total MBAR articles that published in a certain journal compare to all MBAR articles in all journals (Hesford et al., 2007). On average, JRAI contributes 51,8% of published MBAR articles in a decade. Though first published in 2004, JAKI provides 17.6% of MBAR articles.

Value relevance study gets the biggest portion (43.12%) of MBAR topics. Information content study had 15.60% portion from 109 MBAR articles and all journals have publication in this theme.

Table 6. The Themes of MBAR in Indonesia

Themes	The Amount of Articles						Total	Portion
	JRAI	JAKI	JA	AK	JAAI			
Analyst Behavior	–	–	–	–	–	0	0.00%	
Valuation and Fundamental Analysis	1	–	–	–	–	1	0.92%	
The consequences of Accounting Standards	2	–	–	–	–	2	1.83%	
Market Efficiency	2	–	–	–	1	3	2.75%	
The consequences of Performance Measure Alternatives	–	1	2	1	–	4	3.67%	
The consequences of Accounting Disclosure	–	5	3	–	–	8	7.34%	
Discretionary Behavior	8	2	–	2	1	13	11.93%	
Earnings Response Coefficient	10	–	1	2	1	14	12.84%	
Accounting Value Information Content	6	2	2	4	3	17	15.60%	
Value Relevance	20	5	11	6	5	47	43.12%	
Total	49	15	19	15	11	109		

ERC and discretionary behavior take the third and fourth position. The less researched themes are accounting disclosure consequences, consequences of performance measure, market efficiency, and accounting regulation consequences. The theme that never been researched in Indonesia is the market reaction toward analyst's forecasts because analyst forecast reports are not publicly available in Indonesia capital market.

4.2. Method and Inter-variable relationship

The result indicates that an article may use more than one research model and method. According to table 7, additive model is the most frequently used by researcher (panel A) and therefore, unidirectional and linear model become the most popular model (panel B). Moreover, MBAR that employs additive model and unidirectional (whether linear or not) is classified as association research (panel C). The result also shows that nonlinear relationship between accounting data with market reaction is unpopular (4 from 109 papers). The second popular model is construct-variable (panel A) that is used by event study and difference study (panel C). The third and fourth popular models are moderator variable interaction (panel A) and intervening model.

Table 7. MBAR Model and Method

Description	Frequency					Total
	JRAI	JAKI	JA	AK	JAAI	
<i>Panel A: Research Model</i>						
Additive (Add)	25	12	15	10	5	67
Intervening Variable (IV)	–	–	1	–	–	1
Independent Variable Interaction (IVI)	1	–	–	–	–	1
Moderator Variable Interaction (MVI)	11	3	2	–	1	17
Cyclical Recursive	–	–	–	–	–	–
Reciprocal Non-recursive	–	–	–	–	–	–
Distributed-Lag	–	–	–	–	–	–
Autoregressive	–	–	–	–	–	–
Construct-Variable relationship	17	3	3	5	5	33
<i>Panel B: Classification of Model</i>						
Unidirectional	37	15	18	10	6	86
Bidirectional	–	–	–	–	–	–
Linear	35	15	18	10	4	82
Curvilinear (Nonlinear)	2	–	–	–	2	4
Ordinal (monotonic)	12	3	2	–	1	18
Dis-ordinal (non-monotonic)	–	–	–	–	–	–
Construct-Variable relationship	17	3	3	5	5	33
<i>Panel C: Research Method</i>						
Association Study	37	14	18	10	6	85
Event Study	12	3	3	5	4	27
Difference Study	5	1	1	2	1	10

The theme of MBAR used in various research models are ERC and the discretionary behavior. On the other hand, market efficiency testing and information content study use only event study or difference study and the use of association study by these themes generally for additional analysis only. The other themes use various research methods. An article in valuation and fundamental analysis uses additive model with associative method. Such model and method are also used by performance measure alternative research. Research in consequences of accounting disclosure generally employs additive model (associative method) or construct-variable relationship (difference study). The last theme, consequences of accounting regulation, generally uses additive model, moderator interaction, and construct-variable relationship.

Table 8. The Using of Research Model and MBAR Themes

Research Model \ MBAR Themes	Research Model												
	Additive	Intervening variable	Independent var. Interaction	Moderating var. interaction	Construct-vari. relationship	Unidirectional	Linear	Nonlinear	Monotonic	Construct-vari. relationship	Association study	Event study	Difference study
Analyst Behavior	–	–	–	–	–	–	–	–	–	–	–	–	–
Valuation and Fundamental Analysis	1	–	–	–	–	1	1	–	–	–	1	–	–
The consequences of Accounting Standards	2	–	–	3	1	2	2	–	–	1	2	1	–
Market Efficiency	–	–	–	–	3	–	–	–	–	3	–	3	–
The consequences of Performance Measure Alternatives	4	–	–	–	–	4	4	–	–	–	4	–	–
The consequences of Accounting Disclosure	5	–	–	–	2	8	8	–	3	2	8	2	–
Discretionary Behavior	6	–	–	2	6	8	8	–	2	6	7	3	4
Earnings Response Coefficient	6	–	1	6	2	13	13	–	7	2	13	1	1
Accounting Value Information Content	3	–	–	–	17	3	3	–	–	17	3	17	3
Value Relevance	40	1	–	6	2	47	43	4	6	2	47	27	2
Total	67	1	1	17	33	86	82	4	18	33	85	27	10

4.3. The development of MBAR

The next analysis emphasizes on qualitative aspect of MBAR development by drawing it into a research map. The map describes the variables researched, inter-variable relationship, and the unit of analysis. The map and its legend are presented in the appendix.

4.3.1. Analyst behavior

An analyst behavior research describes market consequences of analysts forecast publication. However, this research topic is not found because analyst forecast reports are not available for public. Therefore, regulatory body in Indonesia should consider that analyst forecast is to become one of the public information sources to make investment decision.

4.3.2. Valuation and fundamental analysis

Kothari (2001) describes that valuation and fundamental analysis aims to find out a company's valuation model that can reliably predict market value of shares. For a decade in Indonesia, only Wirama (2009) who studied the ability of Feltham and Ohlson (1995) valuation model in predicting market value of shares. However, many valuation models have not been researched yet such as dividend-discounting model or balance sheet model. (See appendix 2)

4.3.3. Accounting regulation consequences

Lev and Ohlson (1982) have described the development of research in consequences of accounting regulation in term of market reaction. There are 2 articles on this theme i.e. Alim and Hartini (2001) and Lestari and Baridwan (2008). They investigate the consequences of tax regulation changing and accounting policy difference, respectively. In Indonesia from 2000 to 2009, the global adoption IFRS has not been researched yet although it brings economic consequences (see for example Daske et al., 2008; Jeanjean and Stolowy, 2008). (See appendix 3)

4.3.4. Market efficiency

Three articles showed that Indonesia has a semi-strong capital market because it only reacts to existing information in capital market (Setiawan and Subekti, 2005; Marfuah, 2006). In term of decision-making, many investors react improperly to the growth of a company. Researchers conclude that Indonesian investors are more focus on potential cash information rather than financial statement indicators. However, the three researchers used the same model to test the efficiency market by using dividend announcement. Thus, many publications other than dividend have not been researched. (See appendix 4)

4.3.5. Performance measure alternative

Research in performance measure alternatives aims to identify the relationship between the uses of certain performance measured by the value of shares. The main conclusion of research in Indonesia is that EVA is still relevant to be used to predict the firm's value of shares although the result was not consistent. Other performance measures such as for banking, insurance, or mining that has special features remain to be potential research area. (See appendix 5)

4.3.6. Accounting disclosure consequences

Accounting disclosure consequences describes the relationship between accounting disclosure with the value of shares. Generally, the relationship between them in Indonesia was not conclusive. Besides accounting disclosure, many specific disclosures such as corporate governance or corporate social responsibility might influence investor decision making but have not been consistently proven. (See appendix 6)

4.3.7. Discretionary behavior

This theme focuses on the market reaction to discretionary behavior of management. In Indonesia, this research starts from the testing of differences in market reaction to financial statement containing earnings management. However, the results showed that earnings management inconsistently influenced market reaction. Researchers usually speculate on the reason of this inconsistency without giving more evidence. Therefore, motivation of earnings management, namely opportunistic and efficiency, needs to be elaborated in the future by using more sophisticated method.

The next step of discretionary research is to observe earnings management in the IPO session since there is a suspicion opportunistic behavior to get high initial price during the offering. Researchers found that listed companies did earnings management during the IPO although there was no consistent evidence of the ability of earnings management in influencing share price after IPO in the secondary market. (See appendix 7)

4.3.8. Earnings response coefficient (ERC)

ERC research in Indonesia is growing along the observation period. Kothari (2001) said that ERC researchers could only compare the significance of ERC with the response coefficient of other variables such as cash flow response coefficient. However, ERC in Indonesia runs more than Kothari (2001) expectation.

The explanatory variable of ERC is increasing such as foreign currency gain/loss, negative income, earnings surprise, auditor, and cash flow. Researchers usually use these variables as the moderator between unexpected earnings (UE) and cumulative abnormal return (CAR). In other words, these variables are used to test the responsiveness of CAR when there is an UE and other moderator variables. (See appendix 8)

4.3.9. Accounting information content

Accounting information content (AIC) can be called as announcement type research (Lev and Ohlson, 1982) because it seeks to find out the market reaction to the accounting publication/event using event study or difference study. The result shows that 17 articles of AIC use various publications such as earnings announcement, dividend, bonus share, bonds rating, right issue, and stock split. Earnings and dividend are still interesting for the market players although corporate action publication leads inconsistent reaction from market players.

AIC research remains interesting topic in the future because many questions have not been answered. Inter-industry information transfer could be potential topic to be further investigated since there was only one article discussed it about. Moreover, AIC research is facing a problem of the independency of price reaction with volume reaction although they come from the same market player. The date of earnings announcement in Indonesia still becomes classical problem because there is no such announcement in Indonesia unless for the companies that listed in cross-border stock exchange. Generally, researchers use the former of the date of financial statements submitting to the stock exchange, submitting it to SEC, or announcing it in mass media as the proxy of announcement date. Only some of MBAR researchers pay more attention to the direction of capital market reaction. Most of them focus on the existence of market reaction without considering the direction of the reaction. (See appendix 9)

4.3.10. Value relevance study

Value relevance study investigates the correlation of accounting data with stock price or its liquidity (Holthausen and Watts, 2001). Generally, the result of value relevance study indicates whether accounting value can predict stock price or not.

The consistency of prediction power of accounting value remains a questionable fact. Nonlinear model of relationship between accounting data and stock prices could not explain such inconsistency (Soepratikno and Hartono, 2005; Rahmawati, 2005, 2006; Sumarni and Rahmawati, 2007). Therefore, meta analysis is needed to indicate the best predictor of stock prices.

Although value relevance study is the most popular topic in MBAR, it has some weaknesses. Although the articles of value relevance study were published in accredited accounting journal, they used too small sample in utilizing parametric statistics. Other articles were not published in complete and standardized format. Moreover, an article was published twice in two different journals. This indicates the weaknesses of journal management and its review process. A common mistake of value relevance researchers is that they did not report the value relevance study, rather they found the best predictor of stock price and did not examine the causal relationship of accounting data and stock prices. (See appendix 10)

5. Conclusion

This research aims to describe the development of MBAR in Indonesia. The description is drawn on a research map that contains the theme of MBAR, variables, inter-variable relationship, methods, and unit of analysis MBAR. There are nine maps which represent the development of MBAR and contain 18 dependent variables, 154 independent variables, 19 moderating variables, 1 mediating variable, 34 constructs, 5 research models representing 3 research methods, and 3 unit of analysis. The analysis indicates that many MBAR areas are interesting to be investigated in the future. MBAR will be a more important research since the convergence process of international accounting standard is ongoing in 2012. Moreover, meta analysis is needed to synthesize the inconsistency results of MBAR.

However, this study contains some weaknesses. This paper only observes 10 years development while many previous researches make a review for at least 20 years. Due to the data limitation, this paper could

review only a decade of Indonesia accounting research publication that historically starts in the late 90's. Since this study use descriptive approach for broad research area, the analysis is broad but not deep. Therefore, future research should deeply elaborate each theme mapped in this research.

References

- Abdel-khalik, R. and B. Ajinkya., 1979. *Empirical Research in Accounting A Methodological Viewpoint*. USA: American Accounting Association.
- Alim, M. N. and Hartini., 2001. "Implementasi Undang-Undang Perpajakan Tahun 1994 dan Implikasinya terhadap Perilaku Harga Saham." *Jurnal Riset Akuntansi Indonesia* 4(2), 223-234.
- Beaver, W. H. 1968. The Information Content of Annual Earnings Announcements. *Journal of Accounting Research* 6(Supplement), 67-92.
- _____, 1982. Discussion of Market-Based Empirical Research in Accounting: A Review, Interpretation, and Extension. *Journal of Accounting Research* 20(Supplement), 323-331
- _____, 1996. Directions in Accounting Research: NEAR and FAR. *Accounting Horizons* 10(2), 113-124
- _____, 2002. Perspectives on Recent Capital Market Research. *The Accounting Review* 77(2), 453-474
- Bernard, V. L., 1995. The Feltham-Ohlson Framework: Implication for Empiricists. *Contemporary Accounting Research* 11(2), 733-747.
- Brown, L. D., J.C. Gardner, and M.A Vasarhelyi., 1987. An analysis of The Research Contributions of Accounting, Organizations, and Society 1976-1984. *Accounting Organizations and Society* 12(2), 193-204
- Brown, S., Kin Lo, and Thomas Lys., 1999. Use of R² in Accounting Research: Measuring Changes in Value Relevance over the Last Four Decades. *Journal of Accounting and Economics* 28(2), 83-115
- Brown, Philip., 1994. *Capital Market Research-Based in Accounting: An Introduction*. Australia: Coopers and Lybrand
- Brown, R., M. Jones, and T. Steele., 2007. Still Flickering at the Margins of Existence? Publishing Patterns and Themes in Accounting and Finance Research over the Last Two Decades. *The British Accounting Review* 39(2), 125-151
- Cho, J. Y. and K. Jung., 1991. Earnings Response Coefficients: A Synthesis of Theory and Empirical Evidence. *Journal of Accounting Literature* 10(1), 83-116
- Cooper, H. M., 2010. *Research Synthesis and Meta-Analysis: A Step-by-Step Approach*. California: Sage Publication
- Creswell, J.W., 2007. *Qualitative Inquiry & Research Design*. USA: Sage Publication
- Daske, H., L. Hail, C. Leuz, dan R. Verdi., 2008. Mandatory IFRS Reporting around the World: Early Evidence on the Economic Consequences. *Journal of Accounting Research* 46(5), 1085–1142.
- Deegan, C. M., 2000. *Financial Accounting Theory*. Australia: McGraw-Hill
- Dumontier, P., and B. Raffournier., 2002. Accounting and Capital Markets: A Survey of the European Evidence. *The European Accounting Review* 11(1), 119-151.
- Feltham, G. A., and J. A. Ohlson., 1995. Valuation and Clean Surplus Accounting for Operating and Financial Activities. *Contemporary Accounting Research* 11(2), 689-731.
- Gujarati, D. and D. C. Porter., 2009. *Basic Econometric*. 5th Edition. Singapore: McGraw-Hill International edition
- Hartoto., 2009. Penelitian Deskriptif. www.penalarnan-unm.org/index.../penelitian/163-penelitian-deskriptif.pdf. 24 Maret 2010.
- Healy, P. M., and K. G. Palepu., 2001. Information Asymmetry, Corporate Disclosure, and the Capital Markets: A Review of the Empirical Disclosure Literature. *Journal of Accounting and Economics* 31, 405-440.
- Heck, L. J., and W. G. Bremser., 1986. Six Decades of Accounting Review: A Summary of Authors and Institutional Contributors. *The Accounting Review* 61(4), 735-744.
- Hesford, J. W., Sung-Han (Sam) Lee, Wim A. Van der Stede, and S. M. Young. 2007. *Management Accounting: A Bibliographic Study, Handbook of Management Accounting Research*. USA: Elsevier
- Holthausen, R. W., and R. L. Watts. 2001. The Relevance of the Value-Relevance Literature for Financial Accounting Standard Setting. *Journal of Accounting and Economics* 31, 3-75
- Indriantoro, N. dan B. Supomo., 2002. *Metodologi Penelitian Bisnis untuk Akuntansi & Manajemen*. Yogyakarta: BPFE
- Jang, H. J. and Byung T. Ro., 1989. Trading Volume Theories and Their Implications for Empirical Information Content Studies. *Contemporary Accounting Research* 6(1), 242-262.
- Jeanjean, T., and H. Stolowy. 2008. Do Accounting Standards Matter? An Exploratory Analysis of Earnings Management Before and After IFRS Adoption. *Journal of Accounting and Public Policy* 27(6), 480-494
- Karpoff, J. M., 1986. A Theory of Trading Volume. *The Journal of Finance* 41(5), 1069-1087.
- Kothari, S. P., 2001. Capital Market Research in Accounting. *Journal of Accounting and Economics* 31, 105-231.

- Kothari, C.R., 2004. *Research Methodology Methods and Techniques*. 2nd Edition. New Delhi: New Age International (P) Limited
- Lestari, T. and Z. Baridwan., 2008. Pengaruh Amortisasi Goodwill terhadap Kegunaan Informasi Laba. *Jurnal Riset Akuntansi Indonesia* 11(3), 312-326.
- Lev, B., and J. A. Ohlson., 1982. Market-Based Empirical Research in Accounting: A Review, Interpretation, and Extension. *Journal of Accounting Research* 20(Supplement), 249-322.
- Luft, J., and M. D. Shields., 2003. Mapping Management Accounting: Graphics and Guidelines for Theory-Consistent Empirical Research. *Accounting Organizations and Society* 28, 169-249.
- Marfuah., 2006. Pengaruh Kecanggihan Investor terhadap Ketepatan Reaksi Pasar dalam Merespon Pengumuman Dividen Meningkatkan. *Jurnal Akuntansi dan Auditing Indonesia* 10(2), 183-206.
- Meek, G. K., and W. B. Thomas., 2004. A Review of Market-Based International Accounting Research. *Journal of International Accounting Research* 3(1), 21-41.
- Meyer, M., and J. T. Rigsby., 2001. Descriptive Analysis of the Content and Contributors of Behavioral Research in Accounting 1989-1998. *Behavioral Research in Accounting* 13, 253-278
- Rahmawati., 2005. Relevansi Nilai Earning dengan Pendekatan Terintegrasi: Hubungan Non Linear. *Jurnal Akuntansi dan Auditing Indonesia* 9(1), 57-77.
- _____, 2006. Relevansi Nilai Informasi Akuntansi dengan Pendekatan Terintegrasi: Hubungan Non Linear. *Jurnal Riset Akuntansi Indonesia* 9(2), 136-156.
- Scott, W. R., 2006. *Financial Accounting Theory*. 4th Edition. USA: Pearson Prentice Hall
- Sekaran, U., 2003. *Research Methods for Business: A Skill Building Approach*, 4th Edition. USA: John Willey & Sons, Inc.
- Setiawan, D. and S. Subekti., 2005. Pengujian Efisiensi Pasar Bentuk Setengah Kuat secara Keputusan: Analisis Pengumuman Dividen Meningkatkan (Studi Empiris pada BEJ selama Krisis Moneter). *Jurnal Riset Akuntansi Indonesia* 8(2), 121-137.
- Simon, J., 2007. Concept Mapping in a Financial Accounting Theory Course. *Accounting Education: An International Journal* 16(3) 273-308
- Soepratikno, N. I. and J. Hartono., 2005. Pengaruh Atribut Perusahaan terhadap Relevansi Laba dan Arus Kas. *Jurnal Riset Akuntansi Indonesia* 8(3), 211-234.
- Sumarni, A. S. and Rahmawati., 2007. Relevansi Nilai Informasi Arus Kas dengan Rasio Laba Harga dan Perubahan Laba Harga sebagai Variabel Moderasi: Hubungan Non Linear. *Jurnal Akuntansi dan Auditing Indonesia* 11(1), 21-33.
- Tandelilin, E., 2010. *Portofolio dan Investasi: Teori dan Aplikasi*. Yogyakarta: Kanisius
- Wirama, D. G., 2009. Validitas Empiris Model Valuasi Ohlson (1995). *Jurnal Riset Akuntansi Indonesia* 12(2), 145-160.

APPENDICES

Appendix 1

Map Notation

The map notation used in this research is adopted from Luft and Shields (2003).

I. Association study

1. Additive, linear, and unidirectional:



2. Intervening model, for example:



3. Interaction Model,

a. Ordinal (monotonic) model with general sign:

i. IV₂ or MV strengthen positive relationship of IV₁ – DV

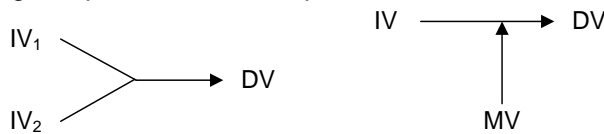

ii. IV₂ or MV strengthen negative relationship of IV₁ – DV

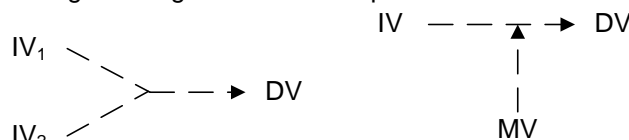

b. Ordinal Model with mixed-sign:

i. IV₂ or MV negatively influence the positive relationship of IV₁ – DV

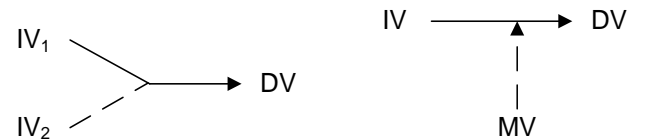

ii. IV₂ or MV positively influence the negative relationship IV₁ – DV

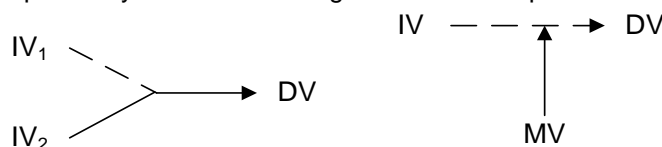

4. Nonlinear unidirectional relationship:

a. U relation: IV $\cdots\cdots\cdots$ DV

b. Inverted U relation: IV $\cdots\cdots\cdots$ DV

II. Construct-Variable relationship

1. Construct: informative event, sample divider factor (immeasurable)



2. Variable (measurable)



3. The relationship between construct and variable



Appendix 2 Fundamental Analysis and Valuation

Unit of analysis: Beyond organization

–

Unit of analysis: organization

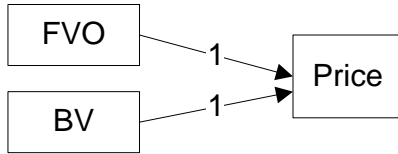

Unit of analysis: Organization subunit

–

Dependent variable:

1. Price: Market capitalization

Independent variable:

1. BV: Companies book value
2. NMO: Ohlson (1995) model value

Source:

1. Wirama (2009)

Appendix 3 Accounting regulation consequences

Unit of analysis: Beyond organization

–

Unit of analysis: organization

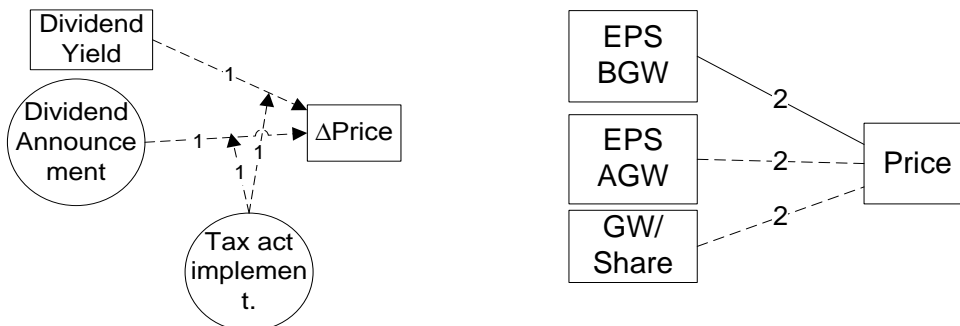

Unit of analysis: Organization subunit

–

Constructs:

1. Tax act implementation: The category of difference test to divide sample into before-and-after tax act amendment
2. Dividend announcement: An event of announcing dividend

Dependent variables:

1. Price: Stock price
2. ΔPrice: Stock price changes

Independent variables:

1. EPSAGW: EPS after goodwill amortization
2. EPSBGW: EPS before goodwill amortization
3. GW/Share: Goodwill amortization per share

Sources:

1. Alim and Hartini (2001)
2. Lestari and Baridwan (2008)

Appendix 4 Market Efficiency

Unit of analysis: Beyond organization

Unit of analysis: organization

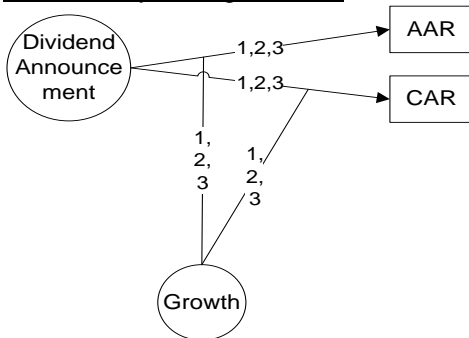

Unit of analysis: Organization subunit

Constructs:

- 1. Dividend Announcement: An event of announcing dividend
- 2. Growth: A category to divide sample into two groups i.e. growing and not growing, measured by market value equity/book value equity or capital expenditure/book value of asset)

Dependent variables:

- 1. AAR: Average abnormal return (market model)
- 2. CAR: Cumulative abnormal return (market model)

Sources:

- 1. Setiawan and Hartono (2003)
- 2. Setiawan and Subekti (2005)
- 3. Marfuah (2006).

Appendix 5 Performance Measure Consequences

Unit of analysis: Beyond organization

Unit of analysis: Organization

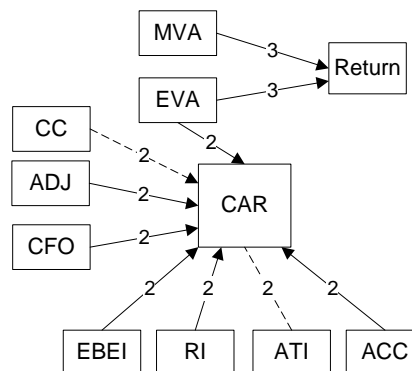
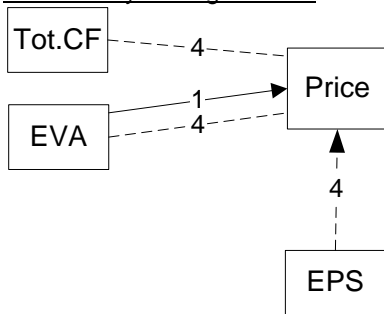

Unit of analysis: Organization subunit

Dependent variables:

- 1. CAR: Cumulative abnormal return
- 2. Price: Stock price
- 3. Return: Stock return

Independent variables:

- | | | | |
|------------|-----------------------|----------|------------------------------------|
| 1. ACC: | Accrual | 6. CFO: | Operating cash flow |
| 2. ADJ: | Accounting adjustment | 7. EBEI: | Earnings before extraordinary item |
| 3. ATI: | After tax interest | 8. EPS: | Earnings per share |
| 4. CC: | Capital charge | 9. EVA: | Economic value added |
| 5. Tot.CF: | Cash flow | 10. MVA: | Market value added |
| | | 11. RI: | Residual income |

Sources:

- | | |
|--------------------|---|
| 1. Ekadjaja (2006) | 3. Madiah, Sugiarto, and Siagian (2006) |
| 2. Hidayat (2006) | 4. Sriwahyuni (2007) |

Appendix 6 Accounting Disclosure Consequences

Unit of analysis: Beyond organization

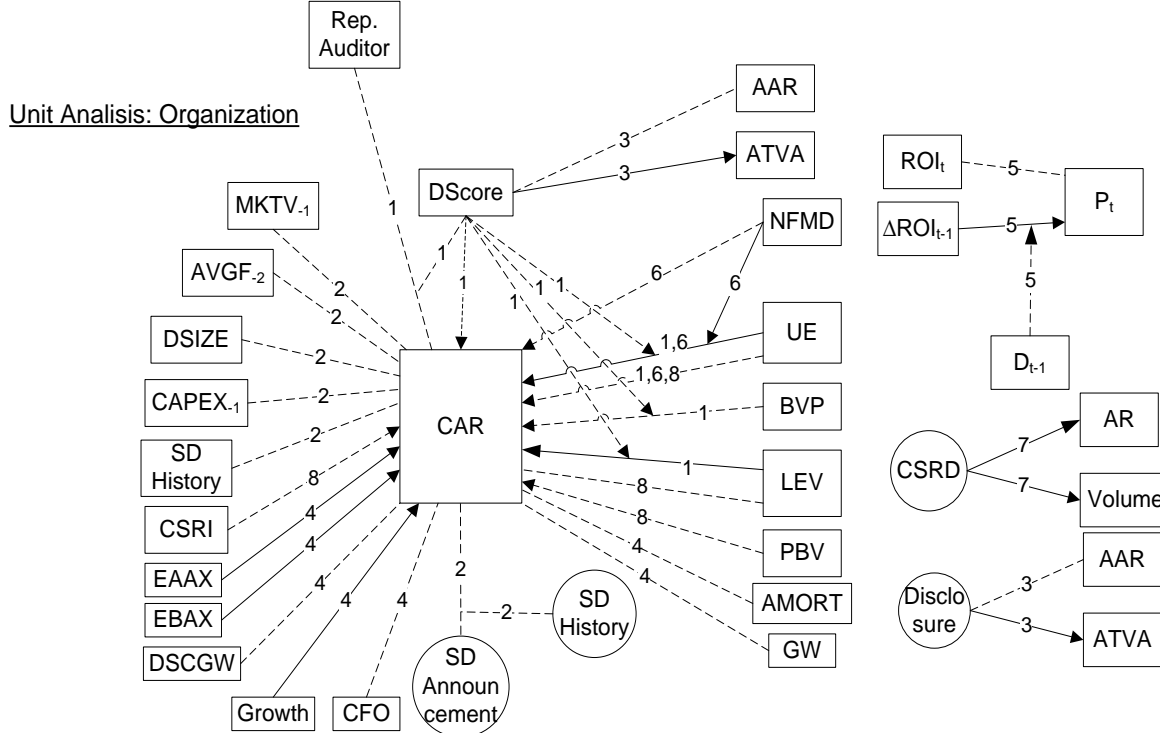

Unit of analysis: Organization subunit

Constructs:

- | | |
|-----------------|--|
| 1. CSRD: | Corporate social responsibility disclosure index, sample divider |
| 2. Disclosure: | Announcement of financial statement |
| 3. SD Announce: | Stock dividend announcement |
| 4. SD History | Stock dividend history, sample divider |

Dependent variables:

- | | |
|-----------|--|
| 1. AAR: | Average Abnormal return |
| 2. AR: | Abnormal return |
| 3. ATVA: | Average trading volume activity |
| 4. CAR: | Cumulative abnormal return (size adjusted model) |
| 5. Price: | Stock price |
| 6. TVA: | Stock trading volume |

Independent variables:

- | | |
|-------------------------|--|
| 1. ΔROI_{t-1} : | ROI Changes |
| 2. AMORT: | The ratio of goodwill amortization expense and income after amortization |
| 3. $AVGF_{-2}$: | Two years operating cash flow average |
| 4. BVP: | Book value per share |
| 5. $CAPEX_{-1}$: | Capital expenditure |
| 6. CFO: | Operating cash flow |
| 7. CSRD: | Corporate social responsibility disclosure |
| 8. CSRI: | Corporate social responsibility index |
| 9. DSCGW: | Goodwill disclosure rate |
| 10. DSIZE: | Dummy for firm size |

- 11. EAAX: Earning after goodwill amortization and extraordinary item
- 12. EBAX: Earning before goodwill amortization and extraordinary item
- 13. Growth: Company growth
- 14. GW: Goodwill portion of asset
- 15. LEV: Leverage
- 16. MKTV₋₁: Market value of equity
- 17. NFMD: Nonfinancial measure disclosure
- 18. PBV: Price-to-equity book value
- 19. Rep. Auditor: Auditor reputation
- 20. ROI_t: Return on investment
- 21. SD History: Stock dividend history
- 22. UE: Unexpected earning

Moderating variables:

- 1. D_{t-1}: Disclosure index for period t-1
- 2. Dscore: Disclosure index

Sources:

- 1. Adhariani (2005)
- 2. Aloysius (2005)
- 3. Junaedi (2005)
- 4. Anindhita and Martani (2006)
- 5. Ardiansyah (2007)
- 6. Wondabio (2007)
- 7. Yuliana et al. (2008)
- 8. Celia and Bangun (2009)

Appendix 7A Discretionary Behavior

Unit of analysis: organization

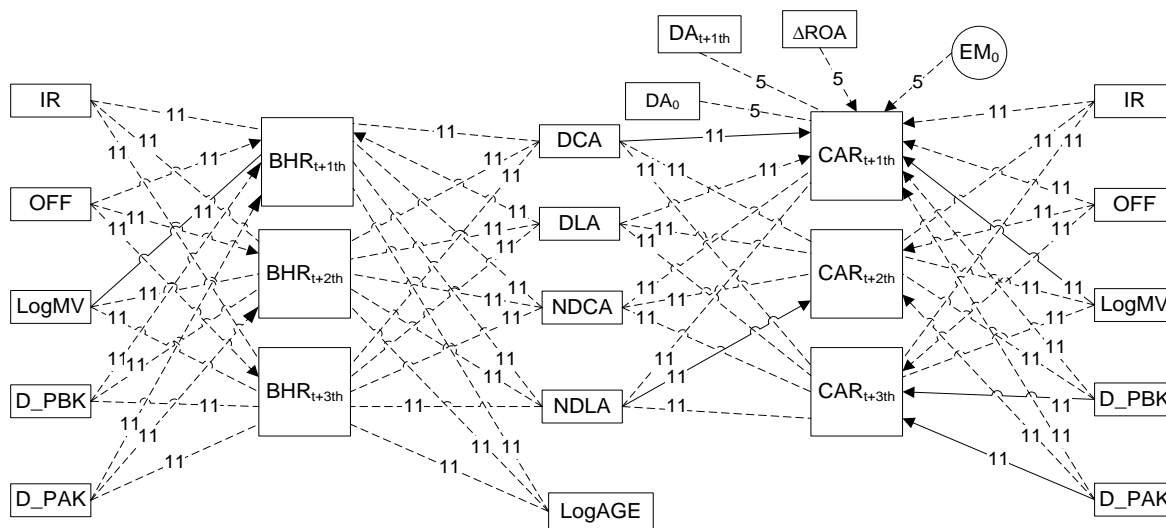

Appendix 7B Discretionary Behavior

Unit of analysis: Beyond organization

Unit of Analysis: Organization

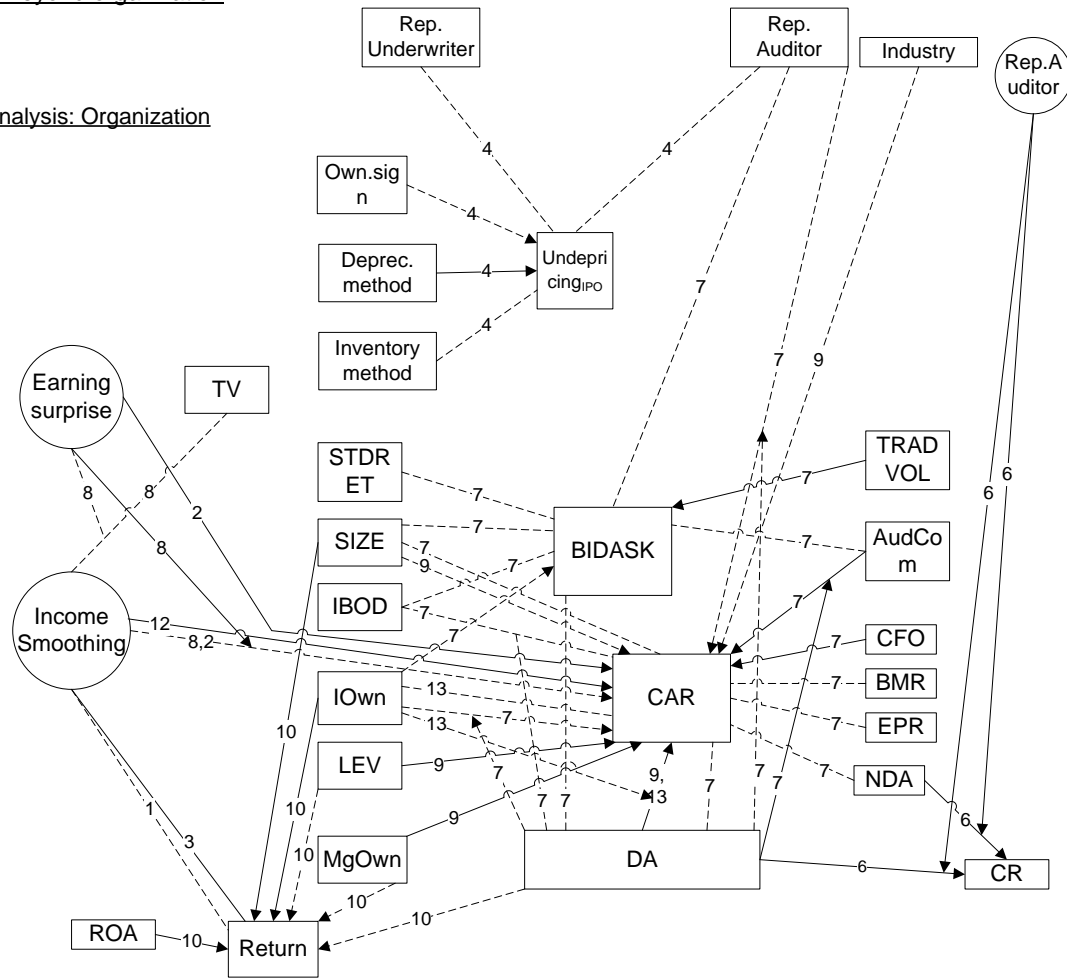

Unit of analysis: Organization Subunit

Constructs:

- 1. Rep. Auditor: Auditor reputation, sample divider
- 2. Earning surprise: Sample divider
- 3. Income smoothing: Sample divider (smoother vs. non-smoother)
- 4. IPO: Initial public offering

Dependent variables:

- 1. BHR_{t+n}: Buy and hold return after IPO
- 2. BIDASK: Bid-ask spread
- 3. CAR: Cumulative abnormal return
- 4. CAR_{t+n}: Cumulative abnormal return after IPO
- 5. CR: Cumulative return.
- 6. Return: Stock return
- 7. TVA: Trading volume activity
- 8. Under-pricing: The gap between first closing price in secondary market and initial price in primary market

Independent variables:

- 1. ΔROA: Changes of return on asset
- 2. AudCom: The dummy of audit committee
- 3. Rep. Auditor: The dummy of auditor reputation
- 4. BMR: Book-to-market ratio
- 5. CFO: Operating cash flow
- 6. D_PAK: The dummy of IPO date after crisis
- 7. D_PBK: The dummy of IPO date after crisis
- 8. DA: Discretionary accrual
- 9. DA₀: Discretionary accrual at IPO date
- 10. DA_{t+1th}: Discretionary accrual at year after IPO
- 11. DCA: Discretionary current accrual at IPO date
- 12. DLA: Discretionary long-term accrual at IPO date
- 13. EPR: Earning-to-price

14.	IBOD:	Independent board
15.	Industry:	The dummy of industry
16.	IOwn:	Institutional ownership
17.	IR:	Initial return
18.	LEV:	Leverage
19.	LogAGE:	Company age
20.	LogMV:	Firm market value
21.	Deprec. method:	Depreciation method
22.	Inventory method:	Inventory method
23.	MgOwn:	Managerial ownership
24.	NDA:	Non-discretionary Accrual
25.	NDCA:	Non-discretionary current accrual
26.	NDLA:	Non-discretionary long-term accrual
27.	OFF:	Offering price
28.	Rep. underwriter:	Underwriter reputation
29.	ROA:	Return on asset
30.	Own. sign:	Ownership signal
31.	SIZE:	Firm size
32.	STDRET:	Stock return deviation standardized
33.	TRADVOL:	Average of trading volume

Moderating variables:

1.	DA:	Discretionary accrual
----	-----	-----------------------

Sources:

- | | | | |
|----|-------------------------------|-----|------------------------------|
| 1. | Salno and Baridwan (2000) | 8. | Juniar <i>et al.</i> (2006) |
| 2. | Assih and Gudono (2000) | 9. | Sukartha (2007) |
| 3. | Prasetio <i>et al.</i> (2002) | 10. | Widyastuti (2007) |
| 4. | Ali and Hartono (2003) | 11. | Rahman and Hutagaol (2008) |
| 5. | Saiful (2004) | 12. | Oktorina and Hutagaol (2009) |
| 6. | Ardiati (2005) | 13. | Joni and Hartono (2009) |
| 7. | Veronica and Bachtiar (2005) | | |

Appendix 8 Earnings Response Coefficient

Unit of Analysis: Beyond Organization

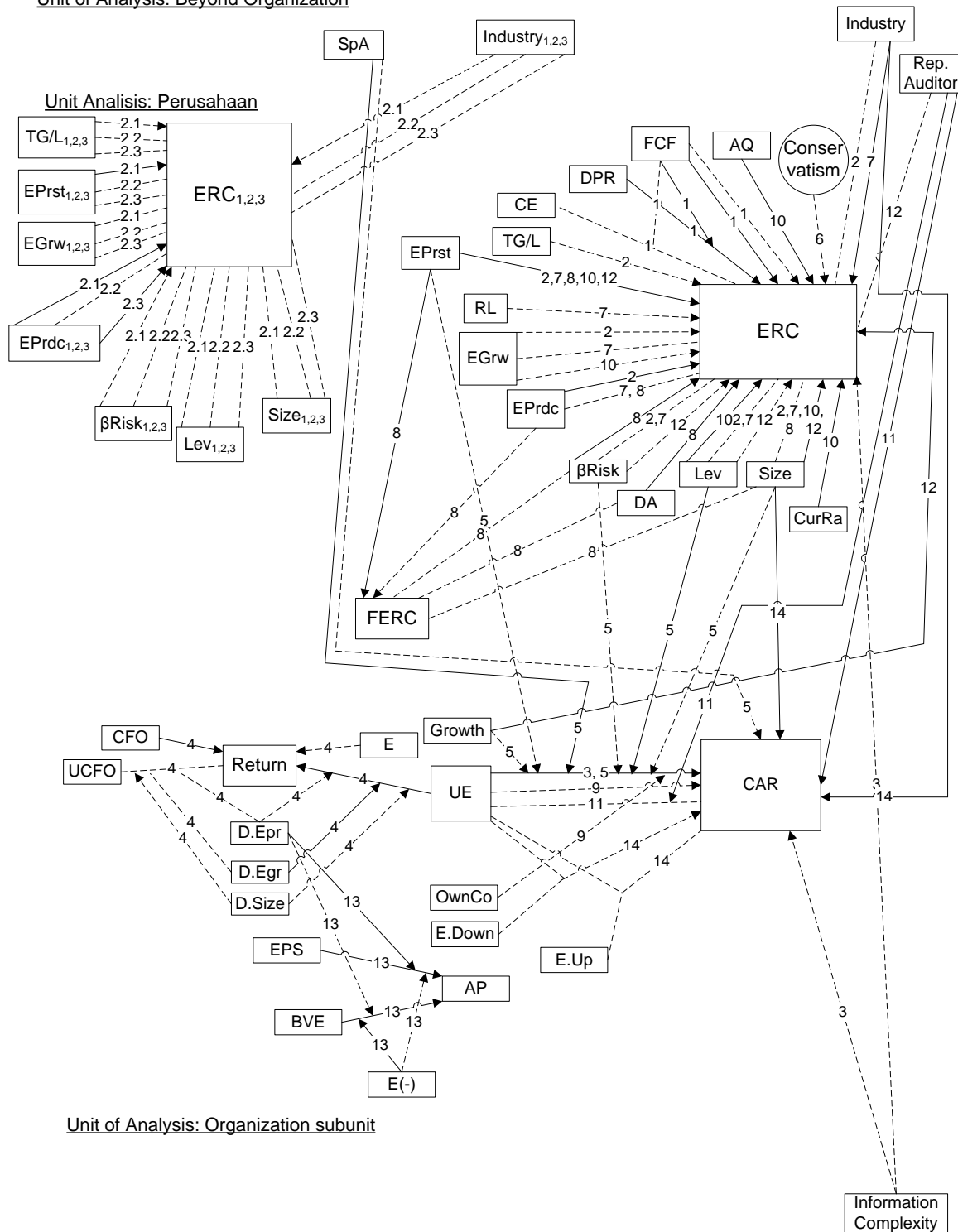

Unit of Analysis: Organization subunit

Constructs:

- 1. Conservatism: Sample divider (conservative and other)

Dependent variable

- 1. AP: Adjusted stock price
- 2. CAR: Cumulative abnormal return
- 3. ERC: Earnings response coefficient
- 4. ERC_{1,2,3}: Earnings response coefficient for particular sample
- 5. FERC: Future ERC
- 6. Return: Stock return

Independent variables:

- 1. AQ: Accrual quality
- 2. BVE: Book value of equity per share

3.	CE:	Capital expenditure
4.	CFO:	Operating cash flow
5.	CurRa:	Current ratio
6.	DA:	Discretionary accrual
7.	DPR:	Dividend pay-out ratio
8.	Earnings:	Firms income
9.	EGrw:	Earnings growth
10.	EGrw _{1,2,3} :	Earnings growth for particular sample
11.	EPrdc:	Earnings predictability
12.	EPrdc _{1,2,3} :	Earnings predictability for particular sample
13.	EPrst:	Earnings persistency
14.	EPrst _{1,2,3} :	Earnings persistency for particular sample
15.	EPS:	Earnings per share
16.	FCF:	Free cash flow
17.	Industry:	The dummy for industry
18.	Industry _{1,2,3} :	The dummy for industry for particular sample
19.	Information complexity	
20.	Lev:	Leverage
21.	Lev _{1,2,3} :	Leverage for particular sample
22.	Rep. Auditor:	Auditor reputation
23.	RL:	Reporting lag
25.	Size _{1,2,3} :	Firm size for particular sample
26.	SpA:	Auditor specialization
27.	TG/L:	Foreign currency gain/loss
28.	TG/L _{1,2,3} :	Foreign currency gain/loss for particular sample
29.	UCFO:	Unexpected operating cash flow
30.	UE:	Unexpected earnings
31.	β Risk:	Risk
32.	β Risk _{1,2,3} :	Risk for particular sample

Moderating variables:

1.	Rep. Auditor:	Auditor reputation
2.	D.Egr:	Dummy for earnings growth
3.	D.EPr:	Dummy for earnings persistency
4.	D.Size:	Dummy for firm size
5.	E(-):	Dummy negative income
6.	E.Down:	Unexpected negative income
7.	E.Up:	Unexpected positive income
8.	FCF:	Free cash flow
9.	Growth:	Firms growth
10.	OwnCo:	Ownership concentration
11.	SpA:	Auditor specialization

Sources:

1.	Uyara and Tuasikal (2003)	8.	Bonny <i>et al.</i> (2004)
2.	Chandrarin (2003), which divided into 2.1, 2.2, and 2.3	9.	Febrianto (2005)
3.	Kusuma (2003)	10.	Jang <i>et al.</i> (2006)
4.	Diana and Kusuma (2003)	11.	Setiawati (2006)
5.	Mayangsari (2004)	12.	Mulyani <i>et al.</i> (2007)
6.	Dewi (2004)	13.	Naimah and Utama (2007)
7.	Jaswadi (2004)	14.	Sugiri and Sumiyana (2009)

Appendix 9 Accounting Information Content

Unit of analysis: Beyond organization

Unit of analysis: Organization

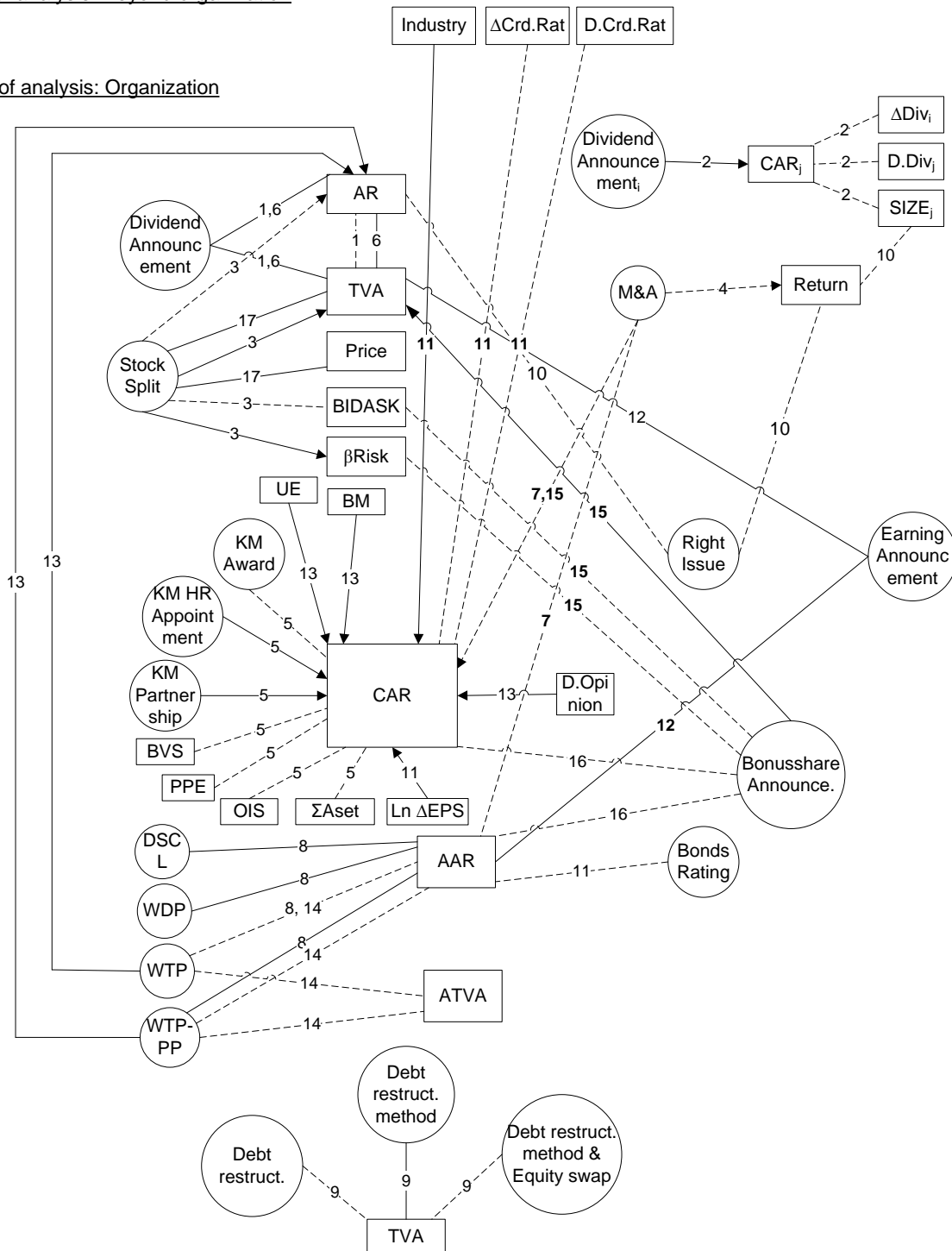

Unit of analysis: Organization subunit

Constructs:

- | | |
|------------------------------|--|
| 1. Bonds rating: | Bonds rating announcement |
| 2. Bonus-share announcement: | Bonus-share announcement |
| 3. Dividend announcement: | Dividend announcement |
| 4. Dividend announce: : | Dividend announcement of particular sample |
| 5. DSCL: | Disclaimer audit opinion |
| 6. Earning announcement: | Earning announcement |
| 7. KM Award: | Knowledge management award |
| 8. KM HR Appointment: | Publication of knowledge management expert appointment |

9.	KM Partnership:	Publication of knowledge management partnership
10.	M&A:	Merger and acquisition announcement
11.	Debt restruct. method& Equity swap:	Sample divider based on the uses of debt restructuring method and equity swap
12.	Debt restruct. method:	Sample divider based on the uses of debt restructuring method
13.	Debt restruct.	Sample divider based on the existence of debt restructuring
14.	Right issue	Right issue announcement
15.	Stock split:	Stock split event
16.	WDP:	Qualified audit opinion
17.	WTP:	Unqualified audit opinion
18.	WTP-PP:	Unqualified audit opinion with explanatory paragraph

Dependent variables:

1.	AAR:	Average abnormal return
2.	AR:	Abnormal return
3.	ATVA:	Abnormal trading volume
4.	BIDASK:	Bid-ask spread
5.	CAR:	Cumulative abnormal return
6.	CAR _j :	Cumulative abnormal return for particular sample
7.	Price:	Stock price
8.	Return:	Stock Return
9.	TVA:	trading volume
10.	βRisk:	Firm risk

Independent variables:

1.	ΔCrd.Rat:	Credit rating changes
2.	ΔDiv _j :	Dividend changes of particular firm
3.	BMR:	Book to market ratio
4.	BVS:	Book value per share
5.	D.Crd.Rat:	Dummy for credit rating
6.	D.Div _j :	Dummy dividend changes of particular firm
7.	D.Opinion:	Dummy for audit opinion
8.	Industry:	Dummy for industry
9.	Ln ΔEPS:	EPS Changes
10.	OIS:	Operating income before depreciation
11.	PPE:	Property and plant
12.	SIZE _j :	Firm size of particular firm
13.	UE:	Unexpected earning
14.	ΣAset:	Total asset

Sources:

1.	Bandi & Hartono (2000)	7.	Sutrisno & Sumarsih (2004)	13.	Leo (2007)
2.	Yusnitasari (2003)	8.	Pujadi <i>et al.</i> (2005)	14.	Meiden (2007)
3.	Kurniawati (2003)	9.	Aloysius (2006)	15.	Gudono (2007)
4.	Payamta & Setiawan (2003)	10.	Hastuti & Nurhana (2006)	16.	Kurniawati (2007)
5.	Warsono (2004)	11.	Karyani & Manurung (2006)	17.	Tanjung (2007)
6.	Meiden <i>et al.</i> (2004)	12.	Kurniawati (2006)		

Appendix 10 A Value Relevance Study

Unit of analysis: Beyond organization

Unit of analysis: Organization

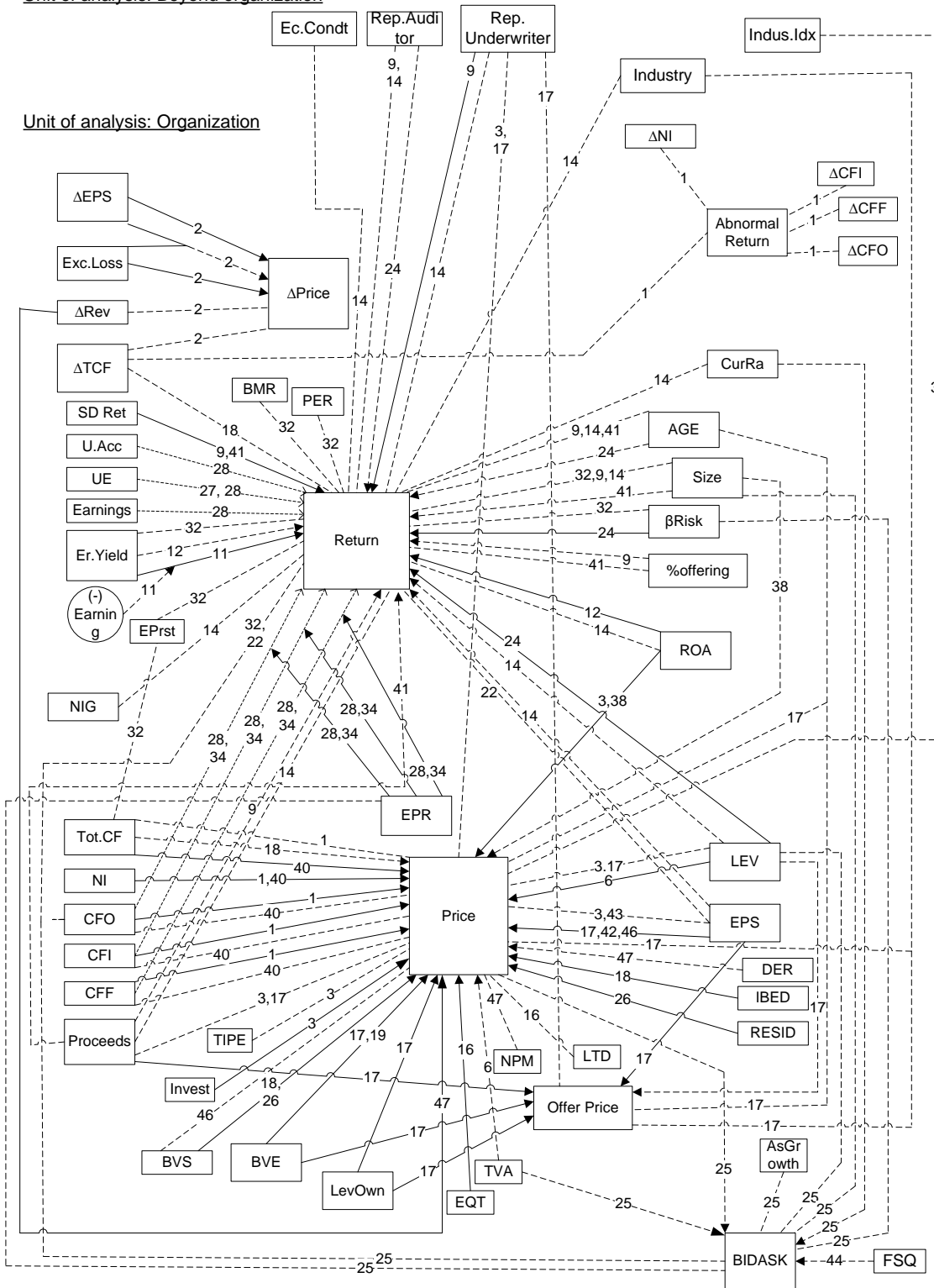

Appendix 10 C Value Relevance Study

Unit of analysis: Organization

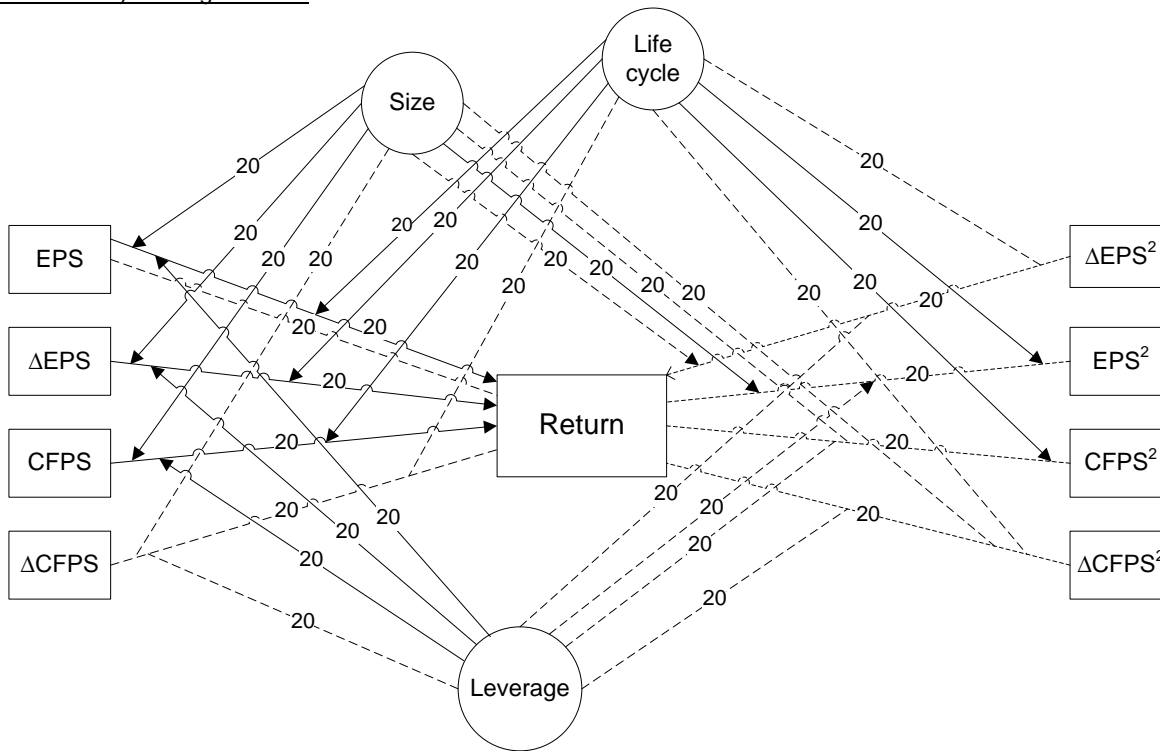

Unit of analysis: Organization subunit

Constructs:

- | | |
|---------------------------|---|
| 1. (-) <i>Earning</i> : | Negative earnings |
| 2. Accounting information | |
| 3. Strategy: | Sample divider based on the strategy used |

Dependent variables:

- | | |
|--------------------------|---|
| 1. Δ Price: | The price changes |
| 2. AR: | Abnormal return |
| 3. CAR: | Cumulative abnormal return |
| 4. Frequency: | Trading frequency |
| 5. MRR ^{D(E)} : | Average raw return around dividend announcement |
| 6. Price: | Stock price |
| 7. Return: | Stock return |

Independent variables:

- | | |
|---------------|--|
| 1. %Offering: | Ownership percentage offered in IPO |
| 2. Δ EPS: | EPS Changes |
| 3. Δ NI: | Net income Changes |
| 4. ΔBVS: | Book value per share changes |
| 5. ΔCFF: | Financing cash flow changes |
| 6. ΔCFI: | Investment cash flow changes |
| 7. ΔCFO: | Operating cash flow changes |
| 8. ΔDPS: | Dividend per share changes |
| 9. ΔIBED: | The changes of income before <i>extraordinary item</i> and <i>discontinued operation</i> |
| 10. ΔRev: | Revenue changes |
| 11. ΔROE: | Return on equity changes |
| 12. ΔTCF: | Total cash flow changes |
| 13. AGE: | Firm age |
| 14. AsGrowth: | Asset growth |
| 15. BMR: | Book-to-market ratio |
| 16. BoExp: | Board experience |
| 17. BoSize: | Board size |
| 18. BVE: | Book value of equity |
| 19. BVS: | Book value per share |
| 20. CFF: | Financing cash flow |
| 21. CFI: | Investment cash flow |
| 22. CFO: | Operating cash flow |

23.	CurRa:	<i>Current ratio</i>
24.	D.Prm:	Dividend Premium
25.	D.Yield:	Dividend <i>Yield</i> (DPS/stock price)
26.	DE (+/-+/-+):	Dummy of dividend announcement before earning announcement for the condition of dividend increase and income decrease/ dividend increase and income increase/dividend decrease and income increase.
27.	DFTX:	Deferred tax
28.	DNEN:	Dummy for dividend increase and income increase
29.	DNET:	Dummy dividend increase and income decrease
30.	DPR:	Dividend payout ratio
31.	DPS:	Dividend per share
32.	DTBEN:	Dummy for dividend unchanged and income increase
33.	DTBET:	Dummy for dividend unchanged and income decrease
34.	DTEN:	Dummy for dividend decrease and income increase
35.	Earnings:	Accounting income
36.	Ec.Condt:	<i>Dummy</i> for economic condition
37.	ED (+/-+/-+):	Dummy of earning announcement before dividend announcement for the condition of income increase and dividend decrease/income increase and dividend increase/income decrease and dividend increase
38.	EDU:	Board education
39.	EPS:	<i>Earnings per share</i>
40.	EQT:	Stockholder equity
41.	Er.Yield:	Earnings yield (EPS/stock price)
42.	EPR:	<i>Earning</i> per stock price ratio
43.	FSQ:	Financial statement quality
44.	Growth:	Firm growth
45.	IBED:	Income before <i>extraordinary item</i> and <i>discontinued operation</i>
46.	Indus.Idx:	Index of average Industry stock price
47.	Industry:	<i>Dummy</i> for industry
48.	Invest:	<i>Investment Proceeds</i>
49.	IOwn:	Institutional ownership
50.	JII:	<i>Jakarta Islamic Index</i>
51.	ExRate:	Rupiah to dollar exchange rate
52.	KwaSP:	Absolute announcement timeline after audit
53.	Lev:	<i>Leverage</i>
54.	LevOwn:	Ownership level
55.	LnDiv:	Dividend
56.	LTD:	<i>Long-term debt</i>
57.	MIMR ^{D(E)} :	Weighted average market return around dividend announcement
58.	NI:	Net income
59.	NIG:	Net income growth
60.	OPM:	<i>Operating profit margin</i>
61.	PBV:	<i>Price-to-book value of equity ratio</i>
62.	PER:	<i>Price-to-earnings ratio</i>
63.	PPAP:	Productive asset allowance
64.	PREV:	Board experience
65.	Proceeds:	Proceeds of equity offered
66.	RE:	Retained earnings
67.	Rep. Auditor:	Auditor reputation
68.	Rep. Underwriter:	<i>Underwriter</i> reputation
69.	RESID:	<i>Residual earnings</i>
70.	Return _{t-x} :	Average <i>return</i> for certain time
71.	ROA:	<i>Return on assets</i>
72.	ROE:	<i>Return on equity</i>
73.	SD Ret:	Standardized deviation of stock return
74.	Size:	Firm size
75.	TAC:	Total accrual
76.	TIPE:	Types of offering
77.	Tot.CF:	Total cash flow
78.	TVA:	Trading volume
79.	U.Acc:	Unexpected accrual
80.	UE:	<i>unexpected earning</i>
81.	UGP:	<i>Unexpected gross profit</i>
82.	UNI:	<i>Unexpected net income</i>
83.	UOI:	<i>Unexpected operating income</i>
84.	βRisk:	Firm risk
Moderating variables:		
1.	IOS:	Investment opportunity set
2.	ΔDPS:	Dividend per share changes
3.	ΔEPS:	EPS Changes

4. EPR: *Earning per stock price ratio*
 5. Exc.Loss: Dummy for exchange loss

Intervening variables

1. EPrst: Earnings persistency

Sources:

- | | | |
|--------------------------------|-----------------------------------|----------------------------------|
| 1. Triyono & Hartono (2000) | 17. Gumanti (2005) | 33. Susanto (2007) |
| 2. Chandrarin & Tearney (2000) | 18. Linda & Syam (2005) | 34. Sumarni & Rahmawati (2007) |
| 3. Payamta (2000) | 19. Jadi (2005) | 35. Handary <i>et al.</i> (2008) |
| 4. Subekti & Kusuma (2001) | 20. Soepratikno & Hartono (2005) | 36. Wirakusuma (2008) |
| 5. Habbe & Hartono (2001) | 21. Yuniasih (2005) | 37. Astuty & Siregar (2008) |
| 6. Pujiono (2002) | 22. Spartha & Febrewaty (2005) | 38. Aini & Sumiyana (2008) |
| 7. Marfuah (2002) | 23. Dewi (2005) | 39. Damayanti (2008) |
| 8. Tuasikal (2002) | 24. Meiden <i>et al.</i> (2005) | 40. Keni (2008) |
| 9. Nasirwan (2002) | 25. Tumirin (2005) | 41. Hastuti (2008) |
| 10. Handoyo (2002) | 26. Suwardi (2005) | 42. Murni (2008) |
| 11. Ajie (2003) | 27. Rahmawati (2005) | 43. Endri (2008) |
| 12. Meiden & Toumahu (2003) | 28. Rahmawati (2006) | 44. Fanani (2009) |
| 13. Murni (2003) | 29. Febrianto & Widiastuty (2006) | 45. Riadi (2009) |
| 14. Ardiansyah (2004) | 30. Ria & Husnah (2006) | 46. Wijaya (2009) |
| 15. Hartono (2004) | 31. Gumanti & Wianandi (2007) | 47. Ayu & Handoyo (2009) |
| 16. Maryanto & Muchlis (2004) | 32. Meythi (2007) | |