

From distractions to detox: analyzing how recovery experiences mediate the relationship between social cyberloafing and social sustainability

Jawad Abbas

*Faculty of Management Sciences, University of Central Punjab,
Lahore, Pakistan and*

Faculty of Business and Economics, Near East University, Nicosia, North Cyprus

Marina Dabic

*Department of International Economics, Faculty of Economics and Business,
University of Zagreb, Zagreb, Croatia;*

*Faculty of Economics and Business, University of Dubrovnik,
Dubrovnik, Croatia;*

*CEREFIGE, ICN Business School, Université de Lorraine, Nancy, France and
School of Economics and Business, University of Ljubljana, Ljubljana, Slovenia, and*

Tilo Halaszovich

CEREFIGE, ICN Business School, Université de Lorraine, Nancy, France

Abstract

Purpose – Society 5.0, which places humans at the forefront, utilizes Industry 4.0 technologies to enhance social sustainability and quality of life. This study takes an innovative approach by investigating the role of social cyberloafing in promoting social sustainability in small and medium-sized enterprises (SMEs) through integrating technological recovery experiences, such as relaxation, psychological detachment, mastery experiences, and control during leisure.

Design/methodology/approach – Employing the effort recovery model, this study explains whether social cyberloafing affects social sustainability. The empirical data from two hundred and fifty-four individuals from manufacturing and services SME firms in Turkey were collected and analyzed via a structural equation model.

Findings – Structural analysis indicates that social cyberloafing positively impacts employees' social sustainability and recovery experiences. Moreover, two constructs of recovery experiences, psychological detachment and relaxation, fully mediate the relationship between social cyberloafing and social sustainability, whereas mastery experiences and control during leisure play insignificant roles.

Practical implications – These findings challenge the traditional management view of cyberloafing as harmful and distracting. They demonstrate that social cyberloafing can be a beneficial recovery experience, but excessive cyberloafing can also hinder social performance. This insight is crucial for managers and policy-makers, who should consider the holistic effects of social cyberloafing on social sustainability.

Originality/value – This study offers novel contributions to the effect of social cyberloafing on the social sustainability of SME firms' employees. The findings illustrate how social cyberloafing can serve as a recovery



experience and improve social sustainability; however, excessive cyberloafing can also hinder social performance. SMEs must be aware of this potential downside and manage cyberloafing effectively.

Keywords Social cyberloafing, Recovery experiences, Social sustainability, Society 5.0

Paper type Research paper

1. Introduction

In the current digital era, humanity has witnessed a significant change in almost every aspect of life, including work, industry, and society (Dabić *et al.*, 2023; Švarc and Dabić, 2023; Švarc *et al.*, 2024; Alwadain *et al.*, 2024). Digital technologies, such as social media platforms, mobile applications, artificial intelligence, etc., are double-edged swords, improving well-being and quality of life (Abbas, 2024) while negatively affecting society through unemployment and human behavior (Figueroa *et al.*, 2023). Industry 4.0 encompasses a variety of digital technologies under its umbrella, with social media garnering considerable attention in particular (Ali and Johl, 2023). Facebook is one of the world's most popular social media sites, with over 3.05 billion active users. Similarly, WhatsApp and Instagram, widespread among the younger generation, have 3.03 and 2.0 billion users, respectively (Statista, 2024). According to Kemp (2023), as of April 2023, there were approximately 5.44 billion internet users, and approximately 5.07 billion (93.3%) used social media monthly. Although social media has significantly increased workplace productivity (Kanwal *et al.*, 2024; Mao *et al.*, 2022), it has presented the business world with a unique set of challenges, including cyberloafing behavior, which refers to employees' use of the Internet during office time to check personal emails and browse nonwork-related websites (Ali, 2024; Lim and Teo, 2024).

Cyberloafing has emerged as an intriguing topic, revealing the dual nature of its dark and positive effects (Zhang *et al.*, 2024). Scholars have studied it from different perspectives. For example, Korzynski and Protsiuk (2024) studied cyberloafing with employees' time management abilities and concluded that employees who engage in cyberloafing rarely perform their tasks on time. Tan *et al.* (2024a, b) examined how cyberloafing impacts nursing students' academic performance and mental well-being and reported a negative relationship. In contrast, Tsai (2023) highlighted the positive aspects of cyberloafing, showing that cyberloafing is positively associated with employees' innovation performance and resourcefulness. Similarly, Ma *et al.* (2023) stated that publicly and privately owned social media contributed to employee job satisfaction and performance. Nevertheless, there has been a recent shift in perspective, with scholars suggesting that cyberloafing can serve as a coping strategy at the individual and firm levels (Lim and Teo, 2024; Yang *et al.*, 2023; Yu *et al.*, 2024). This emerging aspect underscores the nuanced exploration of cyberloafing as a promising area of research. This concept has gained considerable attention in diverse domains, such as counterproductive work behavior (Bhattacharjee and Sarkar, 2024), job satisfaction (Zhang *et al.*, 2024), and ostracism (Koay and Lai, 2023).

This study focuses on the social aspect of cyberloafing in SMEs since more than 93% of internet users benefit from social media (Kemp, 2023). Social cyberloafing occurs when employees access social media sites during work (Koay and Lai, 2023). When people engage in social cyberloafing, as opposed to traditional cyberloafing, they are primarily involved in checking social media feeds, chatting with friends, or browsing social networking sites while at work (Bhattacharjee and Sarkar, 2024). Workers spending too much time on social media instead of concentrating on their jobs can cause them to lose productivity, become distracted, and perform worse (Al Frijat *et al.*, 2024; Alwadain *et al.*, 2024). Moreover, social cyberloafing plays a vital role in fostering the ideas of Society 5.0 by facilitating connectivity, collaboration, and the exchange of knowledge across diverse communities (Figueroa *et al.*, 2023).

Cyberloafing research has focused primarily on efficiency and individual work-related outcomes, with a lack of focus on social sustainability, particularly well-being and quality of life. This study focuses on social cyberloafing's role in employees' social sustainability in Turkish SMEs. It investigates how technological recovery experiences, such as psychological detachment, control during leisure time, relaxation, and personal mastery, contribute to their relationship. Focusing on SMEs' employees has strategic significance, given this sector's crucial role in the country's economy and labor market. Unlike large firms, SMEs have unique characteristics, such as human, financial, and related resource constraints and limited business portfolios. The close-knit nature of small firms allows employee behavior to impact overall organizational culture and performance (Abbas *et al.*, 2025).

Turkey's vibrant economic landscape and distinct cultural milieu provide a unique and compelling setting to explore the role of technological recovery experiences in mitigating the effects of social cyberloafing. Understanding this context is crucial, as Turkish small businesses face unique obstacles, including rapid industrialization, pressures from globalization, and a workforce becoming more involved with digital technology. By focusing on this sector, the research can provide valuable insights into how employee behavior, recovery strategies, and employee social sustainability interact, leading to a more comprehensive understanding of social sustainability in a critical yet overlooked economic sector. Using the effort–recovery model (ERM), this study develops a theoretical framework that contributes to the literature on social cyberloafing in the SME context within the Society 5.0 framework by highlighting positive contributions to employees' quality of life and well-being.

2. Literature review

2.1 Effort–recovery model (ERM)

This study builds on the arguments of Meijman and Mulder (1998) regarding the use of ERM. ERM has been applied predominantly to job satisfaction, mental health, and academic experiences (Wu *et al.*, 2020a, b). According to Wu *et al.* (2020a, b), ERM underscores the importance of employees taking periodic work breaks to maintain optimal productivity. This finding also suggests that shorter breaks are more beneficial than longer ones. ERM posits that intense work can lead to mental strain and exhaustion, resulting in adverse load reactions that are usually reversible during recovery times (Meijman and Mulder, 1998). However, insufficient psychological and physiological recovery may lead to the ongoing depletion of resources, increasing workload reactions over time and potentially causing long-term health problems and emotional burnout (Sonnentag and Fritz, 2007). Employees who engage in recovery activities outside work hours might return to their stressed emotional and physical states (She and Li, 2023). According to Herhausen *et al.* (2023), social media use is a minor effort–recovery action that can replenish resources during free time. This study argues that social cyberloafing in SMEs is positively associated with employee recovery experiences through psychological detachment, relaxation, mastery, and control during leisure time. It also promotes employees' social sustainability, a core aspect of Society 5.0.

2.2 Social cyberloafing and social sustainability

Lim (2002) first coined cyberloafing as “the voluntary act of employees using their organizational internet during office hours to surf non-job-related websites for personal purposes.” Several terms, such as cyberbludging, cyberslacking, and online loafing, describe similar behavior (Derin and Gökçe, 2016). Wu *et al.* (2020a, b) expanded this aspect to social activities and defined social cyberloafing as employees using private or organizational IT resources in the workplace to engage in social media activities. In the literature, cyberloafing has been studied with different variables, such as academic performance (Lim and Teo, 2024), employee mental health (Korzynski and Protsiuk, 2024), creativity (Bhattacharjee and Sarkar, 2024), job burnout, and innovative work behavior (Tsai, 2023). Most studies have highlighted

its adverse effects, such as diminished organizational productivity, information security breaches, and abusive supervision. At the behavioral level, it can also trigger negative emotions and psychological stress (Zhang *et al.*, 2024) and reduce work engagement (O'Neill *et al.*, 2014). However, not all researchers in the field share such a negative view of cyberloafing. A small or moderate level of cyberloafing is not harmful (Ohana *et al.*, 2024); it can help achieve good academic performance and mental health, reduce workplace aggression and innovative work behavior, and increase employee productivity (She and Li, 2023).

Employees' tendency to engage in cyberloafing continues to grow as ICT development and lower costs make the Internet more readily available. However, cyberloafing can occur in many ways, and the outcomes vary greatly (Tan *et al.*, 2024a, b). The influence of social cyberloafing on employees is a noteworthy concern, considering its broad popularity among young individuals (Hu *et al.*, 2023). Akar and Coskun (2020) reported a positive and significant relationship between instructors' mental creativity and various types of cyberloafing conduct. Andel *et al.* (2019) suggested that moderate cyberloafing can act as a coping mechanism and reduce exposure to workplace aggression.

This study links social cyberloafing with employees' social sustainability, one of the critical elements of Society 5.0, which refers to a mechanism for developing places that foster sustainable well-being and success through an awareness of the needs of people living and working in places (Woodcraft *et al.*, 2012). Society 5.0, which focuses on human well-being, has gained prominence among policymakers and scholars. Polese and Stren (2000) termed it a development that promotes a high quality of life for everyone in society, regardless of social and cultural background. This notion came from the Japanese government intending to achieve a long-term balance between the environment, people, economy, and technology (Yao *et al.*, 2024). Traditionally, techno-driven outcomes have contributed to social progress. Society 5.0 focuses on establishing a culture that gives people a sense of worth and well-being. In the same vein, Potočan *et al.* (2021) and Abbas (2025) argued that Society 5.0 strengthens the social perspective of corporate social responsibility (CSR) in addressing critical social issues in the digital era, such as comfortable living for humans, a reduction in medical costs, and automated health care. Thus, Society 5.0 prioritizes societal needs at the center of a comprehensive technological and scientific advancement approach (Figure 1).

Social sustainability is one of the critical factors that can lead to opportunities for a sustainable future (Mostafa and El-Gohary, 2014). According to Post (2014), a person's quality of life is determined by how well their competencies or lifestyle enable them to fulfill their wants, values, and objectives. Prior studies have measured social sustainability mainly

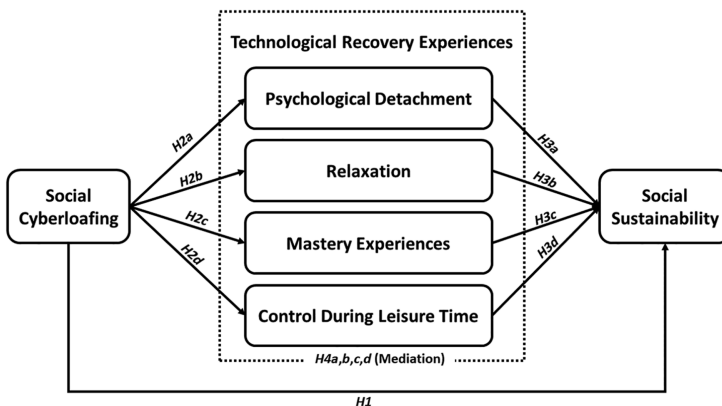

Figure 1. Research framework. Source: Figure created by authors

regarding quality of life and well-being. From the social cyberloafing perspective, workers in the modern era who are given brief periods to interact with one another online have the potential to improve health by reducing stress, increasing social connections, and so on (Corvello *et al.*, 2022). By acknowledging the advantages of social cyberloafing, we can help design workplaces that cater to employees' social needs without sacrificing productivity; this is essential in Society 5.0, which emphasizes human-centered approaches to technology (Gil-Cordero *et al.*, 2024; Kim *et al.*, 2023). Consequently, there may be new ways to improve employee health and create healthier work environments in SMEs in the digital age if we investigate the connection between social cyberloafing and social sustainability. Thus, it is postulated that:

H1. Social cyberloafing significantly and positively affects employees' social sustainability.

2.3 Social cyberloafing and recovery experiences

In the techno-driven era, recovery experiences (RE) during work promote positive outcomes by replenishing individual resources and reducing job-related tension (Sonnetag and Natter, 2004). It can be defined as an individual's perception that the activity they pursue helps restore their resources (Headrick *et al.*, 2023). Sonnetag and Fritz (2007) classified RE into four sub-variables: relaxation, mastery experiences, control over leisure time, and psychological detachment. Psychological detachment refers to an individual's disengagement from work physically and mentally (Alsuwailam and Freaney, 2024). Relaxation is generally linked to leisure activities, including physical and mental activities such as light walks and music (Trzebiatowski, 2023). Mastery experiences involve pursuing opportunities for learning outside of the work environment and experiencing challenging situations (Yeh *et al.*, 2019). Finally, control during leisure time highlights the degree to which individuals select what to do during their free time and when and how to do it (Tan *et al.*, 2024a, b).

Scholars have studied recovery experiences with various exogenous and endogenous constructs and noted mixed results. For example, Krampitz *et al.* (2023) examined the linkages between online leadership training, skills, and three recovery experiences (control of leisure time, relaxation, and detachment). They affirmed that relaxation and detachment are significantly associated with online leadership training. Arnold *et al.* (2023) examined the daily trajectories of evening recovery experiences and their role in the next-day mood in the employee context. They concluded that recovery experiences positively reshaped employees' attitudes and behavior towards colleagues and designated tasks. Majcen *et al.* (2023) linked recovery experiences with work engagement through the mediating role of emotions at work in Croatian employees. Positive emotions mediate the relationship between recovery experiences and work engagement. Specifically, positive emotions significantly enhanced work engagement when recovery was measured as developing mastery experiences, relaxation, and high control over leisure time. However, the relationship between relaxation and work engagement was found to be influenced solely by negative emotions.

Given the established link between recovery experiences and work outcomes, it is essential to consider how various work-related stressors and coping mechanisms may influence these experiences. Kariv (2008) conducted a study on Israeli entrepreneurs and stated that positive stress enhances business turnover, while negative stress hinders it; the interplay of gender with social support and role conflict amplifies the individual effects of each stressor on business turnover, while coping strategies, such as psychological detachment and relaxation, have been shown to buffer the negative effects of stress (Demirtepe-Saygılı and Metin-Orta, 2021). Bhattacharjee and Sarkar (2024) found that excessive cyberloafing can reduce work productivity and stress, which may limit its potential to serve as a recovery experience. Additionally, Zhou *et al.* (2023) suggested that cyberloafing can cause feelings of guilt or anxiety, as employees perceive time spent on non-work-related activities as a waste, which can ultimately hinder psychological detachment.

This study argues that social cyberloafing in SMEs provides employees with a temporary respite from the stressors associated with their work. Perusing social media or watching entertaining videos can offer employees a much-needed respite, allowing them to unwind and mentally detach from their work, which is crucial for overall well-being and recovery (Centobelli *et al.*, 2022). Moreover, the diverse range of online content enables individuals to participate in activities that correspond to their interests, cultivating a feeling of mastery and competence. As individuals traverse various online platforms, they may come across chances to acquire fresh skills or knowledge, which can foster a sense of achievement. Social cyberloafing allows employees to enjoy leisure time while at work, relaxing and recovering amidst their professional obligations (Gil-Cordero *et al.*, 2024). By facilitating these recovery experiences, engaging in social cyberloafing can significantly impact employees' overall well-being and mitigate the risk of burnout. This view is further supported by Tandon *et al.* (2022), who emphasized the dual role of cyberloafing in workplaces as both a potential source of distraction and a recovery tool for employees, depending on the context and extent of engagement. Thus, we postulate the following:

- H2a. Social cyberloafing is a significant positive predictor of employees' psychological detachment at work.
- H2b. Social cyberloafing is a significant positive predictor of employees' relaxation at work.
- H2c. Social cyberloafing positively relates to employees' mastery experiences at work.
- H2d. Social cyberloafing is a significant positive predictor of employees' control during leisure time at work.

2.4 Recovery experiences and social sustainability

According to ERM, putting resources into work-related duties produces stress effects, indicating resource depletion (Meijman and Mulder, 1998). To re-energize and prepare for new challenges, employees engage in activities during office downtime that differ from their job duties, referred to as below-baseline activities or recovery experiences (Sonnentag and Fritz, 2007). Sonnentag and Fritz (2007) validated the concept of recovery experiences via a four-factor framework: psychological detachment, relaxation, mastery experiences, and control over leisure time. Psychological detachment is an individual's psychological separation from work-related activities that generates a sense of separation from work (Majcen *et al.*, 2023). This separation extends physical absence during off-work hours and refraining from work responsibilities. Prior studies highlight that psychological detachment is associated with decreased feelings of depression, a next-day pleasant mood (Arnold *et al.*, 2023), leadership training (Krampitz *et al.*, 2023), reduced psychological distress, work engagement (Liu *et al.*, 2023; Majcen *et al.*, 2023), and working mothers' boundary conditions (Trzebiatowski, 2023).

In addition to psychological separation from work, relaxation is another way to cope with work-related stress. Employees can recover by relaxing during their free time, whether through intentional endeavors such as meditation or low-activation hobbies (reading a book or walking) (Sonnentag *et al.*, 2023). These hobbies do not demand any social, physical, or intellectual effort, but they are both mentally and physically beneficial (Headrick *et al.*, 2023). Relaxation has been linked to lower levels of emotional tiredness, higher levels of morning tranquility, and the ability to forecast favorable feelings at work (Majcen *et al.*, 2023). It has also been linked with online self-leadership training (Krampitz *et al.*, 2023), work engagement (Majcen *et al.*, 2023), next-day moods (Arnold *et al.*, 2023), and psychological distress.

Mastery experiences indicate educational or challenging activities outside the workplace that motivate employees and distract them from their routine work (Trzebiatowski, 2023). According to Arnold *et al.* (2023), mastery experiences do not affect next-day mood states.

However, [Majcen et al. \(2023\)](#) described mastery experiences as negatively linked with negative emotions and positively related to work engagement. Control over leisure or leisure control is another factor related to recovery experiences. It is related to people's self-directed leisure activities, which stimulate enjoyment and compensate for any powerlessness they may have experienced at work ([Majcen et al., 2023](#)). The leisure control construct stimulates workers' boundary conditions ([Trzebiatowski, 2023](#)), work engagement ([Majcen et al., 2023](#)), and online self-leadership training ([Krampitz et al., 2023](#)).

This study links employees' recovery experiences with their social sustainability. It is argued that when people can mentally distance themselves from stressors at work and participate in activities that encourage relaxation and personal growth, they feel greater control over their free time. Employees can manage their work and personal lives with enhanced power, improving well-being and job satisfaction. In addition, organizations can bolster social unity and establish a culture characterized by shared regard and comprehension by cultivating a nurturing atmosphere that promotes employees' focus on their recovery. Therefore, by acknowledging and appreciating the significance of recovery experiences, organizations can enhance the social sustainability of their workforce, ultimately resulting in better individual and organizational outcomes. Thus, the following hypotheses are proposed:

- H3a.* Psychological detachment is significantly positively related to employees' social sustainability.
- H3b.* Relaxation has a significant and positive relationship with employees' social sustainability.
- H3c.* Mastery experience is a significant positive predictor of employees' social sustainability.
- H3d.* Control during leisure is positively associated with employees' social sustainability.

Building on prior debates along with ERM, we propose a mediating effect in which employees' participation in social cyberloafing promotes social sustainability through enhanced recovery experiences. Social cyberloafing, when combined with recovery experiences such as psychological detachment and relaxation, aids in employees' mental health recovery ([Headrick et al., 2023](#)). During the COVID-19 pandemic, recovery experiences, such as psychological detachment, relaxation, mastery, and control, during leisure time, were effectively linked to physical exercise and general well-being. Thus, we suggest the following hypotheses.

- H4a.* The relationship between social cyberloafing and employees' social sustainability is positively mediated by psychological detachment.
- H4b.* Relaxation positively mediates the relationship between social cyberloafing and employees' social sustainability.
- H4c.* Mastery experience positively mediates the relationship between social cyberloafing and employees' social sustainability.
- H4d.* Control during leisure time positively mediates the relationship between social cyberloafing and employees' social sustainability.

3. Research methodology

3.1 Population and sample

An online and self-administered survey questionnaire approach was employed to collect the data. The study population comprises employees working in Turkey's manufacturing and

Table 1. Demographic statistics ($N = 254$)

Variable	Element	f	Percentage (%)
Age	20–30	85	33.47%
	31–40	110	43.32%
	41–50	49	19.31%
	≥51	10	3.9%
Gender	Male	141	55.51%
	Female	109	42.91%
	Undisclosed	04	1.5%
Education	Pre-Bachelor	19	7.47%
	Bachelor	40	15.75%
	Master	155	61.03%
	Post Master	40	15.75%
Position	Non-Managerial	98	38.58%
	Junior Manager	73	28.74%
	Middle Manager	62	24.41%
	Senior Manager	21	8.27%
Work experience	Up to 5 years	98	38.58%
	6–10 years	130	51.18%
	≥10 years	26	10.24%
Duration (time spent on the internet every day)	Up to 1 h	15	5.91%
	2–4 h	148	58.27%
	5–6 h	70	27.56%
	≥6 h	21	8.26%

Source(s): Table created by authors

services SMEs. A nonprobability convenience sampling technique was used to reach the study population. The G*Power technique was adopted to determine the sample size. Before data collection, both pretesting and pilot test steps were performed. Initially, 934 individuals were approached to share their opinions, two hundred seventy (270) of whom completed the survey, with 254 questionnaires being fully completed and retained for further analysis, for a response rate of 28.9%. The sample comprises 52% (133) male and 47.84% (121) female employees. Most respondents had a master's degree (61%), as reported in [Table 1](#).

3.2 Measures

The multi-item scales were adapted from different studies to measure social cyberloafing, recovery experiences, and social sustainability. A seven-item scale was adapted from [Wu et al. \(2020a, b\)](#) to measure social cyberloafing. The four dimensions of recovery experience were measured using sixteen items adapted from [Sonnetag and Fritz \(2007\)](#). Finally, social sustainability was measured using five items developed by [McDonald-Miszczak and Wister \(2005\)](#) and further refined by [Wu et al. \(2020a, b\)](#). All the items were measured on a 5-point Likert scale (1 = never, 5 = always).

4. Analysis and results

4.1 Descriptive statistics and common method bias

The mean value of the studied constructs ranged from 3.34 to 3.93, except for social cyberloafing, which was 4.06. The standard deviation (Std. Dev.) of all the indicators is less than 1. Finally, the kurtosis values are within acceptable limits. Common method bias (CMB), a common challenge in primary data research ([Ali and Johl, 2023](#)), occurs when a singular methodology is employed to gather data for numerous variables within a study. Using just one method can unintentionally impact the findings, resulting in an exaggerated correlation

Table 2. Descriptive statistics

Constructs	Mean	Std. dev.	Kurtosis	Skewness
Social Cyberloafing	4.06	0.92	0.53	-1.25
Psychological Detachment	3.93	0.87	-0.18	-1.14
Relaxation	3.86	0.91	-0.18	-1.12
Mastery Experiences	3.91	0.87	-0.16	-1.08
Control during leisure time	3.92	0.94	-0.20	-1.13
Social Sustainability	3.34	0.90	-0.54	-0.76

Source(s): Table created by authors

between the variables. A Harmon single-factor test was performed to examine this aspect, which indicated that the highest covariance explained by a single factor was 32.31%, less than the threshold value of 50%; thus, CMB is considered nonexistent (Podsakoff *et al.*, 2003). Table 2 presents the descriptive statistics of the study variables.

4.2 Reliability and convergent validity

For reliability statistics, Cronbach’s alpha (α) and rho_A statistics were reported with thresholds greater than or equal to 0.70 (Magno *et al.*, 2022). The average variance extracted

Table 3. Construct reliability and convergent validity

Constructs		Loadings	Reliability Cronbach’s α	rho_A	AVE
Social Cyberloafing (SC)	SC1	0.819	0.830	0.833	0.705
	SC2	0.832			
	SC3	0.827			
	SC4	0.820			
	SC5	0.831			
	SC6	0.886			
	SC7	0.858			
Recovery experiences	PD1	0.816	0.910	0.911	0.827
	PD2	0.900			
	PD3	0.821			
	PD4	0.901			
	RX1	0.903	0.831		
	RX2	0.905			
	RX3	0.814			
	RX4	0.820			
	ME1	0.913	0.894		
	ME2	0.889			
ME3	0.895				
ME4	0.903				
Social Sustainability	CLT1	0.816	0.838	0.839	0.843
	CLT2	0.810			
	CLT3	0.821			
	CLT4	0.824			
	SS1	0.904	0.894		
	SS2	0.825			
	SS3	0.910			
	SS4	0.916			
SS5	0.899				

Source(s): Table created by authors

(AVE) was examined for convergent validity. Table 3 indicates that the AVE values of all the study constructs are greater than 0.5, indicating that the study variables achieve the threshold limit of the AVE (Hair et al., 2022). Moreover, item loading statistics were also reported, and all the loadings were above the threshold value (≥ 0.70) (Hair et al., 2019).

4.3 Discriminant validity

In analyzing the measurement model, discriminant validity analyses ensure that each construct captures an independent phenomenon and remains statistically distinct (Hair et al., 2019). Typically, cross-loading and the Fornell–Larcker criterion are used for this purpose; however, they overestimate discriminant validity (Hair et al., 2019). Instead, Hair et al. (2019) advocated using the Heterotrait–Monotrait correlation ratio (HTMT) for discriminant validity analysis, which is more reliable. Ideally, the HTMT threshold value is frequently less than 0.85 for unique constructs and less than 0.90 for identical ones. However, Franke and Sarstedt (2019) proposed an acceptable cut-off value of less than 0.90 for HTMT in general. The HTMT values are shown in Table 4.

Next, the association between social cyberloafing and social sustainability (H1) was evaluated, and the structural model revealed a significant positive relationship between them, with $\beta = 0.750$, t value = 25.085, and $p < 0.05$. Next, the relationships between social cyberloafing and different constructs of recovery experience were examined. The relationship between social cyberloafing and psychological detachment (H2a) presented a positive and significant outcome, with $\beta = 0.703$, t value = 16.964, $p < 0.05$. Likewise, for relaxation (H2b), the analysis presented $\beta = 0.684$, t value = 15.294, and $p < 0.05$ findings. For mastery experience (H2c), the study presented $\beta = 0.707$, t value = 17.779, and $p < 0.05$ findings. Finally, for leisure time (H2d), social cyberloafing presented $\beta = 0.700$, t value = 16.412, and $p < 0.05$ findings. Next, the impact of recovery experiences on social sustainability was

Table 4. Discriminant validity statistics through the HTMT

Variables	(a)	(b)	(c)	(d)	(e)	(f)
SC (a)						
PD (b)	0.754					
RX (c)	0.734	0.767				
ME (d)	0.762	0.641	0.669			
CLT (e)	0.748	0.856	0.692	0.750		
SS (f)	0.797	0.714	0.878	0.855	0.879	

Source(s): Table created by authors

Table 5. Structural model and direct effect

Relation	β -value	t value	f^2	CI (2.05%–97.5%)	Decision	
H1	SC → SS	0.272	5.296	0.163	(0.172–0.372)	Supported
H2a	SC → PD	0.703	16.964	0.975	(0.621–0.779)	Supported
H2b	SC → RX	0.684	15.294	0.881	(0.590–0.769)	Supported
H2c	SC → ME	0.707	17.779	0.321	(0.627–0.778)	Supported
H2d	SC → CLT	0.700	16.412	0.251	(0.610–0.777)	Supported
H3a	PD → SS	0.534	7.694	0.163	(0.398–0.662)	Supported
H3b	RX → SS	0.285	2.409	0.028	(0.100–0.544)	Supported
H3c	ME → SS	−0.007	0.070	0.001	(−0.175–0.199)	Rejected
H3d	CLT → SS	−0.125	0.950	0.004	(−0.426–0.081)	Rejected

Source(s): Table created by authors

studied. The impact of psychological detachment on social sustainability presented (H3a) $\beta = 0.534$, t -value = 7.694, and $p < 0.05$. Likewise, relaxation (H3b) presented $\beta = 0.285$, t value = 2.409, and $p < 0.05$ values, and mastery experience (H3) presented a negative association with social sustainability, with $\beta = -0.007$, t value = 0.070, and $p = 0.944$. Similar findings regarding control over leisure time and social sustainability were observed, with $\beta = -0.125$, t value = 0.950, and $p = 0.332$. Hence, Hypotheses H2a, H2b, H2c, H2d, H3a and H3b were supported and accepted. H3c and H3d were not significant and were rejected. Table 5 presents the statistics of the research hypotheses.

4.4 Mediating analysis

Table 6 demonstrates the indirect relationship between social cyberloafing and social sustainability through recovery experiences. It highlights that psychological detachment and relaxation positively mediate the relationship between social cyberloafing and social sustainability, with $\beta = 0.375$ and $\beta = 0.195$, respectively, suggesting the acceptance of H5a and H4c. In contrast, the results for masterly experience and control during leisure time are insignificant, suggesting the rejection of H4b and H4d. The variance accounting (VAF) approach was followed to calculate the mediation type and magnitude, as shown in Table 7. According to Hair et al. (2019), a value of VAF less than 20% represents no mediation. Above 20% but below 80%, VAF represents partial mediation, and a value above 80% indicates full mediation. The VAF value indicates that psychological detachment (58%) and relaxation (42%) partially mediate the relationship between social cyberloafing and social sustainability. Finally, Figure 2 shows the PLS path model.

Table 6. Indirect effects

Relationship	β	T-statistics	CI [2.50–97.50]	p-value
SC → PD → SS	0.375	8.274	[0.277–0.469]	0.000
SC → RX → SS	0.195	2.838	[0.091–0.346]	0.007
SC → ME → SS	-0.005	0.08	[-0.097–0.190]	0.936
SC → CLT → SS	-0.088	1.148	[-0.300–0.001]	0.256

Source(s): Table created by authors

Table 7. Mediation analysis

Direct effect	Coefficient	Bootstrap 90% CI Percentile		BC	
		Lower (5%)	Upper (95%)	Lower (5%)	Upper (95%)
C'	0.272 ^{Sig}	0.186	0.356	0.187	0.357
a1	0.703 ^{Sig}	0.632	0.768	0.631	0.767
a2	0.684 ^{Sig}	0.610	0.755	0.609	0.754
b1	0.534 ^{Sig}	0.416	0.644	0.416	0.644
b2	0.285 ^{Sig}	0.130	0.518	0.111	0.499

Indirect effect	Point estimate	Percentile		BC		VAF
		Lower (5%)	Upper (95%)	Lower (5%)	Upper (95%)	
a1×b1	0.375 ^{Sig}	0.284	0.468	0.284	0.076	58%
a2×b2	0.195 ^{Sig}	0.088	0.357	0.467	0.344	42%
Total Indirect effect	0.570	0.372	0.825	0.751	0.420	

Source(s): Table created by authors

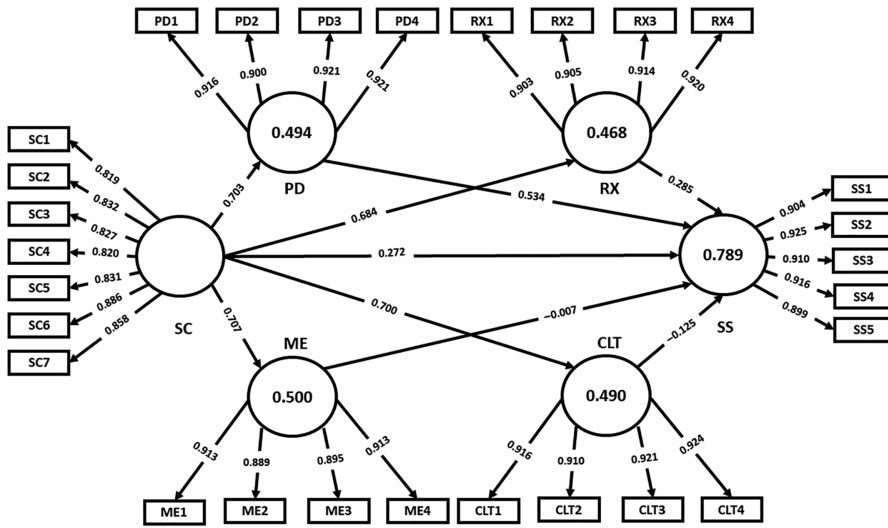

Figure 2. PLS-path model. Source: Figure created by authors

4.5 Importance performance map analysis (IPMA)

Importance–performance map analysis (IPMA), often called importance–performance matrix analysis, is used to develop an in-depth understanding of the relationships between constructs in a model. This approach goes beyond typical PLS-SEM analysis by considering the importance and performance of constructs. Importance indicates the absolute total influence of the final endogenous construct, while performance indicates the size of a latent variable’s score. In Figure 3, the vertical axis shows the performance of the endogenous variable (social sustainability), and the horizontal axis shows the level of importance. Following the approach of Leong *et al.* (2019), the study partitioned the IPMA chart into four sectors. As shown in Figure 3, social cyberloafing has the highest importance (75%) and performance above 70%,

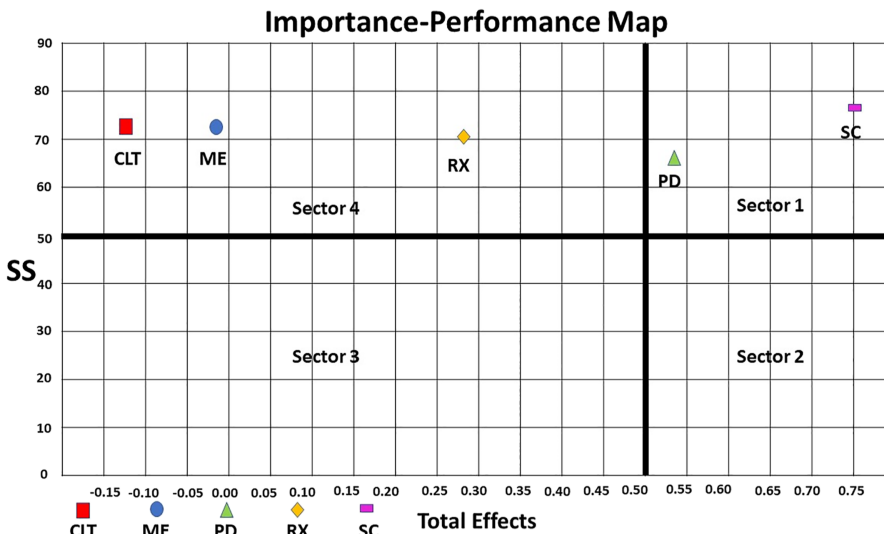

Figure 3. Importance-performance map analyses (IPMA). Source: Figure created by authors

followed by psychological detachment. Both constructs fall into sector 1. None of the factors fall into sectors 2 and 3. In sector 4, mastery experience and control during leisure are the least important in this study context. Hence, the IPMA results confirm that social cyberloafing, psychological detachment, and relaxation are stronger predictors of social sustainability.

5. Discussing the findings

The current study provides mixed results. For instance, the analysis of the relationship between social cyberloafing and social sustainability indicated a positive and significant association, leading to the acceptance of **H1** that social cyberloafing has a positive association with SME employees' social sustainability. This result is in line with [Zhang et al.'s \(2023\)](#) premise that technological advancements positively impact the personal social well-being of Chinese youth. With the ever-growing presence of technology in our lives, it is unsurprising that employees are increasingly drawn to online social interactions while on the clock. In Society 5.0, which places great importance on the fusion of technology and solutions that prioritize human well-being, social cyberloafing can be seen as a way for employees to satisfy their social needs and stay connected with their social circles. Social cyberloafing can foster employees' sense of connectedness, belonging, and social support in small firms through online social interactions, ultimately contributing to their overall social sustainability.

This study also hypothesizes that social cyberloafing positively correlates with four technological recovery experience constructs: psychological detachment, relaxation, mastery experience, and control during leisure time. The positive correlation between social cyberloafing and these recovery experiences is grounded in the broader theoretical framework of recovery theory, which posits that individuals must engage in restorative activities to mitigate work stress and maintain well-being ([Sonnentag and Fritz, 2007](#)). By positioning cyberloafing as a recovery mechanism, this study aligns with the view that digital leisure activities can restore cognitive resources, providing a reprieve from work pressures and promoting positive well-being. This finding indicates that social cyberloafing positively correlates with psychological detachment (**H2a**), which aligns with the findings of [Majcen et al. \(2023\)](#). According to [Majcen et al. \(2023\)](#), psychological elements at work contribute to Croatian employees' involvement at work. Likewise, [Gellmers and Yan \(2023\)](#) argued that the resource recovery process is positively associated with digital leisure at the workplace which further enhances employee well-being. Social cyberloafing appears to function as a means for employees to mentally disengage from their professional obligations. By disengaging from work pressures, individuals can enjoy tranquility and cognitive revitalization, positively impacting their general welfare and mental state. Social cyberloafing can help certain individuals detach psychologically; its effectiveness can differ based on personal preferences, the work environment, and individual characteristics.

Similarly, social cyberloafing presented a positive and significant association with relaxation (**H2b**), which corroborates the findings of [Krampitz et al. \(2023\)](#) and contradicts the arguments of [Majcen et al. \(2023\)](#) that relaxation does not predict employee engagement. [Acosta-Prado et al. \(2022\)](#) reported that to achieve prestress states and promote body recovery, relaxation is essential for reducing stress, and the findings of the current study suggest that social cyberloafing provides employees with a valuable opportunity for relaxation while at work. Employees can temporarily distance themselves from work pressures through social cyberloafing, providing a much-needed respite. This, in turn, creates an atmosphere that is more relaxed and conducive to productivity. Building on the work of [Demirtepe-Saygılı and Metin-Orta \(2021\)](#), it is crucial to note that the extent to which cyberloafing enhances relaxation may vary depending on the individual's coping style and the type of cyberloafing activity they engage in, emphasizing the need for a more nuanced understanding of this behavior.

The analysis of the impact of social cyberloafing on mastery experience (**H2c**) and leisure control (**H2d**) also revealed significant positive results, which aligns with the findings of [Trzebiatowski \(2023\)](#) and [Zhang et al. \(2024\)](#). For instance, [Zhang et al. \(2024\)](#) contend that

minor cyberloafing through digital technologies significantly promotes work-related factors and job satisfaction in China. These findings highlight the complex nature of workplace behavior and its outcomes. Mastery experiences occur when individuals feel a deep sense of accomplishment or competence in their tasks or roles (Majcen *et al.*, 2023). This finding implies that engaging in social cyberloafing can act as a catalyst for cultivating mastery experiences among employees, as cyberloafing is commonly perceived as a means of diverting attention or engaging in unproductive activities while at work; this concept may appear paradoxical. However, when employees engage in activities such as learning new skills or gaining professional insights through online content, social cyberloafing can act as a form of “micro-learning” that fosters personal growth and professional mastery. This is consistent with “learning through leisure” (Tan *et al.*, 2024a, b), where employees may gain new competencies without formally engaging in work-related tasks.

However, the social interactions and information exchange enabled by cyberloafing platforms can offer employees valuable chances to acquire knowledge, share insights, and cultivate new abilities. The findings suggest that engaging in online forums or discussion groups about their profession can provide employees with various viewpoints and valuable knowledge, ultimately increasing their expertise and confidence in their chosen field (Ferreira *et al.*, 2024). Likewise, the association between social cyberloafing and leisure time at work suggests that employees find these activities enjoyable or fulfilling while on the job. Instead of perceiving cyberloafing solely as a method to evade work-related stress or monotony, employees may partake in these activities to unwind and rejuvenate, enhancing their overall sense of well-being and job contentment. This reaffirms the argument that cyberloafing can serve as a beneficial coping mechanism, especially when individuals engage in activities that promote psychological recovery and professional development.

Analyzing the effects of recovery experiences on employees’ social sustainability presented mixed results. Psychological detachment and relaxation had significant positive impacts, whereas the results of mastery experience and control during leisure time were insignificant. Psychological detachment is crucial in promoting social sustainability by allowing individuals to effectively disconnect from work-related thoughts and concerns during their leisure time, aligning with Alsuwailem and Freeney’s (2024) study. This finding indicates that individuals who can disconnect from the work experience improve their social well-being, potentially because they have fewer work-related stressors that can disrupt their social interactions or relationships. Similarly, the significance of taking time to relax and unwind becomes apparent when its impact on social sustainability is considered. This finding suggests that individuals who participate in activities that restore their energy and well-being also tend to develop stronger social connections and support networks. This confirms the findings of Trzebiatowski (2023), who reported that relaxation at work plays a critical role in employees’ quality of life. On the other hand, the insignificant impact of mastery, expertise, and control during leisure time on social sustainability implies that although these factors may enhance personal happiness or contentment, they may not directly result in improved workplace social dynamics or relationships. Engaging in leisure activities that bring a sense of competence or accomplishment can significantly contribute to personal fulfillment, with a focus on individual growth rather than social interactions. Similarly, the level of control individuals have over their free time may not necessarily align with their social sustainability. In this context, Lee and Roh (2023) suggested that other factors may more significantly influence social dynamics in the workplace. Haseeb *et al.* (2019) claimed that digital technologies are vital in promoting sustainable performance among Thai SMEs.

The study also examines the mediating role of recovery experiences between social cyberloafing and social sustainability. The mediation analysis revealed that psychological detachment and relaxation partially mediated the relationship between social cyberloafing and social sustainability, confirming H4a and H4b. Brummelhuis and Bakker (2012) supported these findings and reported that creating a relaxed environment at work mediates off-job activities and next-day work engagement. Likewise, Ding *et al.* (2020) argued that recovery

experiences partially mediate the relationship between resilience and quality of life among Chinese physicians. On the other hand, mastery experiences and leisure for control play no mediating role in social cyberloafing or social sustainability; thus, H4c and H4d are rejected. To support this Gökçeşlan *et al.* (2016) claimed that addicted users of the smartphone have problems controlling their leisure time.

5.1 Contributions and implications

5.1.1 Theoretical contributions. The study's findings make multiple theoretical contributions and practical implications. Firstly, this research extends the knowledge of social cyberloafing by proving its favorable impact on social sustainability. As opposed to the traditional view that the concept of cyberloafing is deviant, the study highlights that it can enhance the social aspects of the workplace in the context of Society 5.0, which emphasizes the integration of human-machine interaction. Secondly, the study added to the knowledge on recovery experiences by emphasizing the importance of social cyberloafing. This outcome builds on earlier studies by demonstrating that social cyberloafing allows employees to mentally detach from work demands, providing a new explanation for how digital activities at work might lead to greater mental health and quality of life. Thirdly, this study challenges the claim that all constructs of recovery experiences contribute equally to social sustainability. The findings highlight that psychological detachment and relaxation improve social sustainability while other factors do not substantially impact. This distinction suggests that not all recovery attributes enhance workplace social dynamics in the digital era. Finally, the mediation results contribute to our understanding of how recovery experiences help to mediate the association between social cyberloafing and social sustainability in Society 5.0. In particular, psychological detachment and relaxation serve as essential mediators. It significantly expands the knowledge of how social cyberloafing affects social sustainability, highlighting the relevance of mental recovery processes in fostering employee health and well-being.

5.1.2 Practical implications. Apart from theoretical contributions, the study findings have fourfold practical implications for managers and policymakers. Firstly, managers should recognize that, when properly managed, social cyberloafing can positively impact employees' social sustainability, well-being, and productivity. Managers can establish an environment of psychological detachment and relaxation by providing short pauses for online social connections. This, in turn, minimizes emotional exhaustion and increases productivity. Secondly, policymakers should consider developing workplace policies to encourage the healthy utilization of social media platforms for social cyberloafing. By creating criteria for regulated digital leisure at work, managers may boost employees' mental well-being while maintaining productivity. Policies can be implemented to emphasize the positive function of technology in sustaining social relationships, which is critical in the framework of Society 5.0. Thirdly, recognizing social cyberloafing as desirable may have substantial economic and commercial implications. Employees with time to discontinue their tasks or short breaks mentally report lower stress, more engagement, and improved well-being. These benefits result in increased production and fewer truancy incidents, directly affecting the company's economic aspects. Finally, the findings should be integrated into future business leaders' courses to emphasize properly utilizing information technology in the workplace. Training courses on employee wellness, technology management, and human resource techniques may incorporate case studies on the advantages and pitfalls of social cyberloafing, enabling learners to understand how to capitalize on its benefits.

5.2 Limitations and future research

This study also has a few limitations. The study relied on self-reported data and a cross-sectional design, restricting depth and generalizability. Future studies should look into alternative data collection methodologies and larger industry samples. Furthermore, the study

concentrated on psychological detachment, mastery experience, relaxation, and control during leisure. Future studies should investigate other aspects of recovery experiences, such as physical activity, novelty, exploration, etc., and the limits of social cyberloafing consequences. Furthermore, the one-dimensional measurement of social cyberloafing may have overlooked essential elements. Future studies should take a holistic strategy to capture various internet behaviors. This study focuses solely on Turkish SMEs, ignoring enterprises situated in other regions. Future research should study this concept from various geographical perspectives. Furthermore, comparative research will be conducted between SMEs and large companies with the expectation of intriguing findings.

5.3 Conclusion

This study sheds light on the intricate role of social cyberloafing in fostering social sustainability within SMEs, emphasizing its intricate connection with technological recovery experiences. The study builds its arguments via ERM and tests the conceptual model via SEM. The research indicates that social cyberloafing positively affects employees' social sustainability. Moreover, this impact is significantly mediated by the technological recovery experiences, namely psychological detachment and relaxation. However, control during leisure and master experiences had an insignificant effect on their relationship. These findings indicate that SMEs have the potential to improve the well-being of their employees and the long-term viability of their organizations. By acknowledging the significance of social cyberloafing in detaching and relaxing mentally, SMEs can promote psychological recovery among their workforce. Hence, SMEs must consider these valuable insights when formulating workplace policies and interventions that recognize the positive aspects of social cyberloafing. It will help create an atmosphere that promotes employee rejuvenation and social sustainability.

References

- Abbas, J. (2024), "Does the nexus of corporate social responsibility and green dynamic capabilities drive firms toward green technological innovation? The moderating role of green transformational leadership", *Technological Forecasting and Social Change*, Vol. 208, 123698, doi: [10.1016/j.techfore.2024.123698](https://doi.org/10.1016/j.techfore.2024.123698).
- Abbas, J. (2025), "From corporate social responsibility to human social responsibility: a pathway for a sustainable society", *Journal of Cleaner Production*, Vol. 494, 144979, doi: [10.1016/j.jclepro.2025.144979](https://doi.org/10.1016/j.jclepro.2025.144979).
- Abbas, J., Bresciani, S., Subhani, G. and De Bernardi, P. (2025), "Nexus of ambidexterity and frugal innovation for enhanced ESG performance of entrepreneurial firms. The role of organizational capabilities", *International Entrepreneurship and Management Journal*, Vol. 21 No. 1, p. 47, doi: [10.1007/s11365-024-01062-5](https://doi.org/10.1007/s11365-024-01062-5).
- Acosta-Prado, J.C., Zárate-Torres, R.A. and Tafur-Mendoza, A.A. (2022), "Psychometric properties of the Wong and Law emotional intelligence scale in a Colombian manager sample", *Journal of Intelligence*, Vol. 10 No. 2, pp. 1-15, doi: [10.3390/jintelligence10020029](https://doi.org/10.3390/jintelligence10020029).
- Akar, I. and Karabulut Coskun, B. (2020), "Exploring the relationship between creativity and cyberloafing of prospective teachers", *Thinking Skills and Creativity*, Vol. 38, 100724, doi: [10.1016/j.tsc.2020.100724](https://doi.org/10.1016/j.tsc.2020.100724).
- Al Frijat, Y.S., Albawwat, I.E. and Elamer, A.A. (2024), "Exploring the mediating role of corporate social responsibility in the connection between board competence and corporate financial performance amidst global uncertainties", *Corporate Social Responsibility and Environmental Management*, Vol. 31 No. 2, pp. 1079-1095, doi: [10.1002/csr.2623](https://doi.org/10.1002/csr.2623).
- Ali, K. (2024), "Total quality management in manufacturing firms: current and future trends", *Foresight*, Vol. 26 No. 3, pp. 505-530, doi: [10.1108/FS-09-2023-0180](https://doi.org/10.1108/FS-09-2023-0180).
- Ali, K. and Johl, S.K. (2023), "Driving forces for industry 4.0 readiness, sustainable manufacturing practices and circular economy capabilities: does firm size matter?", *Journal of Manufacturing Technology Management*, Vol. 34 No. 5, pp. 838-871, doi: [10.1108/JMTM-07-2022-0254](https://doi.org/10.1108/JMTM-07-2022-0254).

- Alsuwailam, M. and Freaney, Y. (2024), "Motivational drivers and psychological detachment in shaping the work-home interface for Saudi women", *Career Development International*, Vol. 29 No. 2, pp. 267-285, doi: [10.1108/CDI-02-2023-0056](https://doi.org/10.1108/CDI-02-2023-0056).
- Alwadain, A., Fati, S.M., Ali, K. and Ali, R.F. (2024), "From theory to practice: an integrated TTF-UTAUT study on electric vehicle adoption behavior", in Jayasingh, S. (Ed.), *Plos One*, Vol. 19 No. 3, e0297890, doi: [10.1371/journal.pone.0297890](https://doi.org/10.1371/journal.pone.0297890).
- Andel, S.A., Kessler, S.R., Pindek, S., Kleinman, G. and Spector, P.E. (2019), "Is cyberloafing more complex than we originally thought? Cyberloafing as a coping response to workplace aggression exposure", *Computers in Human Behavior*, Vol. 101, pp. 124-130, doi: [10.1016/j.chb.2019.07.013](https://doi.org/10.1016/j.chb.2019.07.013).
- Arnold, M., Casper, A. and Sonnentag, S. (2023), "Daily trajectories of evening recovery experiences and their role for next-day mood", *Journal of Occupational Health Psychology*, Vol. 28 No. 5, pp. 291-309, doi: [10.1037/ocp0000359](https://doi.org/10.1037/ocp0000359).
- Bhattacharjee, A. and Sarkar, A. (2024), "Abusive supervision and cyberloafing: an investigation based on Stressor-Emotion-CWB theory", *Information Technology and People*, Vol. 37 No. 3, pp. 1126-1155, doi: [10.1108/ITP-05-2022-0353](https://doi.org/10.1108/ITP-05-2022-0353).
- Brummelhuis, L.L. and Bakker, A.B. (2012), "A resource perspective on the work-home interface: the work-home resources model", *American Psychologist*, Vol. 67 No. 7, pp. 545-556, doi: [10.1037/a0027974](https://doi.org/10.1037/a0027974).
- Centobelli, P., Cerchione, R., Esposito, E., Passaro, R. and Quinto, I. (2022), "The undigital behavior of innovative startups: empirical evidence and taxonomy of digital innovation strategies", *International Journal of Entrepreneurial Behavior and Research*, Vol. 28 No. 9, pp. 219-241, doi: [10.1108/IJEER-08-2021-0626](https://doi.org/10.1108/IJEER-08-2021-0626).
- Corvello, V., De Carolis, M., Verteramo, S. and Steiber, A. (2022), "The digital transformation of entrepreneurial work", *International Journal of Entrepreneurial Behavior and Research*, Vol. 28 No. 5, pp. 1167-1183, doi: [10.1108/IJEER-01-2021-0067](https://doi.org/10.1108/IJEER-01-2021-0067).
- Dabić, M., Maley, J.F., Švarc, J. and Poček, J. (2023), "Future of digital work: challenges for sustainable human resources management", *Journal of Innovation and Knowledge*, Vol. 8 No. 2, 100353, doi: [10.1016/j.jik.2023.100353](https://doi.org/10.1016/j.jik.2023.100353).
- Demirtepe-Saygılı, D. and Metin-Orta, I. (2021), "An investigation of cyberloafing in relation to coping styles and psychological symptoms in an educational setting", *Psychological Reports*, Vol. 124 No. 4, pp. 1559-1587, doi: [10.1177/0033294120950299](https://doi.org/10.1177/0033294120950299).
- Derin, N. and Gökçe, S.G. (2016), "Are cyberloafers also innovators?: a study on the relationship between cyberloafing and innovative work behavior", *Procedia - Social and Behavioral Sciences*, Vol. 235, pp. 694-700, doi: [10.1016/j.sbspro.2016.11.070](https://doi.org/10.1016/j.sbspro.2016.11.070).
- Ding, H., Yu, E. and Li, Y. (2020), "Core self-evaluation, perceived organizational support for strengths use and job performance: testing a mediation model", *Current Psychology*, doi: [10.1007/s12144-020-01029-z](https://doi.org/10.1007/s12144-020-01029-z).
- Ferreira, J.J.M., Fernandes, C.I. and Veiga, P.M. (2024), "The effects of knowledge spillovers, digital capabilities, and innovation on firm performance: a moderated mediation model", *Technological Forecasting and Social Change*, Vol. 200, 123086, doi: [10.1016/j.techfore.2023.123086](https://doi.org/10.1016/j.techfore.2023.123086).
- Figueroa, D., Yamazaki, R., Nishio, S., Maalouly, E., Nagata, Y., Satake, Y., Yamakawa, M., Suzuki, M., Kanemoto, H., Ikeda, M. and Ishiguro, H. (2023), "Social robot for older adults with cognitive decline: a preliminary trial", *Frontiers in Robotics and AI*, Vol. 10, 1213705, doi: [10.3389/frobt.2023.1213705](https://doi.org/10.3389/frobt.2023.1213705).
- Franke, G. and Sarstedt, M. (2019), "Heuristics versus statistics in discriminant validity testing: a comparison of four procedures", *Internet Research*, Vol. 29 No. 3, pp. 430-447, doi: [10.1108/IntR-12-2017-0515](https://doi.org/10.1108/IntR-12-2017-0515).
- Gellmers, J. and Yan, N. (2023), "Digital leisure engagement and positive outcomes in the workplace: a systematic literature review", *International Journal of Environmental Research and Public Health*, Vol. 20 No. 2, p. 1014, doi: [10.3390/ijerph20021014](https://doi.org/10.3390/ijerph20021014).

- Gil-Cordero, E., Maldonado-López, B., Ledesma-Chaves, P. and García-Guzmán, A. (2024), "Do small- and medium-sized companies intend to use the metaverse as part of their strategy? A behavioral intention analysis", *International Journal of Entrepreneurial Behavior and Research*, Vol. 30 Nos 2/3, pp. 421-449, doi: [10.1108/IJEER-09-2022-0816](https://doi.org/10.1108/IJEER-09-2022-0816).
- Hair, J.F., Sarstedt, M. and Ringle, C.M. (2019), "Rethinking some of the rethinking of partial least squares", *European Journal of Marketing*, Vol. 53 No. 4, pp. 566-584, doi: [10.1108/EJM-10-2018-0665](https://doi.org/10.1108/EJM-10-2018-0665).
- Gökçearsan, Ş., Mumcu, F.K., Haşlamam, T. and Çevik, Y.D. (2016), "Modelling smartphone addiction: The role of smartphone usage, self-regulation, general self-efficacy and cyberloafing in university students", *Computers in Human Behavior*, Vol. 63, pp. 639-649, doi: [10.1016/j.chb.2016.05.091](https://doi.org/10.1016/j.chb.2016.05.091).
- Hair, J.F. Jr, Hult, G.T.M., Ringle, C.M. and Sarstedt, M. (2022), *A Primer on Partial Least Squares Structural Equation Modeling (PLS-SEM)*, 3rd ed., SAGE Publications.
- Haseeb, M., Hussain, H.I., Slusarczyk, B. and Jermsittiparsert, K. (2019), "Industry 4.0: A solution towards technology challenges of sustainable business performance", *Social Sciences*, Vol. 8 No. 5, p. 154.
- Headrick, L., Newman, D.A., Park, Y.A. and Liang, Y. (2023), "Recovery experiences for work and health outcomes: a meta-analysis and recovery-engagement-exhaustion model", *Journal of Business and Psychology*, Vol. 38 No. 4, pp. 821-864, doi: [10.1007/s10869-022-09821-3](https://doi.org/10.1007/s10869-022-09821-3).
- Herhausen, D., Ludwig, S., Wunderlich, N.V., Grewal, D. and Schoegel, M. (2023), "Complaint de-escalation strategies on social media", *Journal of Marketing*, Vol. 87 No. 2, pp. 210-231, doi: [10.1177/00222429221119977](https://doi.org/10.1177/00222429221119977).
- Hu, Y., Chen, Y. and Ye, M. (2023), "Eager to belong: social cyberloafing as a coping response to workplace ostracism", *Current Psychology*, Vol. 42 No. 4, pp. 3372-3381, doi: [10.1007/s12144-021-01690-y](https://doi.org/10.1007/s12144-021-01690-y).
- Kanwal, N., Bin Isha, A.S.N. and Ali, K. (2024), "New ways of working: a comparative empirical analysis appertaining to health and well-being and psychosocial hazards", *Technology Analysis and Strategic Management*, Vol. ahead-of-print No. ahead-of-print, pp. 1-14, doi: [10.1080/09537325.2024.2306643](https://doi.org/10.1080/09537325.2024.2306643).
- Kariv, D. (2008), "The relationship between stress and business performance among men and women entrepreneurs", *Journal of Small Business and Entrepreneurship*, Vol. 21 No. 4, pp. 449-476, doi: [10.1080/08276331.2008.10593435](https://doi.org/10.1080/08276331.2008.10593435).
- Kemp, S. (2023), "Digital 2023: Global overview report", available at: <https://datareportal.com/reports/digital-2023-global-overview-report>
- Kim, H., Abbas, J., Haq, M.Z.U., Lee, J.H. and Hwang, J. (2023), "Differences between robot servers and human servers in brand modernity, brand love, and behavioral intentions in the restaurant industry", *Asia Pacific Journal of Marketing and Logistics*, Vol. 35 No. 7, pp. 1774-1788, doi: [10.1108/APJML-03-2022-0214](https://doi.org/10.1108/APJML-03-2022-0214).
- Koay, K.Y. and Lai, C.H.Y. (2023), "Workplace ostracism and cyberloafing: a social cognitive perspective", *Management Research Review*, Vol. 46 No. 12, pp. 1769-1782, doi: [10.1108/MRR-07-2022-0490](https://doi.org/10.1108/MRR-07-2022-0490).
- Korzynski, P. and Protsiuk, O. (2024), "What leads to cyberloafing: the empirical study of workload, self-efficacy, time management skills, and mediating effect of job satisfaction", *Behaviour and Information Technology*, Vol. 43 No. 1, pp. 200-211, doi: [10.1080/0144929X.2022.2159525](https://doi.org/10.1080/0144929X.2022.2159525).
- Krampitz, J., Tenschert, J., Furtner, M., Simon, J. and Glaser, J. (2023), "Effectiveness of online self-leadership training on leaders' self-leadership skills and recovery experiences", *Journal of Workplace Learning*, Vol. 35 No. 9, pp. 66-85, doi: [10.1108/JWL-10-2022-0125](https://doi.org/10.1108/JWL-10-2022-0125).
- Lee, M.J. and Roh, T. (2023), "Unpacking the sustainable performance in the business ecosystem: coopetition strategy, open innovation and digitalization capability", *Journal of Cleaner Production*, Vol. 412, 137433, doi: [10.1016/j.jclepro.2023.137433](https://doi.org/10.1016/j.jclepro.2023.137433).

- Leong, R.L.F., Tan, D.J., Ong, J.L., Lo, J.C., Lee, X.K., Chee, N.I.Y.N. and Chee, M.W.L. (2019), "The effects of sleep on prospective memory: a systematic review and meta-analysis", *Sleep Medicine* Vol. 47, pp. 18-27, doi: [10.1016/j.smrv.2019.05.006](https://doi.org/10.1016/j.smrv.2019.05.006).
- Lim, V.K.G. (2002), "The IT way of loafing on the job: cyberloafing, neutralizing and organizational justice", *Journal of Organizational Behavior*, Vol. 23 No. 5, pp. 675-694, doi: [10.1002/job.161](https://doi.org/10.1002/job.161).
- Lim, V.K.G. and Teo, T.S.H. (2024), "Cyberloafing: a review and research agenda", *Applied Psychology*, Vol. 73 No. 1, pp. 441-484, doi: [10.1111/apps.12452](https://doi.org/10.1111/apps.12452).
- Liu, Y.D., Chung, H.F., Zhang, Z.J. and Wu, M. (2023), "When and how digital platforms empower professional services firms: an agility perspective", *Journal of Service Theory and Practice*, Vol. 33 No. 2, pp. 149-168, doi: [10.1108/JSTP-04-2022-0092](https://doi.org/10.1108/JSTP-04-2022-0092).
- Ma, L., Zhang, X. and Yu, P. (2023), "Enterprise social media usage and social cyberloafing: an empirical investigation using the JD-R model", *Internet Research*, Vol. 34 No. 3, pp. 939-959, doi: [10.1108/INTR-04-2021-0239](https://doi.org/10.1108/INTR-04-2021-0239).
- Magno, F., Cassia, F. and Ringle, C.M. (2022), "A brief review of partial least squares structural equation modeling (PLS-SEM) use in quality management studies", *The TQM Journal*, Vol. 36 No. 5, pp. 1242-1251, doi: [10.1108/TQM-06-2022-0197](https://doi.org/10.1108/TQM-06-2022-0197).
- Majcen, J., Tonkovic-Grabovac, M. and Cernja-Rajter, I. (2023), "Recovery experiences and work engagement: the role of emotions at work", *Psihologija*, Vol. 56 No. 3, pp. 305-322, doi: [10.2298/PSI210721017M](https://doi.org/10.2298/PSI210721017M).
- Mao, J., Zhao, Y., Yang, S., Li, R.Y.M. and Abbas, J. (2022), "Intelligent transformation and customer concentration", *Journal of Organizational and End User Computing (JOEUC)*, Vol. 35 No. 2, pp. 1-15, doi: [10.4018/JOEUC.333470](https://doi.org/10.4018/JOEUC.333470).
- McDonald-Miszczak, L. and Wister, A.V. (2005), "Predicting self-care behaviors among older adults coping with arthritis: a cross-sectional and 1-Year longitudinal comparative analysis", *Journal of Aging and Health*, Vol. 17 No. 6, pp. 836-857, doi: [10.1177/0898264305280984](https://doi.org/10.1177/0898264305280984).
- Meijman, T.F. and Mulder, G. (1998), "Psychological aspects of workload", in *A Handbook of Work and Organizational Psychology*, 1st ed., Taylor & Francis.
- Mostafa, M.A. and El-Gohary, N.M. (2014), "Stakeholder-sensitive social welfare-oriented benefit analysis for sustainable infrastructure project development", *Journal of Construction Engineering and Management*, Vol. 140 No. 9, 04014038, doi: [10.1061/\(ASCE\)CO.1943-7862.0000788](https://doi.org/10.1061/(ASCE)CO.1943-7862.0000788).
- Ohana, M., Murtaza, G., Haq, I.U., Al-Shatti, E. and Chi, Z. (2024), "Why and when can CSR toward employees lead to cyberloafing? The role of workplace boredom and moral disengagement", *Journal of Business Ethics*, Vol. 189 No. 1, pp. 133-148, doi: [10.1007/s10551-023-05358-4](https://doi.org/10.1007/s10551-023-05358-4).
- O'Neill, T.A., Hambley, L.A. and Bercovich, A. (2014), "Prediction of cyberslacking when employees are working away from the office", *Computers in Human Behavior*, Vol. 34, pp. 291-298, doi: [10.1016/j.chb.2014.02.015](https://doi.org/10.1016/j.chb.2014.02.015).
- Podsakoff, P.M., MacKenzie, S.B., Lee, J.-Y. and Podsakoff, N.P. (2003), "Common method biases in behavioral research: a critical review of the literature and recommended remedies", *Journal of Applied Psychology*, Vol. 88 No. 5, pp. 879-903, doi: [10.1037/0021-9010.88.5.879](https://doi.org/10.1037/0021-9010.88.5.879).
- Polese, M. and Stren, R. (Eds) (2000), *The Social Sustainability of Cities: Diversity and the Management of Change*, University of Toronto Press, doi: [10.3138/9781442682399](https://doi.org/10.3138/9781442682399).
- Post, M. (2014), "Definitions of quality of life: what has happened and how to move on", *Topics in Spinal Cord Injury Rehabilitation*, Vol. 20 No. 3, pp. 167-180, doi: [10.1310/sci2003-167](https://doi.org/10.1310/sci2003-167).
- Potočan, V., Mulej, M. and Nedelko, Z. (2021), "Society 5.0: balancing of industry 4.0, economic advancement and social problems", *Kybernetes*, Vol. 50 No. 3, pp. 794-811, doi: [10.1108/K-12-2019-0858](https://doi.org/10.1108/K-12-2019-0858).
- She, Z. and Li, Q. (2023), "When too little or too much hurts: evidence for a curvilinear relationship between cyberloafing and task performance in public organizations", *Journal of Business Ethics*, Vol. 183 No. 4, pp. 1141-1158, doi: [10.1007/s10551-022-05038-9](https://doi.org/10.1007/s10551-022-05038-9).

- Sonnentag, S. and Fritz, C. (2007), "The recovery experience questionnaire: development and validation of a measure for assessing recuperation and unwinding from work", *Journal of Occupational Health Psychology*, Vol. 12 No. 3, pp. 204-221, doi: [10.1037/1076-8998.12.3.204](https://doi.org/10.1037/1076-8998.12.3.204).
- Sonnentag, S. and Natter, E. (2004), "Flight attendants' daily recovery from work: is there no place like home?", *International Journal of Stress Management*, Vol. 11 No. 4, pp. 366-391, doi: [10.1037/1072-5245.11.4.366](https://doi.org/10.1037/1072-5245.11.4.366).
- Sonnentag, S., Tay, L. and Neshor Shoshan, H. (2023), "A review on health and well-being at work: more than stressors and strains", *Personnel Psychology*, Vol. 76 No. 2, pp. 473-510, doi: [10.1111/peps.12572](https://doi.org/10.1111/peps.12572).
- Statista (2024), "Most popular social networks worldwide as of April 2024, ranked by number of monthly active users", Most Popular Social Networks Worldwide as of April 2024, Ranked by Number of Monthly Active Users, available at: <https://www.statista.com/statistics/272014/global-social-networks-ranked-by-number-of-users/>
- Švarc, J. and Dabić, M. (2023), "Are the 'Guys who Play Games' shaping our economic future? The Croatian economy's potential for digital transformation", in Dabić, M. and Kraus, S. (Eds), *De Gruyter Handbook of SME Entrepreneurship*, De Gruyter, Berlin, Boston, 2024, pp. 383-404, doi: [10.1515/9783110747652-018](https://doi.org/10.1515/9783110747652-018).
- Švarc, J., Dabić, M. and Tekavčić, M. (2024), "Controversies surrounding digitalization: discussions in four key domains", in *Digital Entrepreneurship in Science, Technology and Innovation*, Edward Elgar Publishing, pp. 353-372.
- Tan, M.Y.N., Ni, Z., Liu, A.S.H. and Shorey, S. (2024a), "The influence of social media on student nurses: a systematic mixed-studies review", *Nurse Education Today*, Vol. 132, 106000, doi: [10.1016/j.nedt.2023.106000](https://doi.org/10.1016/j.nedt.2023.106000).
- Tan, Z., Yan, S., Xia, Q. and Zhang, Y. (2024b), "The relationship between servant leadership and cyberloafing: an investigation of meaningful work versus citizenship pressure", *European Journal of Work and Organizational Psychology*, Vol. 33 No. 4, pp. 1-16, doi: [10.1080/1359432X.2024.2331787](https://doi.org/10.1080/1359432X.2024.2331787).
- Tandon, A., Kaur, P., Ruparel, N., Islam, J.U. and Dhir, A. (2022), "Cyberloafing and cyberslacking in the workplace: systematic literature review of past achievements and future promises", *Internet Research*, Vol. 32 No. 1, pp. 55-89, doi: [10.1108/INTR-06-2020-0332](https://doi.org/10.1108/INTR-06-2020-0332).
- Trzebiatowski, T. (2023), "A key to recovery for working mothers? Psychological detachment and the roles of relaxation, mastery and control on boundary violations", *Equality, Diversity and Inclusion: An International Journal*, Vol. 43 No. 1, pp. 132-152, doi: [10.1108/EDI-11-2022-0305](https://doi.org/10.1108/EDI-11-2022-0305).
- Tsai, H.-Y. (2023), "Do you feel like being proactive day? How daily cyberloafing influences creativity and proactive behavior: the moderating roles of work environment", *Computers in Human Behavior*, Vol. 138, 107470, doi: [10.1016/j.chb.2022.107470](https://doi.org/10.1016/j.chb.2022.107470).
- Woodcraft, S., Bacon, N., Caistor-Arendar, L. and Hackett, T. (2012), "Design for social sustainability", *Social Life*, pp. 1-58.
- Wu, J., Mei, W., Liu, L. and Ugrin, J.C. (2020a), "The bright and dark sides of social cyberloafing: effects on employee mental health in China", *Journal of Business Research*, Vol. 112, pp. 56-64, doi: [10.1016/j.jbusres.2020.02.043](https://doi.org/10.1016/j.jbusres.2020.02.043).
- Wu, J., Mei, W., Ugrin, J., Liu, L. and Wang, F. (2020b), "Curvilinear performance effects of social cyberloafing out of class: the mediating role as a recovery experience", *Information Technology and People*, Vol. 34 No. 2, pp. 581-598, doi: [10.1108/ITP-03-2019-0105](https://doi.org/10.1108/ITP-03-2019-0105).
- Yang, H., Lin, Z., Chen, X. and Peng, J. (2023), "Workplace loneliness, ego depletion and cyberloafing: can leader problem-focused interpersonal emotion management help?", *Internet Research*, Vol. 33 No. 4, pp. 1473-1494, doi: [10.1108/INTR-01-2021-0007](https://doi.org/10.1108/INTR-01-2021-0007).
- Yao, X., Ma, N., Zhang, J., Wang, K., Yang, E. and Faccio, M. (2024), "Enhancing wisdom manufacturing as industrial metaverse for industry and society 5.0", *Journal of Intelligent Manufacturing*, Vol. 35 No. 1, pp. 235-255, doi: [10.1007/s10845-022-02027-7](https://doi.org/10.1007/s10845-022-02027-7).

- Yeh, Y., Chen, S.-Y., Rega, E.M. and Lin, C.-S. (2019), "Mindful learning experience facilitates mastery experience through heightened flow and self-efficacy in game-based creativity learning", *Frontiers in Psychology*, Vol. 10, p. 1593, doi: [10.3389/fpsyg.2019.01593](https://doi.org/10.3389/fpsyg.2019.01593).
- Yu, T., Abbas, J., Rizvi, R.A. and Najam, H. (2024), "Role of environment-driven CSR, green servant leadership, and green dynamic capabilities in firm green innovation: evidence from manufacturing industry", *Environment, Development and Sustainability*, Vol. ahead-of-print No. ahead-of-print, doi: [10.1007/s10668-024-05201-4](https://doi.org/10.1007/s10668-024-05201-4).
- Zhang, X., Guo, H., Ma, L. and Zhang, G. (2024), "Minor and serious cyberloafing in the workplace: antecedents and effects on job satisfaction", *Behaviour and Information Technology*, Vol. 44 No. 2, pp. 1-20, doi: [10.1080/0144929X.2024.2319099](https://doi.org/10.1080/0144929X.2024.2319099).
- Zhang, J., Yu, H., Yang, Y. and Ma, Y. (2023), "Unintended influence of leader forgiveness: increased employee cyberloafing", *Management Decision*, Vol. 62 No. 1, pp. 107-128, doi: [10.1108/MD-10-2022-1426](https://doi.org/10.1108/MD-10-2022-1426).
- Zhou, Y., Chen, P., Liu, Q. and Wang, T. (2023), "More haste, less speed: leader bottom-line mentality and employee counter-productive social cyberloafing", *Journal of Managerial Psychology*, Vol. 38 No. 8, pp. 643-656, doi: [10.1108/JMP-02-2023-0078](https://doi.org/10.1108/JMP-02-2023-0078).

About the authors



Dr Jawad Abbas holds a Ph.D. in Innovation and Knowledge Management. He actively researches topics relating to strategic management, knowledge management, innovation management, sustainable development, etc. He has authored more than five dozen research articles in world-leading journals. His studies are prevalent among scholars, placing him among the most cited researchers in innovation. He is also associated with multiple journals for editorial activities and serves as the Head of Research at the Business School, University of Central Punjab.



Marina Dabic is a full Professor of Entrepreneurship and International Business at the University of Zagreb, Faculty of Economics and Business, Croatia and University of Dubrovnik, Croatia and University of Ljubljana School of Economics and Business, Slovenia, and Adjunct professor at ICN Business School France. According to the Stanford list, since 2002 she has been listed among 2% of scientists in business and management. She is editor in chief of *Technology in Society*, an Associate Editor of *Technological Forecasting and Social Change*, as well as Strategic change. She is also the Senior Department Editor of *IEEE Transactions on Engineering Management*. She has published over 250 papers in premier international journals, edited or co-edited several books. She is member of the panel of prestige European research council (ERC), FWO Flanders, Finish Research council and evaluator for Horizon Europe grants. Marina Dabic is the corresponding author and can be contacted at: mdabic@efzg.hr



Tilo Halaszovich is an associate professor in the Marketing Department at ICN, Nancy France He is also an affiliated professor of international management at Constructor University Bremen (formerly Jacobs University Bremen). He holds a master's degree in management science from the Technical University of Aachen (RWTH Aachen, Germany), and obtained his doctorate (rer. pol.) from the University of Bremen. His research focuses on competitiveness of firms in developing countries, with a special focus on Sub-Saharan Africa, institutional distance, and the role of technology and entrepreneurship in international business. He is a senior editor of the *European Journal of International Management* and serves on the board of the *European International Business Academy (EIBA)*. He has published in leading journals, including *Journal of Business Research*, *International Business Review* and *European Journal of International Management*.