

Discussion.

Mr. DOUGLASS called attention to a fac-simile of the lamp latterly exhibited at Smeaton's Tower, and to another of the lamps used at the new Eddystone Lighthouse. Mr. Douglass.

Captain SYDNEY WEBB, Deputy-Master of the Trinity House, said he had been much interested in listening to the Paper, supplemented as it had been by excellent diagrams, enabling the members almost to follow step by step the very difficult undertaking that had been described. The Elder Brethren of the Trinity House were sorry to be compelled to face the question of the stability of Smeaton's tower; there had always been such a halo of romance surrounding it that it seemed a kind of sacrilege to demolish it. He was sure, however, that the members would agree with him that the present tower was a fitting successor to that of Smeaton's, and that in it the country had a lighthouse which, both as to construction and the power of its light, was of its kind second to none in the world. The new light was equal to 159,600 candles, as compared with 67, which was the power of Smeaton's original chandelier light, the cost per hour being about the same. The Elder Brethren were much gratified that the work had been so successfully accomplished. It was well known that great personal as well as moral courage was required in carrying out works of this nature, and although the Author had recorded the fact of its having been completed without loss of life or limb, he had said nothing of his own personal disaster when superintending the demolition of the old tower. When he was engaged in the work at a height of 70 feet, a portion of a chain guy of the sheers gave way, and striking him, hurled him from the tower to the rocks below. All his messmates thought that he must have been annihilated by falling on the rock, but at that moment a wave rose over the rock, and he fell on his side in about 3 feet depth of water, and was carried by the receding wave into deep water, where he struck out and was saved. Mr. Douglass came from a fine old stock. Captain Webb remembered his grandfather at the Bishop Rock Lighthouse when he erected it; and if his advice had been followed it would not have been necessary to strengthen the tower, as they were now doing, under his grandson's superintendence. Captain Sydney Webb.

Mr. G. WELLS OWEN noticed the fact that, whereas in 1696 Mr. Owen Winstanley erected the lighthouse represented in one of the

Mr. Owen. drawings, and in 1706 engineers had not arrived at the true lines on which to erect lighthouses, Smeaton in 1755 had discovered the correct principle of construction, which, as might be seen from the lines of the new lighthouse, had not yet been improved upon. He wished to ask the Author what effect the vertical base had had upon the action of the waves? It was stated in the Paper that in the case of Smeaton's lighthouse the waves rose rapidly until they struck the lantern. That, no doubt, would not be the case at the new lighthouse, but the question had occurred to him, whether the waves rising in the way described, would not ward off from the lighthouse the effect of the stroke of the water.

Mr. Redman. Mr. J. B. REDMAN was struck with the modesty of the Paper, descriptive of so grand and magnificent a work of engineering. All were familiar with the romance attendant upon the site in question. There had been three stages. First, Winstanley's lighthouse, like a Chinese pagoda stuck upon a rock, where the author, in his desire that it might be subjected to the most cruel gale that ever blew, experienced the fate he courted. Next, Rudyerd's tower, a combination of timber and stone, approximating somewhat in section to the outline of its successor, stood the fury of the sea for many years, and succumbed to fire. With regard to Smeaton's tower he thought it would be admitted that the Paper was a tribute to the remarkable genius of one of the greatest masters of their craft, more especially considering how limited were the advantages he possessed compared with those of his successors of the present day, not only in regard to education and training, but as respected improved mechanical appliances such as those which Sir James Douglass had so ingeniously adapted to the erection of an isolated structure in the sea. There were three marked differences between the present lighthouse and its predecessor to which he desired to direct attention. In the first place, the tower was so much greater in elevation and in cubic capacity, that its statical resistance to the sea must be enormously greater than in Smeaton's. Smeaton's tower stood upon the summit of the rock, and no doubt the site had been selected as being that where the greatest number of hours' work could be accomplished in one tide. There was a kind of recession or cavern under the base, and one of Sir James Douglass's predecessors, Mr. James Cooper, who afterwards became a partner with Messrs. Walker and Burges, was employed in supervising a gang of men in filling it in with solid masonry. On one occasion, in comparatively calm weather, a great undulation rose

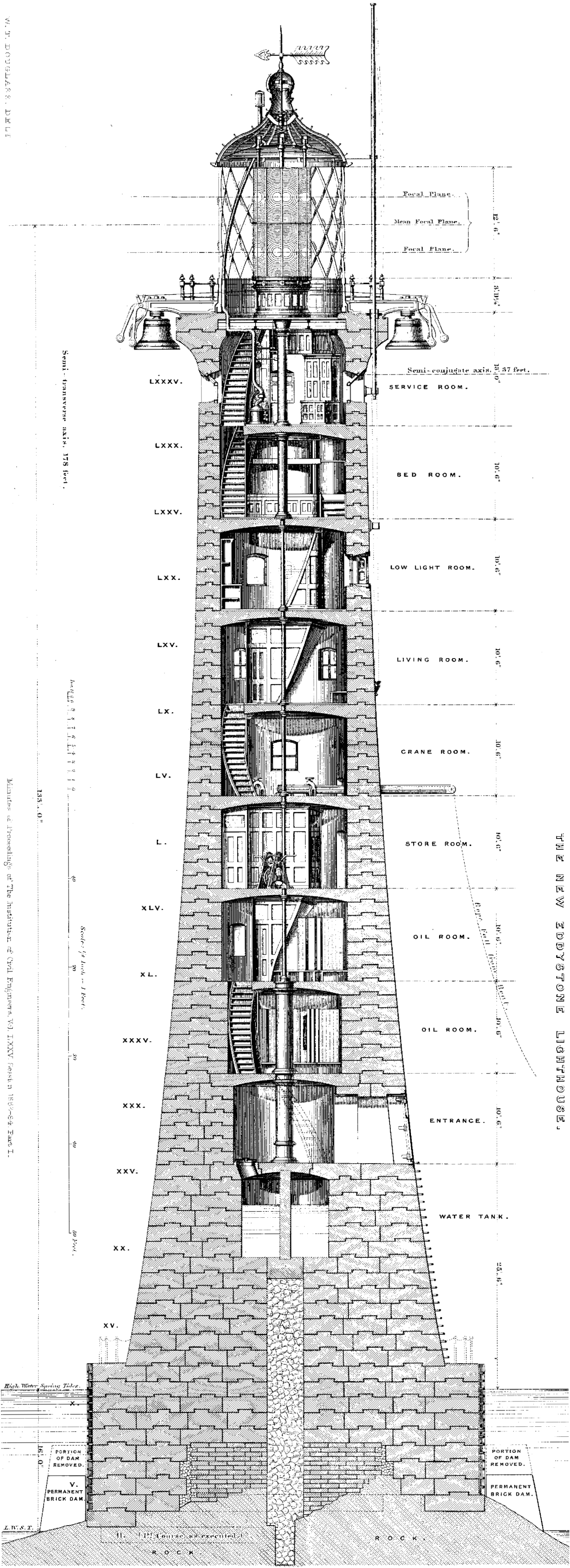

THE NEW EDDYSTONE LIGHTHOUSE.

SECTION ON LINE A. A.

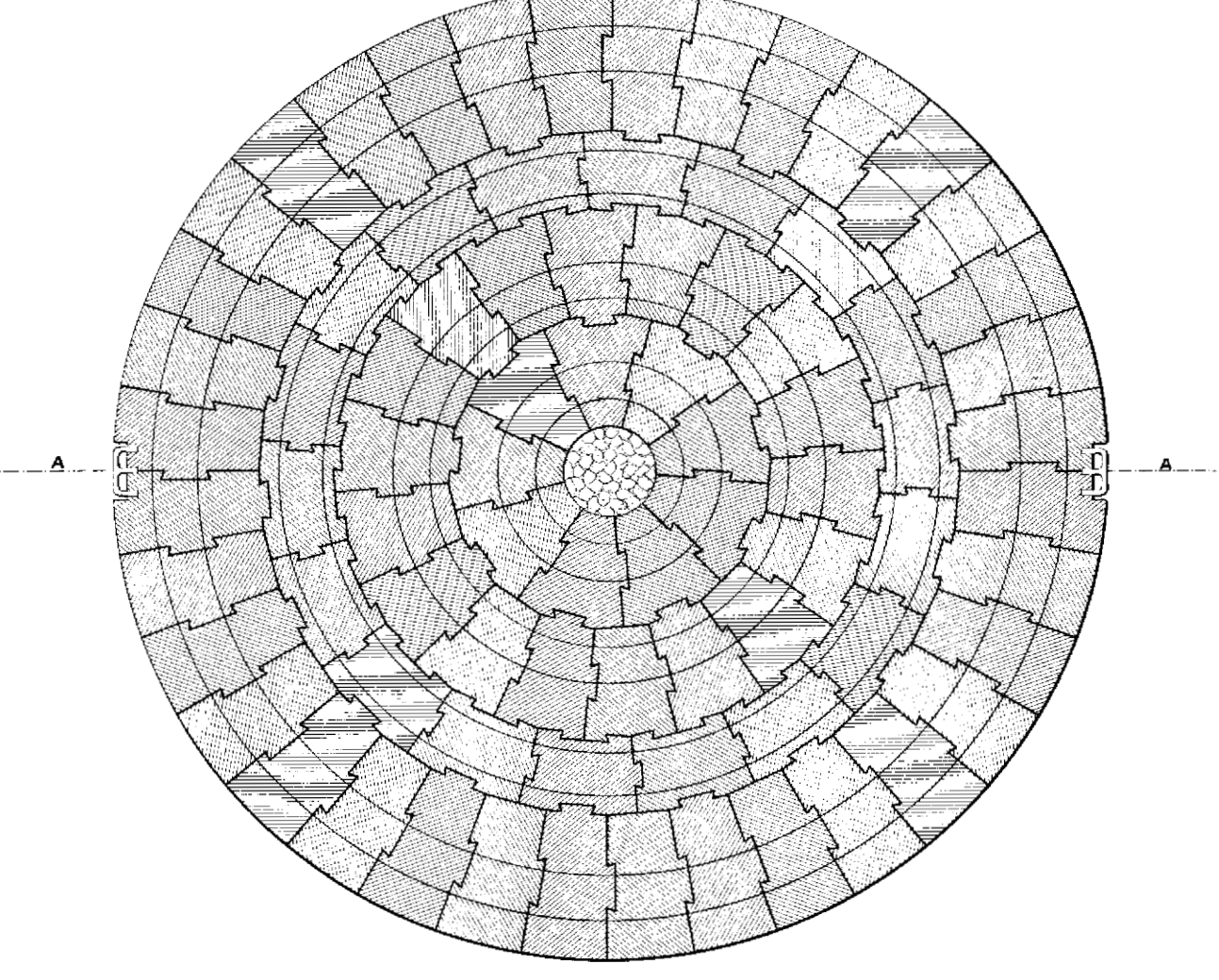

PLATE 2.

entirely over the surface of the rock, and submerged the entire party. He believed they were all saved except one mason, who was drowned. The next point of divergence was the circular platform which Sir James Douglass had constructed, on the same principle as that which he had adopted in the case of the Basses Lighthouses, the curvilinear outline commencing at the level of high-water, instead of from the base, at the rock surface. No doubt that had the power of checking the rising water and its clinging to the tower, which was one of the defects of the old structure. The water ran up the tower and fell in a cascade over the lantern, completely obscuring the light—a difficulty which had been clearly surmounted in the present tower. A somewhat similar system had been adopted at the Menai Lighthouse in the level off-set courses of its base. The next point of difference was in the dowelling, which had been already described by Sir James Douglass in his description of the Bishop Rock. That system was invented by an old colleague of Mr. Redman's, the grandfather of the Author of the Paper, and it was no doubt an improvement upon the system of joggling and dovetailing adopted by Smeaton, which no one would now think of using. His courses were so worked that no one stone could be taken out without disturbing the adjoining stones. In fact it was one homogeneous mass, but very like a Chinese puzzle. The form introduced by the elder Douglass was more simple, but Smeaton's system of joggling and vertical connection by iron rendered him to a certain extent independent of the cement now used. The Douglass system, combined with the Portland cement of the present day, formed the most perfect mass. He should like to ask whether the large slabs of rock exfoliated from the windward surface were really the result of the leverage of the stroke of the sea upon the tower, causing the uprising of that mass of rock, or whether the occurrence would not have happened from constantly repeated wave impact if there had been no lighthouse upon the summit.

Mr. MICHAEL BEAZELEY could supplement Mr. Redman's account of the differences between the two structures by reference to the difference between the thickness of the two sets of walls. It would be observed in the design for the present lighthouse that a thickness had been adopted for the walls of the entrance chamber of 8 feet 6 inches, and a thickness of the top under the cornice of 2 feet 3 inches: the latter being the same as at the Wolf and the Longships. The thinnest part of the top of the walls of the new Eddystone was 2 feet 3 inches, whereas the thickest part of the walls

Mr. Beazeley. in Smeaton's tower was only 2 feet. If he remembered rightly, the curve was so slight in Smeaton's tower that, whilst the thickness of the walls below was 2 feet, the thickness of the part under the cornice was only 18 inches. It was curious to observe that the level of the solid parts in the two lighthouses were almost identical. A vast advantage had been gained by the increase of height in the new structure over the old one. Even putting out of sight the benefit derived from the circular base adopted by Sir James Douglass, he fancied it was almost impossible, at the increased height, for any water except spray to go over the lantern. There was an absence, however, in the new Eddystone, of the off-set courses customary in rock-lights ever since they were adopted by Mr. Walker at the Menai;¹ and Mr. Beazeley would like to ask Sir James Douglass whether there was any special reason for their discontinuance in the present structure. He believed they were originally adopted to break the force of the waves, and to prevent them running up the tower; also as an effectual water-stop to the lower beds, and to prevent the feathering away of the lower beds of the stone at the bottom of the curve. He could not help expressing his great admiration at the magnificence of the work, and the successful way in which it had been carried out without accident. With regard to lighthouses in China, he might mention that it had not been found necessary to erect them on rocks. In southern China, with which he was most familiar, having the charge of the lighthouses there, he scarcely knew any rock which required a lighthouse. All the outlying dangers were comparatively large islands, and those were nearly all lighted. The only lighthouse on the mainland with which he had been concerned was at Breaker Point. That was a wrought-iron tower, designed and prepared by Sir William Armstrong, and it was of a very novel description—a narrow cylinder of wrought iron stayed with stay-bars or rigging. There were several cast-iron towers (made in England and France), and of the remainder some were built of stone and others of brick with stone dressings. At Amoy a most excellent quality of brick was made, of which almost all the dwellings were constructed. The illuminating apparatus of the lighthouses in China was entirely dioptric, with one exception—at Chefoo, where it was catoptric. The greater number of lights of the first order in China were in the southern district, and many congregated in a small area.

¹ Minutes of Proceedings Inst. C.E., vol. ii., p. 122.

Dr. J. H. GLADSTONE said he had of old taken great interest in the subject, and he had listened with great pleasure to Mr. Douglass's clear and interesting account of the modern improvements introduced in the new lighthouse. One of those improvements, which appeared to him to be a very great one, was the substitution of a flashing for a fixed light. Fixed lights were, perhaps, at one time all that could be desired; but now that there were so many fixed lights, and such bright lights in the vessels passing, it was necessary that each should indicate what light it really was; and that was obtained by the flashing apparatus described. He was glad that the periods were short. In the old revolving lights the periods were generally half a minute, or a whole minute, and frequently two minutes. That, especially during bad weather, was often a source of anxious perplexity to the mariner rather than an addition to his knowledge. The flashing light also was much brighter than a fixed light. In the case of a fixed light the rays were sent in a horizontal plane over the surface of the sea, but in the case of the flashing light not merely was that done, but they were gathered up into a powerful narrow beam which could penetrate to a great distance. That which previously illuminated, say 90° or 60° horizontally, was thus condensed within perhaps 5° . Another great improvement was that of the superposed lenses. He had not seen any lights of that character, but their advantages were obvious. When there was only one lamp, even though it were as broad as the one exhibited on the table, it might be obscured for the moment by spray or even by a bird flying (for birds were very much in the habit of flying towards lighthouse lamps), and various other causes, by which the mariner might be misled. With two lamps one above the other, with a series of lenses, that accident could scarcely happen, because the substance that obscured one light would not obscure the other. He could only express the great delight with which he had listened to the description of what were certainly great triumphs of engineering skill in the construction and illumination of a new, magnificent lighthouse in so difficult and dangerous a position.

Mr. VERNON-HARCOURT remarked that one point which had especially struck him was the cylindrical base, which would certainly be a great advantage in dividing the waves. No doubt it was true, as had been stated, that if the wave did not run up, it must strike a heavier blow; but it appeared to him that it was a great advantage that the wave should be so separated. Moreover, the blow would be dealt at a lower portion of the structure which,

Dr. Gladstone.
Mr. Vernon-Harcourt.

Mr. Vernon-
Harcourt.

both by its position, size, and solidity, would be much better able to support it. The height of the lighthouse was also an important consideration, and it was quite possible that the spray which reached the lower light would not reach the higher one. A protecting dam and a cylindrical base were adopted, in 1878, at the Stannard's Rock Lighthouse¹ in Lake Superior. The dam, formed of cribwork weighted with stones, protected the inner iron casing, 62 feet in diameter, which was filled with concrete on which the tower was erected. In some American rock lighthouses the simple conical form has been chosen for the towers instead of a curved batter, as, for instance, at Minot's Ledge and Spectacle Reef lighthouses; and the same design had been followed at the Ar-Men Lighthouse² off the French coast; but possibly, in these cases, the restricted available area of the reefs might have led to the adoption of this form. The flashing arrangements appeared to be remarkably good. At the Casquets there were until 1877 three lights for the purpose of distinction, when one flashing light showing three flashes in quick succession, at periods of half a minute, was substituted, which was a simpler method of indicating that particular light. They were revolving lights, but the period was rather long. He certainly thought that short flashes had a decided advantage over long ones.

Mr. Price
Williams.

Mr. PRICE WILLIAMS had had the privilege on several occasions of being present during the construction of the new Eddystone Lighthouse. The Author had stated that a great deal of the success and rapidity of the construction of the works was due to the mechanical appliances; and certainly anything more complete than the arrangements on board the "Hercules" it was almost impossible to conceive. He had especially noticed, at the early stages of the operations, the ingenious contrivance for pumping out water from the cofferdams, and also the arrangement of dividing them into compartments, so that a few minutes after the workmen got on the ground, and the pumps had been set to work, one of the compartments was ready. The contrivances for removing the stone from the ship's hold to the rock were admirably arranged, and the ship with its tramway on board was, in fact, a moving workshop. But what most impressed his mind, as a landsman, was the great apparent danger of the operations. There was exhibited a picture of the "Hercules" lying quietly moored near the rock; but he and his companions, who were landsmen, realized a very different idea when they were there. He often

¹ Minutes of Proceedings Inst. C.E., vol. lxxii., p. 353.

² Ibid., liv., p. 307

had misgivings when he witnessed the risk the men were running, and when it seemed that every wave was about to overwhelm them. But such was the discipline and the courage of the men, and such was the admirable way in which Mr. Douglass managed affairs, that he recognised on the first day, not only that the men were skilful in carrying out the engineering works, but that they were first-rate sailors. Those who were in command were always ready to share the danger; they carried their lives in their hands; wherever there was danger Mr. Douglass or his father was found on the spot. The Author had expressed his thankfulness that no fatal accident had happened. One ground of his thankfulness was his having so providentially survived the terrible accident to which reference had been made. With regard to the influence of the cylindrical base on the wave-stroke, he had noticed that the effect produced by it in breaking up the waves was enormous.

Mr. JAMES C. INGLIS said it was a matter of common knowledge before the new lighthouse was commenced that the vibrations in the old tower were considerable. The lighthouse-keepers had told him of various articles in the cupboards and elsewhere vibrating. He should be glad to hear whether any such vibrations had been observed or not in the new lighthouse. He had wished to see the mortar of which the old lighthouse was composed, and he had been surprised to find that many parts of it could be crumbled with the fingers; he would ask whether the excessive vibration had anything to do with that peculiar condition. Perhaps it might have arisen from the mortar having been so long exposed to the atmosphere. He had remarked the very superior character of the stonework in the new compared with that of the old structure. The joints in Smeaton's tower were $\frac{3}{8}$ to $\frac{1}{2}$ inch thick; in the new lighthouse they were $\frac{1}{8}$ inch, or perhaps less. It would be interesting to have some information as to the mortar, because evidently the old lighthouse, thin as it was, had to depend to a great extent for its stability on its weight. There was another point which he desired to mention, as being one in which people in the West were greatly interested; namely, the connection of the old lighthouse with the shore — not so much for commercial facilities as for giving information of ships in distress and requiring assistance—information which was received in Plymouth in a very desultory, uncertain, and haphazard way. It appeared to him that as the new lighthouse commanded an enormous expanse of water, it might be made useful in affording such information; at any rate the public would like to know what reasons there were for the telegraphic communication not being completed.

Mr. Price
Williams.

Mr. Inglis.

Sir Robert
Rawlinson.

Sir ROBERT RAWLINSON, C.B., supposed Sir James Douglass considered that there was great advantage in the vertical face in the lower part of the lighthouse tower in stilling the rise of waves. He wished to ask Sir James if he considered a second or a third tier of vertical faces would have been any detriment or any advantage to the lighthouse. In Sir Robert Rawlinson's opinion, it would have been an advantage. Waves of motion were brought to rest by a vertical face much sooner than by a sloping face; and if a sea-wall had to be subjected to the greatest possible wear and the greatest possible action of the waves, it would have a sloping face. He also wished to ask Sir James Douglass if he thought that the joggling of the joints of the ashlar represented on the plans was an advantage or not. It apparently locked the stones; and he assumed that it was done to prevent their moving. For himself, he did not see any advantage in the joint joggling. The old master under whom he was brought up, Mr. Hartley, in the commencement of his career caused ashlar masonry to be worked as perhaps no engineer ever caused it to be worked before. He tried "dodges" with it, putting raking beds against the heels of the hollow quoins upon curves. It was a difficult piece of masonry to produce, but he abandoned it in his mid-career as not serving any practically useful purpose. Masonry must depend upon gravity for its stability, and not upon any form of joggling to hold it together. There was a precedent for the joggling adopted by Sir James Douglass, because every course of Smeaton's lighthouse was not only joggled, but was dovetailed more elaborately than in the present lighthouse, since the courses were dovetailed into each other as well as being both joggled and dowelled. He had never been engaged in the construction of a lighthouse, but in his younger days he had made full detailed drawings of the Rock Lighthouse at Liverpool, which was an exact model of the Eddystone lighthouse. He therefore knew something of the construction of a lighthouse, and of the difficulties that had been overcome by Sir James Douglass. The younger members of the Institution, who had not had much practice in their profession, could scarcely appreciate from the mere reading of the Paper, the difficulties that had been encountered and overcome. The credit due to Sir James Douglass in mastering those difficulties was very great, and the title which Her Majesty had been graciously pleased to confer upon him was but a fitting reward for the ability he had displayed. Let them imagine that they had to work in a rough tideway, and to begin the construction at or about low-water; that they had to fight with moving

water in every stage of progress, and to continue the work even when it was almost as much as could be done to keep the boat at her moorings, going on as it were stealthily, stone by stone, getting the material to the site, and raising it gradually into position. The rapidity with which the work was done under those circumstances was, he thought, almost unprecedented. The members had heard the lowest estimate sent in by contractors who were supposed to know their business, and they had also heard the sum at which Sir James Douglass had completed the work carried on by the untiring energy and ability of his son. He was sure that Sir James Douglass would not consider that he was casting any discredit upon his constructive ability, by asking him if he considered that the joint joggling was necessary, or that it gave additional strength? There should be neither bent-beds nor mitre-joints, and it should be clearly understood that no form of rustication added strength. Arch-stones were wedges, that was, the beds should be true planes to the radius line of the arch. The stability of an arch must depend upon the resistance of the abutment and the true balance of the stones forming the arch, and not on bent-beds, joggles, dowels, or any other device or trick in construction. A graceful, well-proportioned and well-balanced bridge was the perfection of masonry.

Sir Robert
Rawlinson.

Mr. R. H. BRUNTON said it had been remarked by Mr. Beazeley that the Chinese had erected a number of iron lighthouses, which had "been made in England." He should be glad to know why they had been obtained from England, because in Japan several cast-iron and wrought-iron lighthouses had been erected which, with one exception, had been made by Japanese artificers, and the Chinese artificers in this class of work were equal, if not superior, to the Japanese. The Japanese not only made their own lighthouses, but the lanterns and the lamps, and even the plate-glass used in them. They did not yet make the dioptric apparatus, which they obtained from Paris. There was not now a single European in the employment of the lighthouse department of the Japanese Government. Probably, if Mr. Beazeley did not wish to share the fate of the Europeans formerly employed in Japan, he would still get everything he could from England. There appeared to be two points of novelty in the construction of the Eddystone lighthouse, the circular base, and the superimposed lenses. It had been said that the green seas rushed up Smeaton's tower to the cornice and considerably above, and that, in the case of the present tower, the circular base broke the waves which rushed round to the opposite side. If that were so, it appeared that the energy expended in projecting the volume of water, say 50 or 100

Mr. Brunton.

Mr. Brunton. tons, so many feet into the air, was now expended directly against the circular base. Of course the question came to be, whether the present tower had the statical resistance necessary to withstand that enormously increased force. With regard to the superimposed lenses, he should like to ask if the arrangement was intended as one of the first examples of the surrender of the principle of focal compactness, because certainly there was not a large focal compactness in two burners, of seven wicks each, in one lighthouse-lantern; or whether the theory of volume of light, as distinct from intensity, had not to some extent led to the adoption of these lenses? Before Fresnel introduced his system the size of the flames was the only thing on which the efficiency of the lights depended; but after Fresnel all efforts of lighthouse-engineers were directed, first, to the construction of an apparatus which would catch every possible ray; and, secondly, to the reduction of the focus as nearly as possible to its theoretical dimensions, namely to a point. It might be that lighthouse-engineers had ridden that hobby a little too far, and that a reaction was setting in; and he thought that the adoption of the superimposed lenses was an indication of that reaction. The doubling or quadrupling the size and the power of the light was carried out, this involving an enormous loss of light. With regard to the amount of loss, he had seen in a published despatch of the Trinity House to the Board of Trade, a statement that it was 12 per cent.; that, he thought, required a little explanation, which perhaps Sir James Douglass would give. In the Paper the maximum light of the unassisted flame in the new Eddystone was given as 1,900 candles, and the intensity of the beam from the apparatus was 159,600 candles, an increase of 84 times. With an octagonal complete revolving apparatus the increase was calculated at 250 times. From a twelve-sided apparatus, such as the one exhibited, the increase might be calculated at about 135 times. The increase given by Sir James Douglass being only 84 times, there was a loss of 37 per cent., and that agreed with what might be concluded from the apparatus itself. The refracting portion of a complete apparatus subtended an angle of 145° ; the lenses in the new Eddystone subtended, according to the Paper, an angle of 92° ; so that about 80 per cent. of the light was acted upon by a complete apparatus, whereas only 50 per cent. was acted upon by the new lenses; showing that there was a loss of 30 per cent., or rather, that 30 per cent. fewer of the divergent rays were parallelized by the new lenses. One other point required a little explanation. The maximum light of the new lenses, as given in the Paper, was 159,600 candles,

THE NEW EDDYSTONE LIGHTHOUSE.

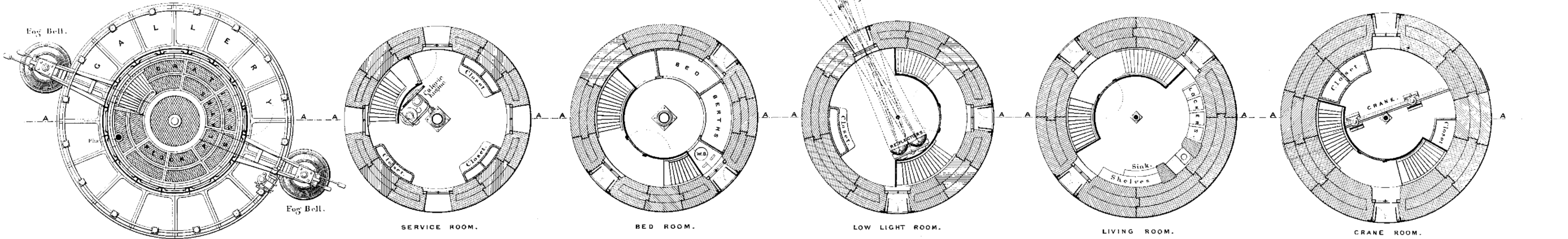

PLAN OF LANTERN AND GALLERY COURSE.

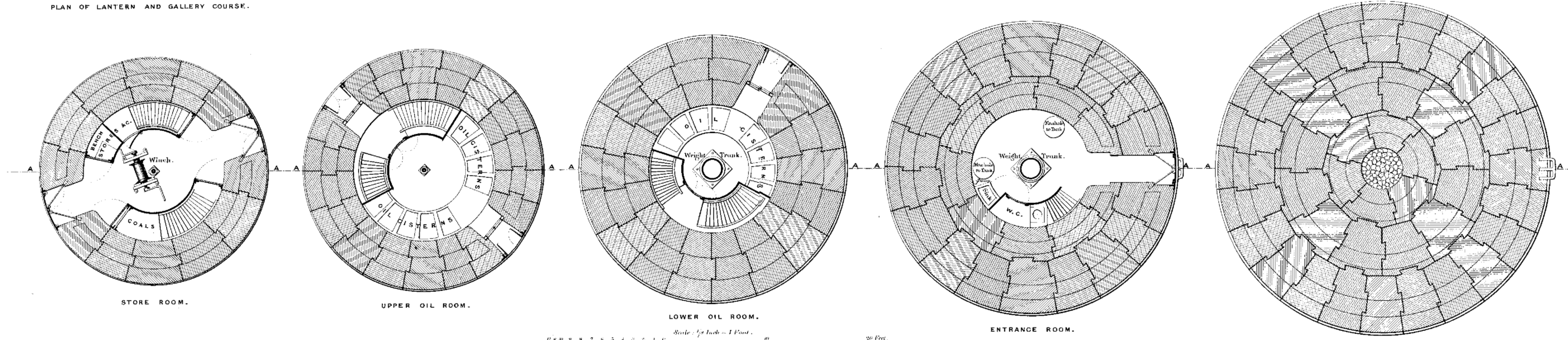

Scale: 1/8 Inch = 1 Foot. 20 Feet.

which was said to be 23·3 times that of the old Eddystone light-house : 159,600, divided by 23·3, would give 6,850 candles. Assuming that there was an old four-wick lamp in the old light-house, affording light equal to 300 candles, there was only an increase of about 23 times. Perhaps Sir James Douglass would explain what sort of apparatus was used in the old Eddystone, giving that small increase. He thought that the discussion of Sir James Douglass's Paper on the Electric Light applied to Lighthouses showed pretty clearly the correctness of the theory which Mr. Brunton had mentioned some time ago,¹ that volume of light was more important than intensity to penetrate a thick atmosphere. The reason given by the late Sir William Siemens had never been contradicted, that the violent agitation of a few particles in the atmospheric medium was more easily arrested by thick weather than the less violent agitation of a great number of particles; and if that was correct, it appeared to be quite plain that much of the ex-focal light served a definite purpose in putting into a state of vibration a larger area, and so resulting in its continuation to a greater distance. He thought, therefore, that focal compactness was a thing not to be too much strained after, and that Sir James Douglass had been quite right in adopting the incomplete apparatus which he had used in the new Eddystone. He had recently seen a remark made by the late Sir George Jessel, that if a person had conceived a new principle, or a new idea, with regard to art or manufacture, and then showed a way of carrying it into practice, he might patent that method, though he could not patent the idea. That appeared to be a very good indication of an excellent rule for engineering practice. Engineers might, without great impropriety, adopt the ideas of other people, if they were ideas only, but they could not very well, without proper arrangement, adopt ideas, which possibly at the expenditure of much time and labour, had been reduced to practice by other persons. Many people had thought of using mineral oil in lighthouses, but Captain Doty was certainly the first to put it in practice. Many persons also might have thought of using superimposed lenses in lighthouses, but Mr. Wigham was the first to show the practical utility and advantage of the method. He could only say that in his opinion the Trinity House mineral-oil burner, the superimposed lenses in the Eddystone Lighthouse, and the gas-lamp on the table were standing examples of an infraction of that salutary rule.

¹ Minutes of Proceedings Inst. C.E., vol. lii., p. 78.

Mr. Barry. Mr. J. WOLFE BARRY asked whether the cost of the work quoted in the Paper included the cost of the plant—the hire of the steamer, rent of wharves, and all the other matters which went to make up the total cost of the structure? No doubt, in making comparisons of the cost of various lighthouses, every allowance should be made for difference in expenditure under different conditions; but it would be interesting to know whether all the items to which he had referred had been included in the quoted price per cubic foot, which had struck him as being very small considering the great difficulties, labour and risk of such a work. He also wished to ask the reason for the selection of the height above high-water spring-tides which had been adopted for the cylindrical base? At first sight it would appear that heavy seas at high water would overtop the cylindrical part and cause damage, and he should be glad to know from Sir James Douglass whether the height chosen had been found sufficient, or whether he thought that it would be advisable in future structures to raise the cylindrical portion to a higher level.

Mr. Allam. Mr. E. C. ALLAM thought that the adoption of a cylindrical base by Sir James Douglass was a wise departure from the Smeaton model—a model which, up to the time of building the Great Basses Lighthouse, had, he believed, been followed in every case of the erection of a rock lighthouse-tower. A rock lighthouse-tower was subject to two destructive forces, those of the winds and of the waves. Smeaton had observed that he conceived the idea of the form of his tower from the trunk of an oak. If a lighthouse-tower was, like an oak-tree, subjected only to the force of the wind, that form would be perfect; but in point of fact there was no analogy between the two cases. In the case of the oak-tree the overturning force was exerted almost entirely at the top, and in the case of the lighthouse it was exerted almost entirely at the base. The force of the waves, too, was so far in excess of that of the wind that the latter might be practically disregarded; for, if a lighthouse-tower was strong enough to withstand the force of the waves, it would certainly be strong enough to withstand the force of the wind. A lighthouse-tower might be destroyed in either of two ways, either by being moved bodily by the sliding of the base upon its foundation, or by being fractured at some point in its height, and the upper portion being overthrown. In the generality of cases it was so easy to guard against the first mode of destruction by sinking the tower into the solid rock, as in the case of the new Eddystone, that the attention of engineers should be mainly directed to the question of destruction by the second method. A wave advancing against

and being checked by such an obstacle as a lighthouse-tower, had Mr. Allam. two courses open to it: it might either divide, and, forcing aside the mass of water on either hand, pass at once to the rear, or it might rise up the face of the tower. If the diameter of the tower was comparatively small, and the face perpendicular, it would generally be found that the wave would take the former course; if, however, but a slight inclination was given to the tower there was a tendency in the wave to rise up the face. The tower that had the most spreading base with which he was acquainted was that of the Bell Rock Lighthouse, and this climbing action of the waves was there well illustrated, as shown in Turner's celebrated picture of "The Bell Rock Lighthouse during a storm." In his opinion that form of tower was wrong in principle. To divert the wave from the solid base where it was best able to withstand the shock, to cause the base, as it were, to shirk the duty which it was so well able to perform, and to send the wave aloft to strike against the less solid portion of the tower, seemed to him like the action of a commanding general who allowed the enemy to break through the front ranks of his army where his veterans were stationed, and fall almost unchecked on the recruits in the rear. With reference to the disintegrated condition of the mortar in the old tower, he should like to ask Sir James Douglass what connection he considered existed between that state of things and the vibrations noticed in the tower, whether the vibrations caused the disintegration, or whether the decay of the mortar had anything to do with the insecure condition of the tower itself? It seemed almost sacrilege to hint even at any imperfection in Smeaton's Eddystone, but it was in no sacrilegious spirit that he asked the question. He had been up Smeaton's other tower, that at Spurn Point, when, to use the expression of the keeper, "it was rocking like a ship's mast," although the diameter of that tower was very large in proportion to its height. In that case, however, the oscillation was not produced by any instability in the building itself, but resulted from the elastic nature of the sandy foundation on which the tower was built. It was a cause of universal regret that the necessity should ever arise for taking down Smeaton's tower, but that necessity having arisen it was satisfactory to know that it had been superseded by such a fine structure as the present lighthouse. With regard to the Douglass lamp now being introduced into the Eddystone and other lighthouse-towers, he could only say that if such a light as that exhibited on the table could be produced from either gas or oil, Electric-light engineers would have to look to their laurels. While

Mr. Allam, thanking Mr. Douglass for his excellent Paper, he thought with their thanks the members ought to join their congratulations upon his providential escape while carrying out so difficult and dangerous a work.

Sir James Douglass. Sir JAMES DOUGLASS desired to unite with the Author of the Paper in his expressions of thankfulness that the work had been carried out without the loss of a single life. It was also a great satisfaction to him to know that it had been carried out somewhat below the sanctioned estimate, a result largely due to the able assistance he had received from his staff at Trinity House, and on the works, also to the earnest zeal of all the men employed at the work. Every man was eager and zealous in following their leaders who always acted on the example of their noble craftsman, Smeaton, in being foremost at the post of danger and honour. He was quite sure that every man who had been employed at the work would to the day of his death consider it a glorious privilege to have been permitted to assist in it. He mentioned the circumstance because it showed the importance of engaging the earnest sympathy of all the men employed in a work of that kind. The number of men was necessarily limited, and unless every man was willing and determined to do his duty, success could not be expected. He desired also to record thanks to the contractors for the granite, Messrs. Shearer and Company, for their excellent material and workmanship, and for their having completed the work six months within the specified time. He had great pleasure in making that acknowledgment, because in his experience it was very uncommon to find a granite contract completed within the time. It might be desirable to say a few words with regard to his deviation from the curve adopted by Smeaton for such a structure. The question of arresting the force of a large ocean wave on a structure of that kind had long engaged his attention, and he had come to the conclusion that for heavy seas the only form to be adopted for a lighthouse-tower was a cylindrical base. It was true that it received a heavier blow on the curved surface, but the blow was delivered at a point where the structure was best able to receive it, and at the point of least leverage, and thus of least destructive effect on the rock-foundation below. Mr. Beazeley and Sir Robert Rawlinson had referred to small stepping, contrasting it with the large stepping or cylindrical base. The stepping of each course of the masonry was adopted by the late Mr. James Walker, Past-President Inst. C.E., in 1834 at the Menai lighthouse, and it was no doubt the right method where small waves were dealt with. There were examples of the small stepping at

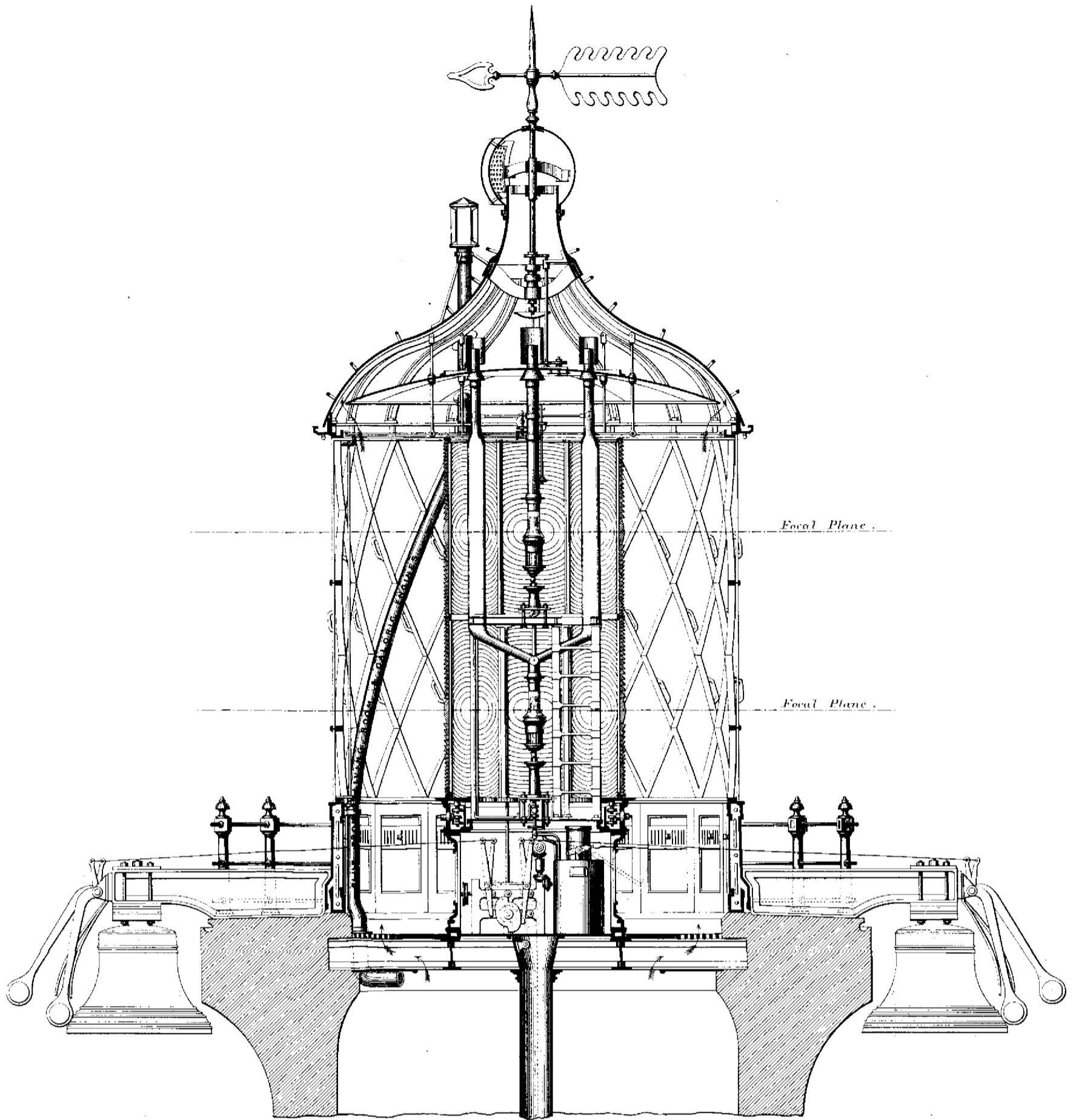

SECTION OF LANTERN AND DIOPTRIC APPARATUS, WITH FOG BELLS AND MACHINERY.

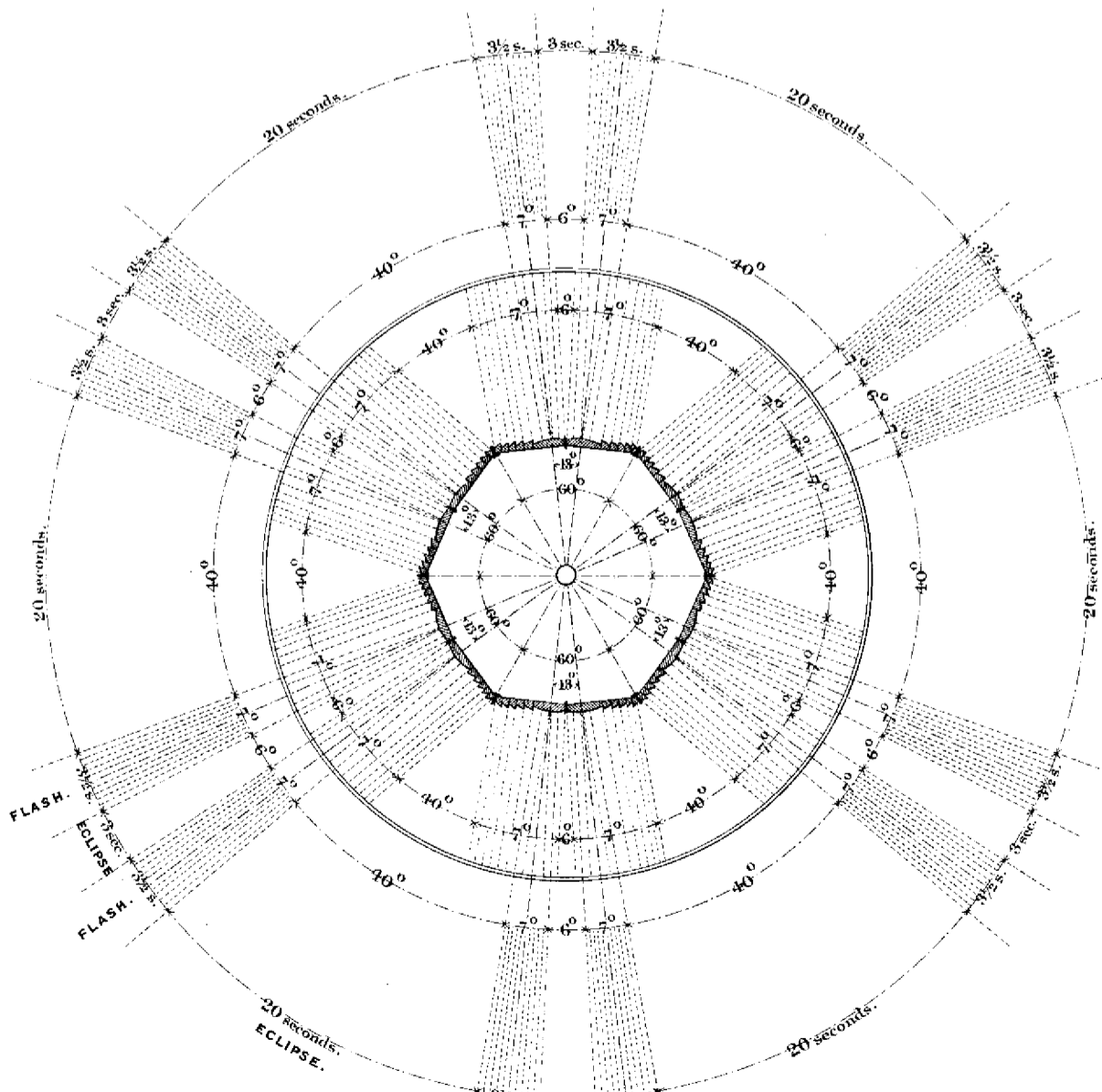

DOUBLE FLASHING LIGHT, 1/2 MINUTE PERIOD. DIAGRAM OF FLASHES.

Scale: 1/4 inch = 1 Foot.

1 2 3 4 5 6 7 8 9 10 11 12 13 14 15 16 17 18 19 20 21 22 23 24 25 26 27 28 29 30 31 32 33 34 35 36 37 38 39 40 41 42 43 44 45 46 47 48 49 50 51 52 53 54 55 56 57 58 59 60 61 62 63 64 65 66 67 68 69 70 71 72 73 74 75 76 77 78 79 80 81 82 83 84 85 86 87 88 89 90 91 92 93 94 95 96 97 98 99 100

the Bishop, Wolf, and other rock lighthouses, but it was found that the effect was very feeble in arresting the upward trend of a very large wave; indeed it was little more than might be obtained from a roughened surface of the curve of Smeaton. With the large cylinder the wave was immediately divided, and prevented from rising, which was very important in the case of a lighthouse, because the first consideration should be to prevent the sea from reaching the lantern and impairing the distinctive character of the light. There was also another important consideration, namely that of arresting the heavy stroke of the falling wave, and preventing, especially where the rock was soft, injury to the foundation below. He would prefer that the downward stroke be received on the masonry, forming as it did a piece of solid granite, rather than upon a doubtful piece of rock below, as at the Eddystone. With regard to the effect of the sea on the Eddystone, the diagram, rough as it was, fairly represented the actual state of things. The Author in the original diagram had shown the appearance of the sea as observed from the new tower during a heavy gale, and Sir James Douglass had since added a representation of the appearance of the sea as given by Smeaton in his narrative. It should be remembered that in the one case the sea in a gale was represented where the lighter portion of the crest of the wave was broken up and driven to leeward by the force of the wind, while in the other case it was, as Smeaton stated, on the morning after a storm, when the waves rose higher on the tower, and fell nearly perpendicularly on its lee side. He could bear testimony to the correctness of the diagram. He had been on one occasion detained three weeks in the tower during stormy weather, and he had the opportunity of observing both heavy ground seas without wind and heavy seas during storms. He was much amused when the first storm came on by the keeper on watch telling him that he must wedge up the shutter of his bed-berth if he wished to sleep. He found attached to the shutter by a lanyard the required wedge, but he first tried to sleep with the shutter rattling with every wave-stroke on the tower; finding this impossible he was compelled to apply the wedge, when he managed to sleep soundly. He spent much of his time in watching the seas, and reading the excellent books provided by Trinity House; the time passed very happily, and he believed with profit. With regard to the dovetailing or joggling, he considered that in such a work it was of very great importance. It did not add materially to the cost of the structure, but it added immensely to the reliability of the work step by step as it was carried on, and thus facilitated its construction.

Sir James
Douglass.

Sir James He did not know any other system by which it was possible to
 Douglass. set masonry with such readiness where exposed to heavy seas. By
 the method adopted each stone was supported not only by the stone
 below, but by the stones that were beside and behind it, so that it
 could be left immediately after setting with perfect certainty.
 They had never lost a stone there; a few were lost at the Wolf, but
 there was every reason for concluding that they had been struck
 by wreckage. From that point of view alone he was quite certain
 that the system was worth the money expended on it; but in addition
 to this a complete water-stop was provided at each bed and
 joint, and it rendered the work a perfect monolith. He did not
 believe that it was possible to procure from any of the granite
 quarries of this country a mass of granite of the same dimensions
 more perfectly homogeneous. Another point was the security
 given by the system to the walls, with the strain imposed upon
 them by the system adopted of erection by steam-machinery afloat.
 Had not the work been put together in the manner described they
 could not have ventured to take lifts from the steamer with rough
 water as they did. With reference to the question of luminaries,
 it was evident that no lighthouse could be considered as completely
 fulfilling its functions unless it was provided with a good light.
 His attention had been directed to this question for many years,
 and always in the direction of condensing flame-luminaries to the
 utmost possible extent. The model exhibited was of the Fresnel
 burner with its flame $3\frac{3}{4}$ inches diameter and 4 inches high. That
 flame was carefully calculated by Fresnel for application in his
 optical apparatus of the first-order dimensions, at 920 millimetres
 focal distance, so that the vertical divergence where the rays of
 maximum intensity were sent direct to the sea-horizon, should just
 be sufficient to illuminate the sea from the horizon to the shore
 without waste. It was also so calculated in its diameter as to be
 utilized with the greatest possible economy for flashing lights, of
 the required length of flashes of one-quarter minute, half-minute,
 or one-minute periods. The flame-luminaries of Fresnel were also
 proportioned to the six sizes of apparatus, from the four-wick burner
 down to the single wick. Sir James Douglass had therefore worked
 in the direction of raising the initial intensity of the flame-lumi-
 naries for first-order optical apparatus without unduly increasing
 their dimensions. In the Eddystone burners he had doubled the
 focal dimensions of the flame, but he had raised the intensity from
 269 candles to nearly 1,000, so that he had more than doubled the
 initial intensity per square inch of the focal area of the luminary.
 It was true that there was less economy in using such a flame with

IMPROVED FIRST ORDER PRESSURE LAMP.

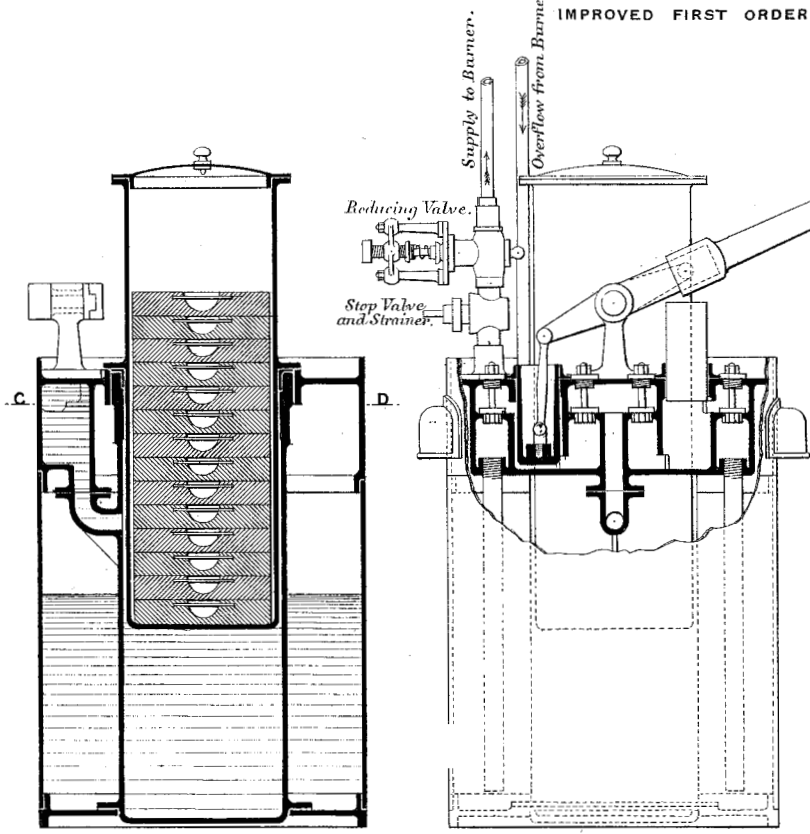

SECTION ON LINE A. B.

ELEVATION OF LAMP.
(FORCE PUMPS IN SECTION.)

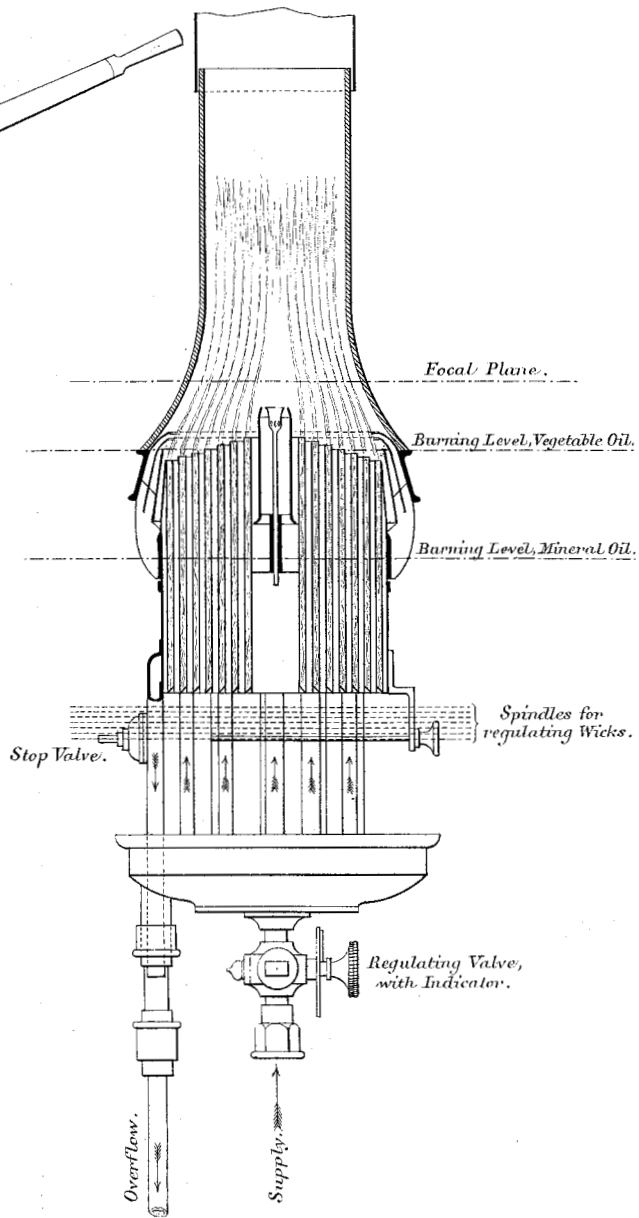

7 WICK "DOUGLASS" BURNER.

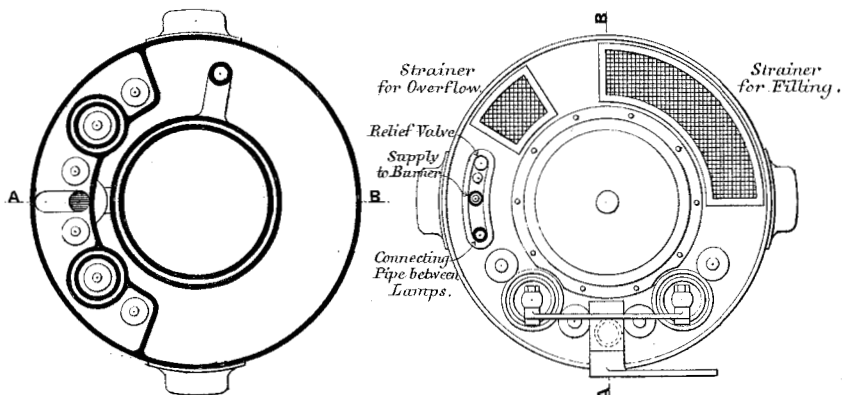

SECTIONAL PLAN AT C. D.

PLAN.

Scale: 1 Inch = 1 Foot.

Scale: 2 Inches = 1 Foot.

for Lamp.

for Burner.

the first order apparatus, but there was a higher intensity in the resultant beam, and the flashes were somewhat prolonged, which generally satisfied the mariner. On the other hand, with regard to the vertical divergence, there was more in-shore illumination, which was also an advantage. But while the utmost had been done for oil- and gas-flames, what had occurred with regard to the electric light? When comparing the initial intensity of flame and electric-arc luminaries, it was found that where the electric arc was applied they had 200 times the intensity per square inch of focal area of that of the best oil- or gas-flame. He thought there could be no better proof than this of the immense value of the electric light in the focus of optical apparatus for penetrating a thick atmosphere. He might be permitted to say a few words on the subject of penetration. When on the 8th of December, 1858, Holmes installed his electric light at the South Foreland, it was seen that greater distances would be penetrated through fog than had been previously considered to be possible. Since that date there had been a spirited rivalry between oil- and gas-flames and the electric light, and that had in a great measure led to the flames exhibited. It might be well to review what had occurred at the Eddystone since Smeaton's time. Smeaton's 67-candle light was sufficient to reach the sea horizon during clear weather, 14 miles distant, but unfortunately on the English coast, especially during winter, clear weather was the exception and not the rule. Taking an instance where the present light was just visible at 14 miles, in such a state of atmosphere Smeaton's 67-candle unit light would reach only 4 miles. In another case where Smeaton's light would just be visible at 1 mile, a distance that could now be covered by a sound signal, the present light would penetrate $3\frac{1}{2}$ miles, and if electricity were to be applied in its present condition of maximum intensity with reliability, another mile would be added. Looking at electricity from that point of view, it was very satisfactory to know that it was not only the most powerful luminary, penetrating the greatest distance for coast-light purposes, but that it was per unit of light provided the cheapest. Under the circumstances referred to, the cost would be about one-third that of gas and about one-half that of mineral oil. Mr. Brunton had referred to some remarks of Sir William Siemens. Sir James Douglass was glad to be able to remember some other words of Sir William Siemens, uttered in that room on the evening of the reading of his Paper on "The Electric Light applied to Lighthouse Illumination," words which appeared to be quite different from Mr. Brunton's recollection. With regard to the ques-

Sir James
Douglass.

Sir James Douglass. tion of focal compactness of light "it was true that Mr. Wigham had said he liked his light ex-focal, in order to give a glare; but Dr. Siemens apprehended that few persons would coincide with Mr. Wigham in that view. It might be an advantage in looking at a light at a short distance, but the ex-focal light would give very little effect at a great distance."¹ That view must be endorsed by any man who was acquainted with the practical application of a powerful luminary in an optical apparatus. With reference to the items of cost, the Secretary of Trinity House was present, and would be able to endorse anything that had been stated by the Author of the Paper upon that point, and to testify to the correctness with which the accounts of Trinity House were kept. He might say as their Engineer, that he had been taxed with every farthing fairly chargeable to the work as it progressed step by step, including the cost of the plant. With reference to the question put by Mr. Barry in regard to the height of the cylindrical base, he believed that the summit of the base was at about the right position for the Eddystone. With no heavy sea rising to the upper part of the tower he believed that its statical resistance would be sufficient to meet everything going against it. It was found that there was scarcely any perceptible tremor in the structure. The chief consideration with regard to the base was its convenience as a landing platform on all sides, and if it had been unnecessarily raised it would have been rendered inconvenient in that respect. If the lighthouse had been further westward, say off the Scilly Isles, with heavier seas than at the Eddystone, he should certainly have raised the cylindrical base higher, possibly 8 or 10 feet.

Ir. Douglass. Mr. W. T. DOUGLASS in reply upon the discussion stated that he had been favoured with a communication from Sir George Airy, Hon. M. Inst. C.E., who had devoted much attention to wave-action, relative to the cylindrical form of base adopted for the new Eddystone, in which he fully concurred. Sir George Airy, however, expressed some fear that the water might be driven into the joints below the coping stones of the cylinder, and that it might exercise an almost irresistible force in lifting these stones. His own opinion was, considering the manner in which the work was dovetailed and cemented together, that it was an impossibility that any such damage could occur, unless the work was struck by floating wreckage, impelled by a heavy sea. The mortar of the old tower throughout the portion of the masonry that was removed, was uniformly hard and tough. On lifting the stones

¹ Minutes of Proceedings Inst. C.E., vol. lvii., p. 156.

forming the lantern gallery, which had been previously loosened Mr. Douglass. from time to time, and where the sea had been occasionally driven through the beds and joints, a thick deposit of salt was found on the upper surface of the cement beds, yet the mortar even here showed no sign of deterioration. Some samples of this mortar were laid on the table for inspection. The effect of the vibration and leverage of Smeaton's tower upon the rock-foundation, in facilitating disintegration, was manifest from the fact that fractures had occurred in the rock directly across the line of direction of the laminations, and where the rock had previously been sound. Referring to the suggestion that the ideas of others had been adopted at the Eddystone, he considered it difficult to conceive how an engineer could possibly design and execute any important work in all its details on entirely new ideas, and he was not aware that such an impossibility has been suggested in the Paper. With reference to the employment of superposed lenses, he had given an historical *resumé* of their development, from which it would be seen that the idea was not that of Mr. Wigham, neither was their first application due to him, for he should have stated that this was due to Professor Holmes, who introduced superposed lenses for the electric light at Dungeness Lighthouse in 1862, and they were afterwards adopted by Mr. E. Allard, director general of the lighthouses of France at La Héve Lighthouse¹ in 1863. He had clearly shown by the diagrams that the method followed at the Eddystone differed entirely from Mr. Wigham's. Again, coal-gas and mineral oil had been in use as lighthouse luminaries for many years before gas was suggested by Mr. Wigham, or mineral oil by Captain Doty. Coal-gas was first employed in this country for coast illumination in 1827, at the Troon Lighthouse which was also the first Lighthouse where provision was made for increasing the amount of light during thick weather, fifteen gas-jets being ordinarily employed, which were increased to twenty-five during fogs. Mineral oil was first used in the French lighthouses about the year 1860, and at the Lune lighthouses in this country in 1869. Further he had shown by the diagrams and models, that the burners of Sir James Douglass, both for coal-gas and mineral oil, differed entirely from those referred to by Mr. Brunton.

By the kindness of the Elder Brethren of the Trinity House he was enabled to exhibit the clock originally placed by Smeaton in his tower on its completion, and which was still in efficient

¹ Minutes of Proceedings Inst. C.E., vol. viii., plate 3.

Mr. Douglass. working order. Smeaton stated in his narrative (p. 170), "A time-piece I had provided was set up and put in motion. This time-piece by a simple contrivance being made to strike a single blow every half-hour, would thereby warn the keepers to snuff the candles."

Correspondence.

Mr. Mosse. Mr. J. R. MOSSE remarked that, through the courtesy of Mr. William Douglass, M. Inst. C.E., who was then constructing the Great Basses Lighthouses, Ceylon, he visited the works in 1872. Although workmen had landed on the rock that morning, the sea subsequently rendered landing impossible, and he had therefore to watch the process of landing the stones from the screw-steamer "Hercules," which was moored broadside on to the Basses rock. As described in the Paper, the stones were raised from the hold of the vessel by a steam-winch placed forward of the hatchway, and to the stone another chain was attached, which, after passing through a block fastened to a derrick on the rock, was wound round the steam-winch near the stern of the steamer. As the former winch slackened the stone was hauled by the latter winch through the water, and landed by the derrick on the rock; the whole process occupying some five or six minutes for each stone. Nothing could be neater, more simple, or satisfactory than this system. As regarded the height of the vertical circular base, he presumed it should depend upon the height to which the crest of the waves rose in storms, so that the main force of the water might be broken on the base, rather than on the tower, up which the waves would otherwise rise. Probably to utilize the masonry prepared for the proposed "Gordon" Lighthouse, the height of the vertical base of the Great Basses Lighthouse was about 32 feet above high water.

Mr. Wigham. Mr. JOHN R. WIGHAM observed that the Paper had been of peculiar interest to him, both from his long connection with lighthouse matters, as also from the fact that he had the pleasure, in company with the Author, of visiting the new lighthouse-tower, and of standing upon the old one, and looking at the Author's admirable arrangements for demolishing Smeaton's great work. He had much pleasure in acknowledging the great courtesy and kindness of the Author during the visit. A finer structure than that of the new Eddystone did not exist; and the details of every part, down to the most minute particular, were such as to command admiration. The portion of the Paper upon which he desired