

## Discussion.

Mr. EDWARD WOODS, President, said that the Author had devoted Mr. Woods. a long experience to the subject of laboratory appliances, and his Paper was most valuable and interesting, not merely to students but to engineers in general; many engineers, like himself, were glad to avail themselves of the Author's assistance in carrying out experiments upon iron and steel work under their construction.

Professor A. B. W. KENNEDY observed that all who had had to do Professor Kennedy. with the preparation of a Paper containing so much matter that was cyclopædic rather than original, would know how difficult it was to make such a Paper complete. He had done his best, but he should be exceedingly obliged if members would point out any omissions, which he was afraid were numerous, but they were unintentional. In consequence of the length of the Paper, he had felt constrained to limit himself rigidly to the subject-matter of its title; he had therefore been compelled to omit all reference, practically, to three matters. In the first place he had not referred to what might be called educational workshops, of which there were many. The relative value of such institutions, as compared with engineering laboratories, was no doubt a very important matter, but he could not include any description of them in a Paper which professed to deal only with laboratories. Secondly, while he thoroughly recognized the importance and value of what might be called laboratories of applied mechanics, he had omitted them, and he had also made no reference to electro-technical laboratories. It was not that he undervalued either of those classes of institutions, but that it was impossible to deal with them even within the very unreasonable limits that he had already set himself. He wished to supply two omissions. When the Paper was written, he did not know that at the Sheffield Technical School of the Firth College there were not only workshop appliances of a very elaborate kind, but also an experimental engine and boiler, and that a testing laboratory in addition was being fitted up. These were, he believed, under the care of Professor W. H. Greenwood, M. Inst. C.E. The school itself was opened by Sir Frederick Bramwell, about two years ago. He ought also to have mentioned that at King's College, London, in addition to the well-known workshops, there was a testing-machine of the Greenwood type. His Paper dealt especially with experimental appliances connected with educational work of various kinds, not with experimental appliances *per se*. His desire was

Professor Kennedy. that his Paper should really form a peg upon which to hang remarks as to the experience of practical engineers in regard to their methods of carrying out their many experiments. If the discussion should be so extended, it would, he believed, prove a great deal more valuable than the Paper. With the President's permission he would show the members one experiment before the discussion commenced. He had with him a little apparatus designed by Mr. Ashcroft and himself; it was essentially a small testing-machine on the same principle as the diagramming apparatus of Plate 9; but used without any dead-weight measurement of load, and in other ways much simplified for the purposes of demonstration. (Professor Kennedy then showed upon the screen, by aid of the apparatus mentioned and a magic lantern, the stress-strain diagram of a piece of Swedish bar iron, the diagram becoming visible upon the screen as the test of the iron was proceeding.)

Professor Reynolds. Professor OSBORNE REYNOLDS said he was present in the position of a learner, and was himself perhaps as much interested in the work as any one in the room. At the Owens College an engineering laboratory was being erected and fitted up very much after the pattern which the Author had conducted for several years, and already his kind advice and experience had proved of great use. He should say but little in reference to the detailed experiments described in the Paper, although he wished to compliment the Author on the extremely beautiful illustration he had just given, and on the perfection to which he had brought a most difficult experiment, that of exaggerating, and drawing as a diagram the curve of extension within the elastic limits of a bar. The whole extension, before the elastic limit was reached, was so minute, that it required an extreme degree of accuracy to measure it, and yet it was brought into a line, in some of the diagrams given in the Paper, which had a slope of  $25^\circ$ ,  $30^\circ$ , and even  $40^\circ$ . That, he thought, was a result which deserved a high place among mechanical achievements. He should like to say a few words with regard to the educational position and importance of that kind of laboratory work. Although there had hitherto been no definite laboratory at the Owens College, there was a workshop and a steam-engine, and there was a laboratory of his own where experiments were conducted, not particularly with regard to the strength of material, but with regard to what might be called the determination of the laws and constants which related directly to the subject of practical mechanics. Those experiments had been conducted for the purposes of research, and only incidentally used for teaching. The Author had stated that he started with the idea of making his

experiments an instrument of education as distinct from the question of research, and he deserved great credit for adopting that course. He did not know that any one else had taken up the subject from that point of view, and it required no inconsiderable amount of courage to make such a trial. It was all very well to make experiments for research, but it was quite another thing to try and teach by experiments. When a system had been perfected there was nothing more pleasant than to teach experimentally, because it was certain that everything would happen as it was expected—a definite system was being taught; but with new or somewhat uncertain apparatus, and work that was not perfectly straightforward, it was difficult to keep the attention of the student. Hitches would be likely to occur which might afford food for thought to the person engaged, who understood all about the experiment, but which sadly distracted the attention of those who were learning to make experiment itself. And not only so, but the teacher had to devise every detail, and to find sufficient work to occupy the attention of all engaged. The Author had undertaken that kind of work, and had carried it out to a satisfactory, he might almost say a triumphant, issue. No more important step could be taken, in advancing mechanical teaching, than that of inaugurating a successful system of mechanical laboratory teaching. With regard to the expression “engineering laboratory,” he might say that it was one which he much wanted many years ago. Since 1872 or 1873 he had been endeavouring to induce the authorities of the Owens College to increase the facilities of illustration and work for the engineering students; but although he had done his best to bring it about he had not succeeded until after the Author had set the example, and he believed that the term “laboratory” had as much as anything conduced to his success. There was a great shyness about establishing a workshop, but the moment a laboratory was talked of, all opposition disappeared. No doubt the term had more correctly expressed the work carried on, and perhaps the aptness of the expression had had something to do with the result. At the Owens College the matter was now in a fair way of progress. A building 80 feet long by 75 feet wide and 20 feet high, with both top and side lights, was nearly finished. Several machines of the best kind had been ordered, and having the assistance of Mr. John Ramsbottom, M. Inst. C.E., and Mr. John Robinson, M. Inst. C.E., and taking advantage of previous experience, modifications were being introduced. A complete start would be made next session of a system of instruction very similar to that adopted by the

Professor  
Reynolds.

Professor  
Reynolds.

Author. There could be no question as to the importance of researches conducted in laboratories of that kind. The whole engineering profession had recognized the work of the Author and others as conferring a great advantage upon the profession; but he was not so sure that its value as a training for would-be members of the profession had been recognized. A great deal might be said in regard to the importance of that kind of training. There were two ways chiefly of looking at it. The objects sought in the engineering laboratory should be to teach students, and particularly to enable them to practice those methods of measurement which belonged to the engineer and not to the artisan. The necessity for a laboratory course, to complete the education of an engineer, had arisen from the institution, which had taken place of late years, of definite mechanical tests both for the strength of materials and for the efficiency of machines. But the object was not solely or mainly to make accomplished experimenters or testers. The revolution which had introduced these tests might be regarded as the result of the scientific education of engineers. It was only by the theory of structures that they were able to deduce the strengths and elasticities of the infinitely various structures, to be met with in practice, from the simple experimental tests to which material could be subjected; and, in the same way, it was only by a knowledge of the theory of the machines that they were able to make definite use of measurements of efficiency. The theory of applied mechanics had been in every particular framed upon more or less definite experimental results, but the only experiments available for this, up to a few years ago, were those carried out by the founders of the science. In the meanwhile the theory of applied mechanics, as embodied in Rankine's works, had been assimilated bit by bit; and the important results to be obtained by the aid of the theory, where definite experimental results were forthcoming, had become more and more evident, until it might be said that there was scarcely an important contract in which definite tests were not specified for all the manufactured material used. Steam-engines were tested by the indicator. It was not improbable that in a few years all machinery might be tested. The testing of materials and machines had become an important part of engineers' work; that importance was steadily increasing, and with it the higher theoretical training to which it was distinctly complementary. The question was being asked, was the mechanical laboratory going to be substituted for other training? It was not, or should not be, a case of substitution. The experimental part, as introduced in a mechanical

laboratory, was a necessary complement to the theoretical teaching, in order that it might be fully appreciated. To teach a theory without having the circumstances, more or less, before the students, was like teaching the language of a country to those who were unacquainted with the things to which the substantives of that language applied. In the mechanical laboratory there was only a small part of the circumstances of engineering; still some of the very highest class of mechanical practice was placed before the student, and that alone gave an interest to the work which more than balanced the time that might be occupied. Professor Reynolds.

Mr. J. H. WICKSTEED remarked that the Author had introduced the use of an accumulator for making tests, and it would be interesting to know something more of his experience in reference to that method. He had referred to the way in which he throttled the water. In order that the test might be conducted steadily from first to last through the variations of resistance of the sample, beginning with almost no resistance at all, he found it important to have the accumulator pressure very considerably in excess of the resistance of the sample, and then to throttle the passage of the water in order that the extension of the sample might be tolerably uniform. He had also spoken of throttling the passage of the water with two valves. Mr. Wicksteed wished to know whether that was an accidental arrangement, or whether the Author had found that he could more successfully make the speed of the inflow of the water uniform by the use of two valves than he could do by the use of one valve. The Author had adverted to the convenience of a horizontal machine, where long specimens were being tested, because the specimen was at a uniform height, which might be made the most convenient height for the observer. But it always appeared to Mr. Wicksteed that it was a point of great importance to put the specimen vertically when making experiments within the elastic limit, because it was surely better to multiply the length of the specimen itself (taking a 100-inch specimen) than to multiply by mechanical gearing the readings taken from a short specimen, say 10 inches long. If a specimen 100 inches long were placed horizontally, it would sag unless it was supported at frequent intervals by balance-weights or some other arrangement, and that would be inconvenient. Then, if there was a sag upon the specimen, in making a delicate experiment of elasticity, there would be great difficulty in separating the extension of the piece that took place through the lifting up of the part that had sagged. If a specimen was dropped vertically down like a plummet, and hung from one of the joints which had been Mr. Wicksteed.

Mr. Wicksteed. designed by the Author, and which he had himself taken the liberty of copying in some of his practice, and if it was brought from a ball and socket-joint, and held on underneath by another ball and socket-joint, it afforded the opportunity of plumbing the apparatus with a plumb line, the axis of the specimen fell through that line, the pull was straight, and the specimen hung down without sag. That, he thought, was a condition under which it was possible to make elastic experiments with the greatest advantage. If so, it would be a pity to encourage the use of a horizontal arrangement, simply because of the extra feature of a hydraulic lift to enable the experimenter to traverse any distance he liked, up and down a vertical specimen. The Author had spoken of the impossibility of proving the sensibility of knife-edges by the use of dead-weights. It was not impossible, and indeed it had been done. The Consett Iron Company, having a vertical machine, had made a large cradle, which had been suspended to the back centre of the machine. The cradle had been balanced with a weight hung from the end of the lever, and loaded with adjusted 56-lb. weights to the extent of 40 tons of actual dead-weight. The monkey-weight had been rested upon the steelyard to balancing point; the reading from the vernier on the steelyard had then been taken and noted, and also in another column the weights put into the cradle, by which means the reading of the steelyard had been checked through the entire range of the machine, and when the whole 40 tons had been upon the machine, the thing was floated, and nothing remained to be done but to add a sufficient weight to the end of the lever to make it move, so that it was possible to tell exactly what friction was upon the knife-edges. It was sufficient to see that the balance was correct, that the apparatus was sensitive, so that it could be moved up and down with the finger and thumb. Although, therefore, the Author's estimate of  $\frac{1}{2}$  lb. per ton was a very reasonable one, he thought the degree of sensitiveness might be made a great deal finer than that. The Author was in the habit of reducing the load carried by the carriage that travelled upon the steelyard for delicate experiments. He could not see the advantage of that system. It seemed to him that the nearer a dead-weight was approached the more perfect the experiment was likely to be. For the very finest sorts of weighing the scale-beam was used, a beam with equal arms. The total load was on one side, and the total weight on the other. Supposing, to commence with, a weight heavier than that which had been quoted in his machine, 1 ton, say even 2 tons, he could not see that that weight would be too heavy for testing horsehair or silken thread, because the propor-

tions of the levers could be reversed. The massive weight could be made to have a very small ratio of mechanical advantage over the specimen ; indeed it might be actually reversed, so that the specimen might have a mechanical advantage over the weight. Instead of reducing the weights which ran along the lever, he would adopt the plan of altering the ratio of mechanical advantage of the lever. Thus if at first the lever had a mechanical advantage of 50 to 1, and did heavy work, if it was wanted to do light work with it, a supporting plate could be brought up underneath a knife-edge that was fixed in the lever in another place, and so arranged that the lever should vibrate upon the knife-edge with a mechanical advantage of only 25 to 1 ; or it might be even in the centre of the lever, where there was no advantage at all, which would be an equal scale-beam. He thought he saw his way to making a machine, very simply, in which a knife-edge could be brought to bear in the centre of the lever at  $\frac{2}{3}$  of the distance, or at  $\frac{1}{3}$  of the distance if required. He had gone in the direction of increasing the weight upon the lever to 2 tons, and he believed that the less number of times the weight was multiplied upon the lever into the test-piece, the less would errors be multiplied, and the nearer would be the approach to an absolute weight that could be sworn to. That was the direction in which he was working in a machine now being constructed for Professor Reynolds at the Owens College.

Professor W. C. UNWIN said that as he had been engaged more or less in work of the same kind, he could appreciate fully how very much labour and skill must have gone to the organization of the laboratory at University College. The Author might well feel proud that he had taken the initiative in introducing that kind of technical instruction in this country, and also that, in an Institution which had not been generally celebrated for its wealth, he had been able to carry out his plans on so large and practical a scale. The first point which the Paper raised was as to the precise way in which a mechanical laboratory was to be used, and the Author had made a point of the fact that he was the first to make students take part in carrying out experiments in the laboratory. He had no doubt that, in introducing that plan, what had been done was best for the students ; he was not so sure that the engineering Professor ought to be equally thankful to the Author. He himself found that the amount of supervision and preparation involved placed a burden of considerable care on the shoulders of the Professor. But in drawing a distinction between the laboratories in this country and those in Germany, it

Mr. Wicksteed.

Professor  
Unwin.

Professor Unwin. ought to be borne in mind that in the German Polytechnics there was a very large number of students, and possibly it was because of the large number of students that a different method was there adopted. The Author had given a plan of an excellently arranged laboratory, and it would, he thought, add greatly to its value if he would state what number of students, employed in the way which he thought desirable, could be simultaneously and usefully engaged in a laboratory of that kind. He did not mean in demonstrations, or merely taking the maximum number of men who could be possibly employed at each machine; but taking the hazards which occurred in a laboratory of that character, the chances of specimens not being ready, and other accidents, what would be the normal number of men who could well be employed in a laboratory of the size described? Apart from other subsidiary divisions, the Paper might be divided into questions respecting the strength of materials, and the question of dealing with the steam-engine. He would deal only with the former. And first he desired to say a word with regard to the statement in the Paper as to the Watertown machine, to which he thought the Author had hardly done justice. He believed he had seen in American periodicals drawings of the machine so detailed that it would be quite possible to reproduce it in this country if necessary. The Author had spoken of the difficulty of calibrating the Watertown machine. But Professor Unwin thought he had read how, in the initial stage, that machine was tested by dead-weights precisely in the way in which the Author's own machine would be tested, and he thought there was no more difficulty in the one case than in the other, although his opinion was that no testing-machine so little wanted independent calibrations as the Watertown machine. At all events, after carefully studying the details of the machine, he thought that it was not only by far the largest testing-machine in the world, but by far the most accurate; and the only objection which he could see to the use of a machine of this type, in an ordinary mechanical laboratory, was that it would be at least double the cost of ordinary machines. There was another point about which he thought there had been some misconception. The Author had described machines in which the pull at one end was applied by a hydraulic press, and machines in which it was applied by worm-gearing, and he countenanced the idea that worm-gearing was better adapted to elastic experiments, holding the specimen more firmly than the hydraulic press. His experience was altogether the reverse of that. He had found that the hydraulic press held the specimen

in the machine as steadily and as long as any worm-gearing. Of course the movement of the specimen, if held by the hydraulic press, could only be by a leakage at the cup leathers; and the whole leakage of that kind did not, he thought, amount to an ounce in twelve months. He did not think there was a particle of advantage in worm-gearing over the hydraulic press, and, in convenience, no doubt the hydraulic press had the advantage. He had to consider, at one time a great deal, the advantages of vertical and of horizontal machines, and he agreed that for very long specimens the horizontal machine was the best; but the Author had left out of view what he thought was the special advantage of the vertical machine if it was not wanted for testing excessively long specimens. He could test specimens 6 feet 6 inches in length without making the machine cumbersome. The vertical machine had the advantage that, between the knife-edge of the measuring part and the specimen, no slide was interposed. In that respect, if it was not wanted for testing very long specimens, the vertical machine had a distinct advantage. Of course the friction of the slide could be made very small, but it wanted watching. In testing, everything depended upon the accuracy of measurements, and a good deal of the Paper was occupied with a description of the measuring instruments to be used with testing-machines. The Author had laid down, as a sort of rule, that he had not found measurements beyond  $\frac{1}{10,000}$  inch to be practically very serviceable. In measuring the ultimate extension of a ductile material, like steel, a carpenter's two-foot rule was accurate enough for the purpose; but in taking measurements within the elastic limit a very different state of things had to be dealt with, and he did not think that engineers generally had any idea how accurate measurements within the elastic limit must be to have any value. Taking a very favourable case, a bar 10 inches long, and an experiment to determine the modulus of elasticity between a stress of nothing and of 10 tons to the square inch, an error of  $\frac{1}{10,000}$  inch in the measure of extension would mean an error of 2 per cent. in the modulus. In trying to determine the extension from ton to ton an error of  $\frac{1}{10,000}$  inch would make an error of 20 per cent. in the extension per ton, and he thought that was a larger error than ought to be permitted in a measurement if there was any way of getting rid of it. When he went to Cooper's Hill, he had to look out for some instrument to measure strains within the elastic limit, and he thought he was pretty well acquainted with most measuring instruments. Of instruments for measuring within

Of Professor  
Unwin.

Professor  
Unwin.

$\frac{1}{10,000}$  inch there were very few which he thought could be used. In some the means of measurement were accurate enough, but the mode of attachment to the specimen was bad in the extreme. He wished to point out why it was that the mode of attachment of the measuring instrument to the specimen was so important. He might take a case, which occurred constantly, where there was a certain amount of curvature in a bar. When the stress came on, and the bar straightened, the straightening of the bar introduced an error. Supposing the bar to be bent to a radius of 50 feet, supposing it to be bent till it made a versed sine of  $\frac{1}{30}$  inch in 10 inches (a bar with such a curvature would, he thought, be rejected, but it was not beyond the line of curvatures that might possibly occur), if the bar was measured exactly on the axis, the straightening of the bar would introduce an error of 0.00012 inch. But it was not generally possible to measure on the axis of a bar. The best that could be done was to measure on two points of the surface of the bar. If the two points were on the surface of the bar, then an error would be introduced of 0.001 inch; but usually the measuring instrument was at a considerable distance from the surface. In some cases the measuring instrument was at a distance of 2 inches from the axis, and if that were so the error introduced into the measurement would amount to 0.004 inch. Supposing the instrument to measure to  $\frac{1}{10,000}$  inch, an error would be thus introduced of 40 units on the scale. An error of that amount might not at first sight appear very serious, but the whole extension of the bar within the elastic limit was only 0.007, so that by measuring on the surface the error would amount to one-seventh the whole extension within the elastic limit, and measuring 2 inches away from the axis it was half the extension within the elastic limit. Another cause of error was in the mode in which the bar was held in the machine. If the tension did not pass along the axis of the bar, but on one side of it, a curvature was produced by the action of the stress, which falsified the measurements in the same way. Nearly all instruments which he had seen for measuring the extension of test-bars failed in the mode in which they were attached to the bar. Those beautiful and admirable instruments of the Author's, with a lever arrangement, seemed to fail a little in that respect. The first instrument, which he thought really met the requirements of accurate measurement within the elastic limit, was an instrument invented nine or ten years ago by Bauschinger, which the Author had described, an instrument in which an attached piece rotated a smooth roller carrying

a mirror, and by means of a telescope the rotation of the mirror could be read on a scale. From the first Bauschinger appreciated the importance of the influence of that curvature, because he used two mirrors and two rollers, and it was obvious that if the measurements were made simultaneously, the plus error on one side would compensate for the minus error on the other, and thus the errors due to curvature would be entirely, or almost entirely, got rid of. But a difficulty occurred in that case. It was necessary to have two measurements for each extension, to adjust two instruments on the bar, and in ordinary use in the laboratory that was a somewhat difficult matter. The Author had attributed to Professor Gollner the use of a finger with the roller, instead of a mirror and telescope and scale. In the original description of the Werder machines, which contained a description of Bauschinger's apparatus, there was a roller and finger, and in Bauschinger's Papers, at various times during seven or eight years, there were repeated instances of the use of the roller finger, and vernier, with which Bauschinger appeared to be able to read to the  $\frac{1}{50,000}$  inch, so that he imagined that the Gollner instrument described in the Paper was really Bauschinger's. Professor Unwin had endeavoured to get over the difficulty of having double readings, without sacrificing the accuracy which Bauschinger obtained; and a series of instruments, which he had placed upon the table, were designed to effect that object. In all these instruments the bar was gripped by two clips, each with two steel points, one point being on each side of the specimen, and the four points being in the middle plane of the bar. Obviously, if from any straining of the bar, or any unequal compression or extension of the two sides, there was a difference of extension or compression on either side, the middle point of the clip took the average readings on the two sides. In one of the instruments these two clips were arranged with a micrometer screw between. There was an extremely sensitive level on each of the clips, and by a set-screw the lower clip was set to be exactly horizontal, and then, by means of a micrometer screw, the upper clip was set to be level. Then the micrometer screw gave the distance between the two clips parallel to each other, and the measurement by the micrometer screw was virtually the measurement of the axis of the bar. In that way the difficulty of the micrometer screw was overcome, which was that different amounts of pressure might be put on the screw, and so differences of reading obtained. By having a constant weight resting on the micrometer screw there was no difference of pressure on

Professor  
Unwin.

Professor the screw. The instrument before him gave readings to about  
Unwin.  $\frac{1}{10,000}$  inch. In another instrument he had adopted the principle of the roller and mirror, but he had the roller at the centre of the clip, and he had therefore only one mirror. The clips were spaced apart by a distance-piece on a knife-edge, and the centre of the roller was at the same distance from the distance-piece that the centre of the set-screws was, so that the movement of the roller was identical with the movement of the set-screws; thus with one reading the same result was obtained as Bauschinger got with two readings. There was another instrument for measuring the compression of stone, in which the same principle was carried out in another way. The lower clip was attached rigidly by four points to the stone, so that the end of the lower clip had a fixed position with reference to the horizontal plane near the bottom of the stone. The upper clip was attached to two points near the top of the stone, and as the stone was compressed the upper clip moved upward relatively to the lower clip, and the movement could be read by means of a micrometer. He was one of the first in this country to believe in the value of autographic diagrams, in connection with testing-machines, but he was not sure that too high a value was not now being assigned to the autographic diagram. Some persons appeared to have an idea that there was such a thing as an absolute diagram for a material, and that if from the same material two different diagrams were obtained, one of them must be wrong. That was not his opinion at all. Any number of diagrams might be obtained from the same piece of material. Fig. 24 showed a series of diagrams taken with his machine from pieces cut from a bar of wrought-iron. It would be seen that there were four different diagrams, and he did not believe that one diagram was more accurate than another.<sup>1</sup> One was an ordinary diagram for the straightforward test; two others had been taken with four and six minutes' pauses, and a similar

<sup>1</sup> Reduced results for the four bars shown by Fig. 24:—

No.	Tons per Square Inch.		Elongation per cent.
	Elastic Limit.	Maximum Load.	
319	12·97	22·19	34·7
154	14·37	22·10	25·8
313	13·68	22·34	29·5
314	14·23	22·47	28·2

diagram had been taken from a bar half the length of the others. If considerable differences could be produced by pauses of four minutes' duration, it was obvious that that part of the diagram was not absolutely correct. In three cases it would be observed that there was a marked breaking-down point, but in the shorter bar the breaking-down point nearly disappeared. There was nothing essentially characteristic of the material in the extent or size of the breaking-down point. Getting beyond the elastic limit, Professor Unwin.

FIG. 24.

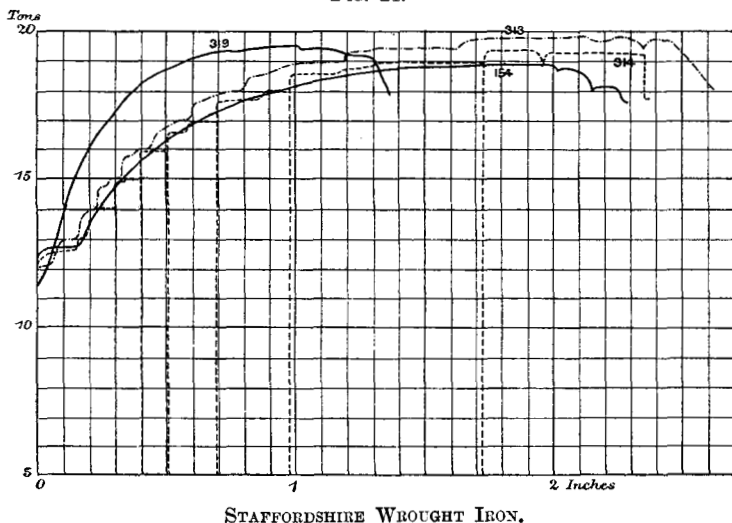

Bar 319, extensions in  $\frac{1}{4}$  inches, the other extensions in  $\frac{1}{8}$  inches. Bar 313, four-minute pauses at each ton. Bar 314, load taken off at each ton, and a pause of about six minutes.

he believed there might be very different forms, and the differences might be simply time differences. He thought the tendency was towards the point at which a good deal more attention would be devoted to what happened before the breaking-point began. Hitherto too much attention had been paid to extension beyond the elastic limit, and he thought a time was approaching when extensions which occurred within the elastic limit would be more carefully examined. Unfortunately, under ordinary modes of proceeding, the observation of extensions within the elastic limit not only involved the use of a rather delicate apparatus, but wasted a good deal of time. Fig. 25 was a diagram taken by a machine which the Author had mentioned—the semi-automatic

Professor machine—by which the extension could be telegraphed electrically, and it showed what kind of diagram was obtained. A step was produced at every  $\frac{1}{5,000}$  inch extension. The steps could be divided into tenths, so that it was possible to read to the  $\frac{1}{50,000}$  inch.

FIG. 25.

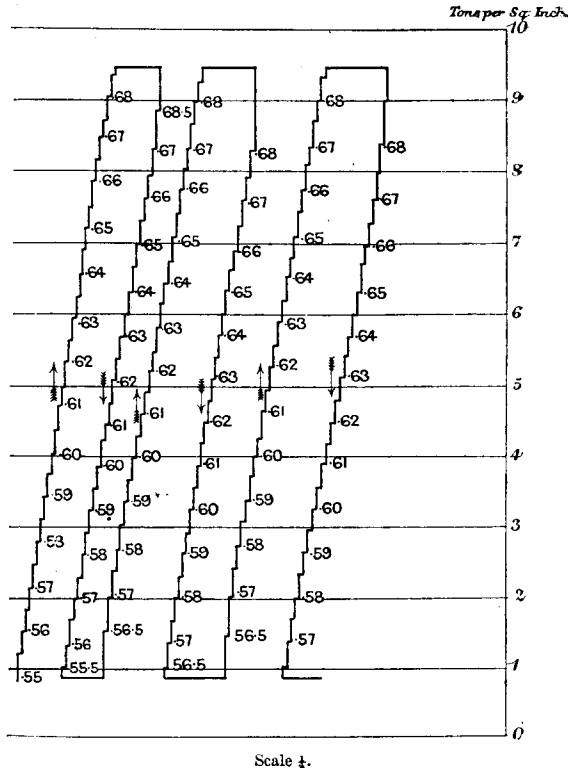

PLATE OF STAFFORDSHIRE IRON, No. 351.

Area  $3.192 \times 0.362 = 1.155$  square inch. Step at each  $\frac{1}{5,000}$  inch of elongations.

Professor Smith. Professor ROBERT H. SMITH observed that the Paper contained much information gathered from many sources wide apart, and such as would remain always useful to those establishing, and those in charge of, engineering laboratories. Besides information concerning existing laboratory apparatus, it contained many useful suggestions for future development. He had always thought that

laboratory work was of prime importance in the college education of engineers, and in his own teaching he had found it very advantageous. The pressure of those non-technical but absolutely essential subjects, viz., mathematics, physics, and chemistry, made it impossible for most students to spend time in the laboratory, to such an extent as to enable them to obtain first-hand experimental knowledge of nearly all matters that they ought to study thoroughly in that way. To the Author's list of subjects appropriate for laboratory study he would add—(1) joints soldered, brazed, screwed, riveted, and pin; (2) hardening and annealing steel and other metals; (3) synthesis of alloys to obtain various degrees of given characteristics; (4) plasticity of metals at various temperatures; (5) strain increasing with time in metals and other substances under heavy stress; (6) earth-pressures; (7) wind-pressure; (8) conduction of heat through surfaces and through plates; (9) the thermal properties of steam; (10) condensation of steam by contact with surfaces. Of these subjects:—(4) was to be studied at the forge by means of positive measurements of forces and strains. (5) was extremely important, and unfortunately very greatly neglected. He might mention the cataract-clock arrangement which was used in his laboratory for obtaining automatically drawn time-strain diagrams. (6) The mathematical investigation of earth-pressures was difficult, and when accomplished seemed very unsatisfactory. It was a very easy subject to experiment upon, and one of extreme importance to civil engineers. (7) was also of the greatest importance, and when the laboratory was provided with a moderately large fan, it was possible to arrange a large number of most interesting and instructive experiments. He had used a method suggested by Mr. Baker for his experiments on the Forth Bridge. (8) (9) and (10) were of course subsidiary to the study of steam- and other heat-engines; but tests of boilers and engines themselves would never supply the detailed experimental information necessary as the basis of the analytical theory of the boiler, engine, and condenser. It was greatly to be desired that special apparatus should be arranged, with which students could experimentally investigate those all-important fundamental laws under the widest possible range of condition, and on a scale sufficiently large to justify the application of the results directly to the practical problems of design. Combustion of fuel ought to be studied most carefully and accurately under the most varied conditions, not on the minute calorimeter scale, but in the furnaces of boilers themselves. For that study a simple and trustworthy pyrometer was very much

Professor  
Smith.

Professor  
Smith.

needed. Of existing pyrometers most were utterly unreliable, and all laboured under the defect that they assumed an enormous theoretical extension of a strictly empirical law, beyond the very short range over which it could be demonstrated by independent experiment. He had been struggling at that problem for several years. He exhibited a pyrometer which had been the result of some years' experiment, and he did so because it had failed. The main idea of the pyrometer was to measure the pressure of a certain quantity of air as the temperature rose. It was a tube to the end of which was attached a pressure-gauge. The volume of the air whose temperature rose and whose pressure rose did not remain constant. The vessel containing the air expanded in consequence of its rise of temperature and the rise of pressure of the air inside. Also, the pressure-gauge had to be kept outside and cool, and it of course contained part of the air. Part of the tube had also to remain cool. Therefore the hot air in the furnace compressed the cooler air in the other part of the instrument, so that the hot air expanded to a small extent. Those furnished three items of correction which practically gave a straight line. The instrument, so far as its indications were concerned, was practically reliable. That, he believed, was the true principle upon which to construct a pyrometer. He had diminished the volume of cold air, to as large an extent as possible, by blocking up the tube all the way down to the hot part, by a rod carefully turned to fit exactly the inside of the tube, a very small groove being cut alongside the rod in order to establish pressure communication between the hot part and the pressure-gauge. Hot joints were altogether abolished, and there was only one welded joint. There was some doubt whether gas did not actually pass through steel at high temperature and at high pressure. The steel of the tube was the densest that could be got—cold drawn steel. After working satisfactorily for some time, the instrument had failed in a mysterious way. It was always cooled carefully and gradually, but it was found over-night that the pressure-gauge had gone suddenly down, thereby demonstrating that some microscopic flaw had suddenly developed, which was sufficient to destroy the instrument. He had not yet obtained any means of getting over that difficulty. He would suggest a pyrometer made of two bars of exactly equal dimensions, laid side by side, bound together at the furnace end, and loose at the cool end, the metals being very slightly different in composition. The difference of elongations, read by the help of a vernier and a microscope, would be taken as proportional to the increase of temperature. The measure-

ments of the strains of a boiler under test, either hydraulic or steam, were of great educational value to students. The hydraulic test was, of course, more convenient for that purpose, because it allowed access to all parts of the boiler. In the chimney there was a mercurial thermometer, the bulb of which lay centrally in a perforated piece of steam-pipe. A very thin sheet of copper was brazed over the perforated portion to protect the closed bulb from direct contact with flame or hot gas. A similar arrangement was used in taking the in- and the out-flow temperature of the surface-condenser. Close to the condenser the pipes were drilled, and pieces of perforated pipe screwed in, the pipes being plugged at the end, covered with thin sheet-copper and filled with mercury. A thermometer dipped in the mercury reached a steady temperature in about a quarter of a minute. He set great value upon the existence of a large 100-ton machine for stress and strain in a laboratory, but if he had to choose between a dozen 10- or 20-ton machines for different classes of tests without the large one, and a 100-ton machine without any small ones, he would decidedly choose the former. One reason for that opinion was that he had no great faith in the practical utility of testing materials to destruction, or even more than, say, half-way towards destruction. Before practical engineering could lay claim to be called scientific, engineers must abandon the barbarous fashion of designing with the help of breaking-stresses, divided by so-called factors of safety. The distribution of stress was, in nearly all structures, extremely complicated and uncertain, and difficult to calculate. He thought that those obscure problems of distribution of stress under moderate average stresses, such as occurred in the ordinary working life of machines and structures, were those which needed most to be attacked in a scientific engineering laboratory. Such investigations would be of incalculable benefit to practical engineering science. The comparison made in ordinary testing-machines between strain and small applied forces was, of course, of fundamental importance; but he could not see any practical utility in finding the breaking-load. More especially was that useless when details as to time-rate at which the load was gradually increased to the breaking-point were not supplied. To find the stress-distribution the strain-measuring apparatus must be of extreme delicacy, and often of great complication. Surface strains might be measured by direct means. He did not know how internal strains could be measured; but he did not despair of satisfactory means of doing so being eventually discovered. His own speculations in the matter tended towards the use of electric or electro-magnetic

Professor  
Smith.

Professor apparatus. In Mason College workshop, a good many small Smith. testing-machines had been made for various purposes. A Salter's spring-balance, indicating up to 9 tons, was used in one instance, and was quite satisfactory, except that the ordinary rack-and-pinion gearing should be replaced by a fine wire and pulley connection. In a lever machine used chiefly for struts and beams, the lever knife-edge was thrust downwards by a pair of right- and left-hand screws gearing with nuts formed into worm-pinions. Those worms were driven by right- and left-hand worms keyed on the same spindle. By that arrangement there was no end-thrust on the collars of the worm-spindle, and the friction of the gearing was thus considerably reduced. A third machine was used for bending beams up to  $\frac{3}{8}$  inch by 1 inch section, the force being measured by a spring, the compression of which was read by means of a vernier scale. That used to be, and perhaps still was, the method used in Sir Joseph Whitworth's works to test the quality of specimens of his well-known steel. Various other machines had nothing special of mention; but apparatus was often rigged up temporarily by the students themselves for special purposes. He thought that those experiments, made without special machines, were quite as instructive to students as those made with elaborate and expensive apparatus. For instance, the measurement of the deflections all along the length of a beam of channel, T or I iron 10 or 20 feet long, and loaded in all possible different ways, was far more educational than the breaking by tension of a bar either large or small. Such a beam placed over different numbers of supports, the pressures on those supports being accurately measured under different systems of loading, gave again a most interesting form of experiment. A large piece of plate- or sheet-iron placed horizontally, supported along various portions of its edges, and loaded in various manners with concentrated and distributed loads, was another kind of investigation attempted by his students, the deflections over the whole surface being carefully mapped out. His students in that sort of work had not infrequently shown a gratifying ingenuity in the construction of the details of the apparatus they had made for their own use. He might instance forms of disengaging-hook for letting fall weights on specimens of material, and means of measuring the momentary deflection of beams struck by falling weights. He exhibited an apparatus for testing pressure upon cutting-tools in lathes. An ordinary tool-holder was extended so as to form a lever, and was pivoted on a small pin in a block clamped in the ordinary tool-rest. In the tool-rest above and

below the lever were placed two parallel strips of steel. These were feelers, and the lever was loaded: the weight of the whole apparatus was carefully balanced by a spring. The weight was moved along the levers until the exact pressure was obtained, as tested by both feelers being equally easy to slide to and fro. By the use of the feelers all chattering was eliminated. If the weight was moved along the lever the least bit too much ( $\frac{1}{32}$  inch was sufficient), the lower lever felt tighter than the upper; and if it was not moved along far enough, the upper feeler was the tighter. By that means pressures up to 1,000 lbs. could be tested with an error of no more than 4 lbs. His pupils also tested the frictional efficiency of the different machine-tools in the workshop. A most useful set of experiments made by them had been the statical friction between pulleys and belts. The coefficient of friction seemed invariably to decrease as the pull increased; it was less for leather than for cotton; including the effect of belt-stiffness, the variation of diameter of pulley seemed to have little or no effect with single-thickness leather belts, but with double-thickness the decrease of the size of pulley made a marked difference in the frictional coefficient; and that coefficient increased with the thickness of the belt, other things being unaltered. In a machine he used for testing journal-friction, equal pressures were put on opposite sides of the journal by a strong spring, enclosed in a large iron tube and pushed forward by screw- and worm-gear. The whole of the weight of the apparatus was suspended by a link to the apparatus exactly over its centre of gravity, and that link was pulled upwards by means of a lever, and a weight adjusted until the nicest balance was obtained. The moment of friction was balanced by the two pulls at the two ends of one piece of wire; the one end pulled upwards at 5 inches on one side from the centre of the pin, and the other end of the wire pulled downwards at 5 inches on the other side, passed over a pulley underneath, over another pulley a little further along, then upwards and over a third pulley which was attached to the end of a spring-balance. The two pulls upwards and downwards were exactly equal, and they were measured by screwing up the spring-balance. The equilibrium was tested by the vibration of the lever, mentioned before, and the moment of friction could be measured to within an inch-pound. The specialty of that machine was that no bending-moment was put on the journal. That ensured symmetry, and a probable uniformity of distribution of pressure along the length of the bearing. He might remark in that connection that making

Professor  
Smith.

Professor a machine for testing journal-friction so stiff, that its deflection under any bending moment that might come upon it would be very small, did not eliminate the variation of the intensity of the pressure along the length of the pin, because extremely minute deflection might mean a great variation of intensity of pressure. He wished to make a similar criticism of machines for testing the torsion, stiffness and strength of shafts. A machine of that sort should have all the bending-moment eliminated. With regard to large testing-machines, the only point of advantage he could find, in the vertical over the horizontal design, was that the scale of the former could be tested directly by the application of dead-loads in place of the test-piece. The Author did not explain the method adopted in testing the lever-scale in horizontal testing-machines. In consulting over the design of a 100-ton horizontal machine for Mason College, he was informed that the ordinary practice was to supply extra bell-crank gear to be attached to the test-piece end of the machine for the purpose of this checking of the scale. That seemed to him very unsatisfactory, because the accuracy of the test would then depend upon the correct measurement of the dimensions of the auxiliary bell-crank lever; and it seemed as rational to rely upon careful measurement of the dimensions of the levers of the machine itself, as upon that of the similar sizes of the auxiliary lever. It was decided that a better plan for testing the scale would be to use a spring, previously calibrated carefully by the application of dead-load. If the decision were right, did it not follow that the best type of horizontal machine would be one in which a powerful spring would be the means of measuring the force? Such a spring could be made for a 100-ton force, and could be made compound, so as to give a large scale of deflection for small forces, and a small scale for large forces. The spring would be calibrated up to its maximum force in a single-lever vertical machine like Wicksteed's. Time did not permit him to do more than refer to a rotary transmission-dynamometer, which he exhibited; to two new forms of friction-brake dynamometer; and to the appliances and methods used in connection with his experimental boiler and engine.

Professor Shaw.

Professor HELE SHAW said that allusion had been made in the Paper to a form of apparatus for drawing diagrams of stress and strain, designed some time ago by himself; and the Author had truly said that it was in its essential principles identical with those of Mr. Aspinall and Professor Unwin. There were, however, certain features of novelty about it which might make a brief description of it interesting to the members. With this view, and



Professor  
Shaw.

directly proportional to the stress on the test-piece  $t$ . The strain was recorded in the usual way, one end of a wire,  $w$ , being attached to one of two points on the test-piece, passing over the pulley  $c$ , and finally to a small pulley on the same spindle as the large pulley  $m$ . Another wire passing over the larger pulley  $m$  carried the recording pencil  $k$ , tension on the wire being maintained by a suspended weight shown above  $k$ . There were thus two motions at right-angles to each other, the motion of the barrel about its axis, which gave a measure of the stress, and the motion of the pencil up and down, which was the measure of the strain. The side view, Fig. 27, showed how the jockey-weight cleared the apparatus, and showed the barrel in position. The diagramming apparatus was extremely simple; it was made by the students of University College, Bristol, at a cost of a very few shillings. It might at first be thought that the possible stretching of the cord might lead to an incorrect result; but no one would think so when reminded that the cord travelled 15 feet with a 6-inch travel of the barrel, and therefore any possible error from this cause was reduced thirty times by that means. As a result of a large number of experiments, he had absolute faith in its records. There was no arrangement for measuring the absolute motion of the whole test-piece. He had not detected any movement of the kind, and it was not measured in most pieces of apparatus of that kind.

The Author deserved the thanks of the whole engineering profession for what he had done in the direction of securing a proper recognition of the value of engineering laboratories; and, after some experience, Professor Shaw wished heartily to endorse what he had said as to the true function of an engineering laboratory being the education of the students themselves. Any one, who had taught the average engineering student to make measurements for the first time, would be convinced of the value of such instruction as a well-conducted laboratory could afford. There should be a happy mean, between the entire devotion of the Professor and advanced students to original work, and a stereotyped process of making measurements and calculations. He was at a school where surveying was taught, and there was a large bare piece of ground on which the field-work was done, and instructions were always given for the poles to be put in the same holes, which saved a good deal of trouble to the teachers and also to the boys, for they had in addition, for the purpose of facilitating calculations, a traditional book handed down to them. He thought that kind of thing might happen in an engineering

laboratory without careful watching and attention on the part of the Professor. Professor Shaw.

When he was appointed to the chair of engineering at Liverpool a year ago, so convinced was he of the importance of an engineering laboratory, that he immediately began to ask for money to establish it, pointing out that without such a laboratory there was no possibility of establishing an engineering school. Now, thanks to the munificence of one of the citizens of Liverpool, there was about to be built a structure, with equipment, which would cost £15,000. In conclusion, he would only direct attention to a long and valuable monograph, by Captains Denizéau and Lechien, on machines for testing metals.<sup>1</sup> It had been abstracted and printed in the Minutes of Proceedings,<sup>2</sup> and would be found of use to those working on the subject.

Professor ARCHIBALD BARR thought that the method of working laid down in the Paper was practically perfect, except perhaps that a little more attention might be given to original work on the part of the most advanced students than was suggested. As to the different testing-machines, he thought that there was very little choice, between the Wicksteed and the Greenwood machines, with regard to accuracy and convenience for ordinary purposes. In considering the suitability of those machines for the Yorkshire College laboratory, he was very much influenced by the circumstance that had the Greenwood machine been adopted, it would have required to have been placed down the longest stretch of the laboratory, and across the cart-way entrance; whereas the Wicksteed machine could be more conveniently placed, and only occupied a space of about 3 feet square upon the main laboratory floor. He also thought that, for teaching purposes, it was of considerable importance to have the specimen exposed to view, during a test, as clearly as possible to a large number of students. That object had been secured in the machine at the Yorkshire College more than it could usually be in the case of the Wicksteed machine, because it had been possible to place the pumps out of the way on the floor of the lower laboratory. The Author had made some remarks with regard to the position of the scale in horizontal machines. No doubt it was very important to have the scale upon a level with the eye; but he might point out that in the Wicksteed machine, the scale being very much longer Professor Barr.

<sup>1</sup> "Monographie Raisonnée des Machines à essayer les Métaux." *Mémorial de l'Artillerie de la Marine*. Vol. xi. (1883) p. 311, and vol. xii. (1884) p. 17.

<sup>2</sup> Vol. lxxvii. p. 390, and vol. lxxx. p. 352.

Professor Barr. than in the horizontal machine, the defect referred to was to a large extent counteracted. With regard to the special features of the Yorkshire College machine (p. 19) the machine had been constructed of exceptional height, principally with a view to the testing of long specimens in tension, not with regard to tests in compression, as the Author seemed to think. He considered that it was especially for tension tests of long specimens that the vertical had an advantage over the horizontal machine, on account of the avoidance of the sag of the specimen. In that respect he differed from Professor Unwin. With regard to testing long struts, he thought that the weight of the strut itself would in many cases materially influence the buckling, though in many other cases the amount of that influence might be neglected. Professor Smith had spoken of the value of testing within the elastic limit as compared with testing to breaking. Professor Barr desired to express his opinion strongly on that point. That was one reason why he would say that a machine should be made to take in long specimens. By testing a specimen 100 inches long measurements of a tenth part of the delicacy required in a 10-inch specimen would be sufficient; or, making the measurements as delicately, the results would be ten times as accurate as those obtained from the small specimens. That, of course, had reference only to scientific testing. As to the work to be done in a testing-machine, it was necessary to remember from the outset that there were two purposes for which tests might be made. One purpose was to determine the qualities of a particular specimen of material, the other was to determine the characteristic properties of a material. With regard to testing for the purposes of instruction, it was of very slight importance indeed for a student to know that a particular specimen of steel sent in upon the 10th of January by John Smith and Co. behaved in such and such a manner. What it was really necessary to instruct the student in, was the characteristic properties of materials, and the effects of different kinds of treatment upon them. In regard to initial stresses in the material, the form of the piece, and the method of loading, any test made in a laboratory would have only a very remote connection with what occurred in general practice. A small specimen, for example, cut out of a connecting-rod was a different thing from a connecting-rod with its welds, and so on. The results, therefore, of any one test such as those given in Fig. 11, gave a great deal of information which was not characteristic of the material, but characteristic of the particular specimen tested, of its particular form, and of the method of applying the load. In that con-

nection he differed from what the Author had said with regard to Professor Barr. wire-testing. He had compared wires with ordinary specimens. Professor Barr should make the comparison the reverse way. In the case of some wires—annealed wires, for instance—if they differed from an ordinary specimen it would be in their having greater homogeneity. Wire-testing had the further great advantage that a large number of practically identical specimens could be tested. In testing with a small machine represented in Fig. 28 (p. 106), different wires cut from one coil, if two drawings were made upon one paper under like conditions, with a fine pen, they often agreed so closely that one line was for a considerable part of the length not distinguishable from the other. Another advantage was that any particular condition might be varied; the wire could be tested quickly or slowly, Figs. 29 (p. 107), and where a considerable difference was found it would be known that was due to the method of testing. The material might be given rests, Figs. 29, more conveniently than could be done with specimens in a large machine. Besides that, in testing wire, experiments could be made which were practically impossible, or very troublesome, in a large machine. For example, the stress might be applied at the rate of a ton per square inch per hour, or per month. The results obtained were exceedingly interesting, because it was certain that almost the whole of the measurable difference of results on the diagram was due to the different treatment, and not to any difference in the specimens themselves. For that reason he thought that a great deal of valuable information could be obtained from testing wire. With regard to torsional testing, he had made some experiments with an improvised machine, and they had been very interesting because the machine could apply the twisting moment in both directions. That, he thought, should be a characteristic of every machine for scientific work in torsional testing. He had found that by twisting a rod continually in one direction its elastic limit could be raised three or four times as high as by twisting it backwards and forwards. That had a great bearing upon the recent work done by Wöhler, Bauschinger, and others. Very valuable information was to be obtained by tests of that kind. Fig. 30 (p. 108) represented Denison's testing-machine for light loads. The upper part *a* of the standard carrying the steelyard was raised by means of a screw, worm-wheel and worm, actuated by the hand-wheel *e*; the rod *d* was attached to the rear pivot of the steelyard and rose with it, exerting an upward pressure upon the centre of the specimen *g*, which was a cast-iron bar 2 inches by 1 inch, held at points 3 feet apart. The free end of the steelyard

Professor Barr.

Fig. 28.

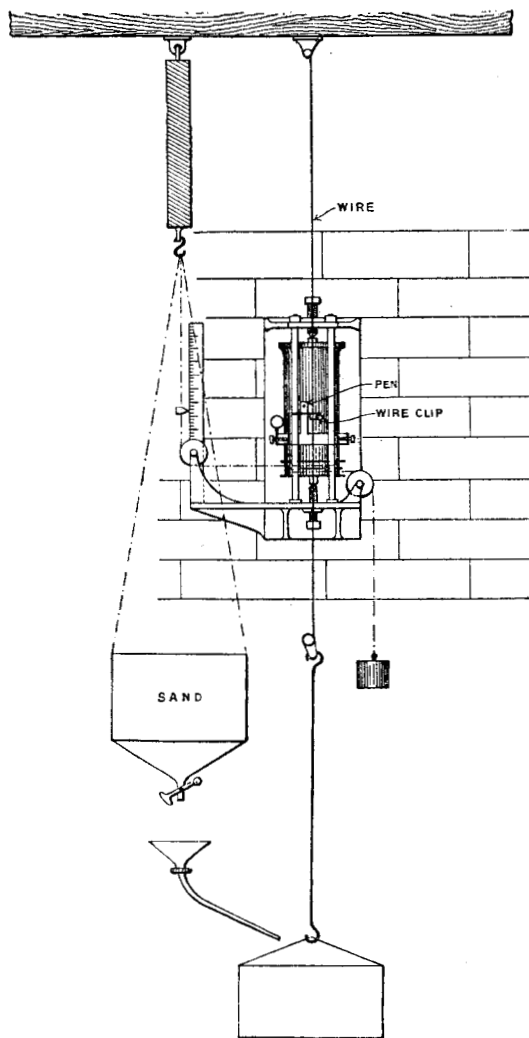

WIRE-TESTING MACHINE.

Professor  
Barr.

FIG. 29.

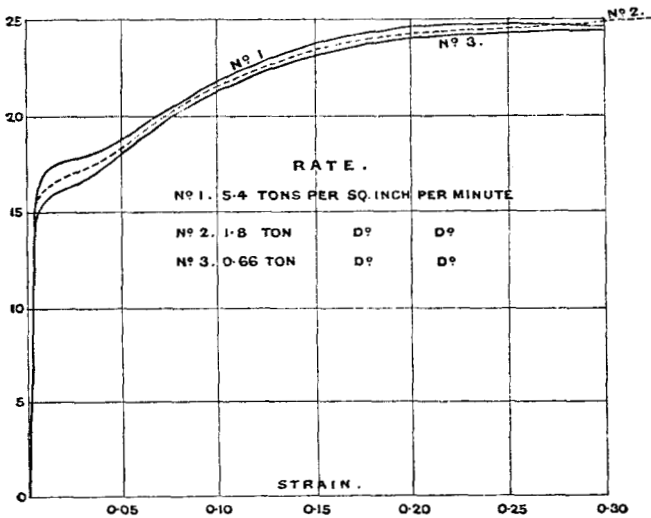
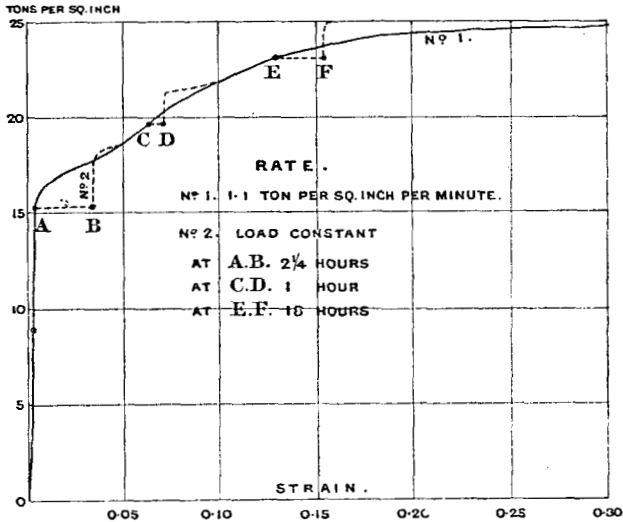

CHARCOAL IRON.

Professor Barr.

FIG. 30.

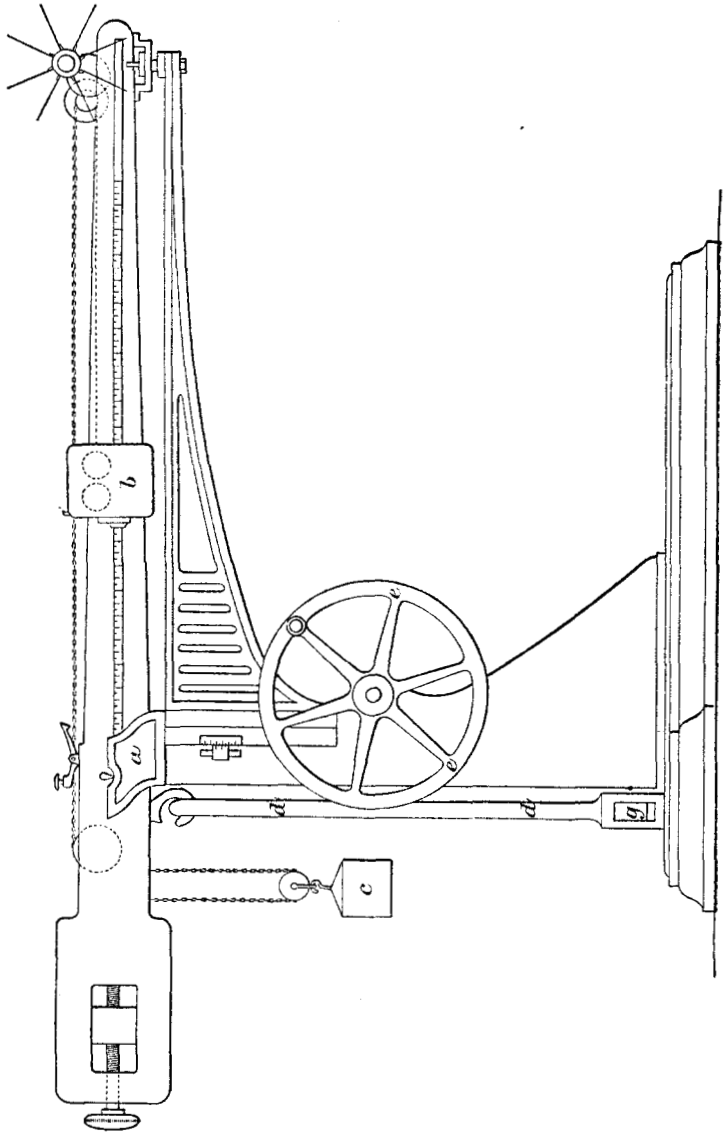

DENISON'S TESTING MACHINE.

carrying the detent wheel was thrown up, disengaging the detent Professor Barr. and allowing the counterpoise  $b$  to run outwards under the influence of the chain and weight  $c$ . When the increased load caused the specimen to bend, the steelyard fell again to the position of detent and more stress had to be applied by means of the hand-wheel before the weight  $b$  travelled further upon the lever. The adjustment of the poise was therefore to some extent automatic.

He wished to add one or two remarks upon engines. As to surface-condensing, a variable quantity of circulating-water should be arranged for, and that could not be easily done if the circulating pump was used. Varying the area of condensing surface would also be very valuable, and varying the air-pump volume would certainly be useful. At the Yorkshire College the experimental engine had been arranged in such a way that the stroke of the air-pump was variable while the lowest volume of the pump was always the same, so that there was no discharge during the alteration except that due to the amount of condensation. The stroke could be varied in a few moments while the engine was running, and two diagrams could be taken almost at the same time with different effective volumes of air-pump. With reference to § (x), p. 47, he thought that instead of altering the clearance-volume by additions to the cover, it would be better to do it by additions to the piston; there would then be a still more close agreement between the conditions of radiation in the two cases. Fig. 31 and Fig. 32 represented two brakes which he thought were comparatively simple; Fig. 31 was sometimes called Carpentier's brake and sometimes Thomson's. It was shown by Professor Thomson to his class some years before it was published by Carpentier, and it was used at the Glasgow Gas Exhibition (1880) for testing on the very day on which a description of it was published in this country.<sup>1</sup> He believed it was the only brake which could apply an absolutely uniform resistance. If the friction was too great the loose pulley was drawn round, unwinding a portion of the rubbing cord from the running pulley, and thus automatically adjusting the resistance. The result was that two weights could be put on, and the brake would work under them for any length of time. He had made experiments with the brake up to 9 HP., using weights of 576 lbs. and 366 lbs., running at 148 revolutions per minute upon pulleys 3 feet in diameter. The brake shown by Fig. 32 was only a slight modification of a very well-known one, the modification consisting in attaching to the ropes wooden connections that passed

<sup>1</sup> Minutes of Proceedings Inst. C.E. vol. lxiii., p. 404.

Professor Barr. down the side of the brake wheel and prevented the ropes slipping off. The friction of these was, of course, measured because it was transmitted to the cords just as if it were between the cords and the pulley. The brake could be improvised in any workshop in a few minutes, and at the cost of a few shillings. He had used such a brake with 156 lbs. at the heavy end and only about 12 lbs. at the other end, and the variation of the reading of the spring-balance might almost be neglected. The Author had spoken of

FIG. 31.

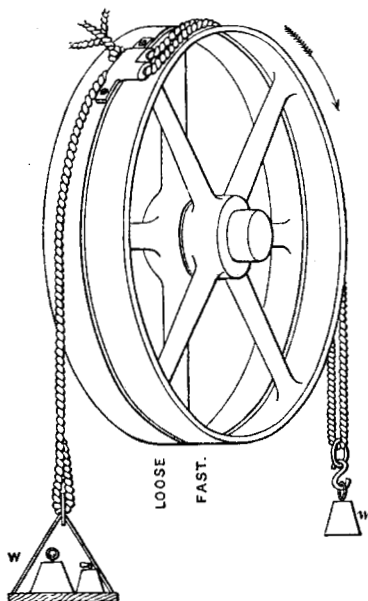
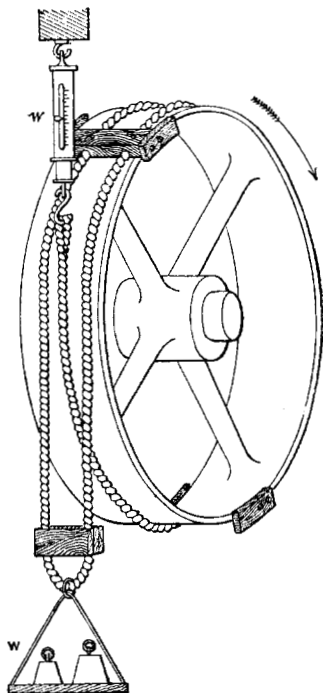

FIG. 32.



the convenience of having two engines. With the Yorkshire College engine it was possible to work either cylinder independently, so that one engine could be under test as a single-cylinder engine while the other was driving the machines. That proved a quite convenient arrangement so far as it went.

Mr. Roberts-  
Austen.

Mr. W. CHANDLER ROBERTS-AUSTEN said that if engineering had not so distinct a metallurgical side, it would hardly be possible for a Professor of Metallurgy to speak upon the Paper. Moreover, mechanical tests of metals and alloys were comparatively value-

less, unless taken in conjunction with the chemical composition of the material tested, so that the relation between the chemist and the engineer was very close. The system which the Author had inaugurated had taken very firm hold of national education. As to the mechanical teaching of young engineers he could speak with very little knowledge, and less experience, because the wants of the students who came to him at the Royal School of Mines were satisfied by enabling them to use a testing-machine represented in Fig. 4, p. 11. But he had a strong opinion as to the great importance of the kind of work advocated by the Author. So strong was it that for many years past he had tried to make metallurgical teaching and mining engineering practical, in the sense that the Author made the teaching of mechanical engineering practical. The result was that, at the School of Mines, the student might have 1 ton or 2 tons of ore given to him, and be told to extract all the metals which it contained. He might find out what were the best methods to employ, and suitable plant was given to enable him actually to extract the respective metals. There was a blast furnace, a reverberatory furnace, a pan amalgamator for silver ores, and a small Bessemer plant. The Americans were devoting most anxious care to the formation of such mechanical and mining laboratories, and the students dealt with ore varying up to 2 tons in amount, according to its kind. He would direct attention especially to the valuable Paper appearing in the Transactions of the American Institute of Mining Engineers, in which Professor Richards of the Massachusetts Technical Institute, at Boston, had pointed out that there were in America no less than thirty-five engineering laboratories more or less resembling those advocated by the Author, and seven mining laboratories. One great value of the Paper under discussion consisted in its removing entirely all misconceptions as to what a mechanical laboratory really should be. It was not long ago that such statements as these were met with: "We must throw out of consideration altogether the toy-workshops of the schools themselves;" "It is a delusion to suppose that requisite mechanical knowledge can be gained in the workshops attached to some of the colleges." "It can no more be learned there than the execution of engineering undertakings can be mastered except by actual experience." "The construction of toy engines with india-rubber pipes and soft solder, and the turning of dinner napkin-rings . . . may be pleasant amusements, but little or no actual knowledge is obtained in the use of tools, the properties of materials, or the business of the mechanical engineer." If the Author would carry his

Mr. Roberts-  
Austen.

Mr. Roberts- mind back twenty years, when they were both students at the  
Austen. Royal School of Mines, and would think of the facilities which  
existed then, and the absolute impossibility of getting anything  
like adequate mechanical instruction, he would have abundant  
reason to be satisfied with the progress which had been made, and  
with his own share in that progress.

Mr. McGregor. Mr. JOSIAH MCGREGOR observed that he had had occasion to study  
in an official capacity the training of engineers. He cordially  
agreed with the Author that it was essential for a young engineer  
to obtain his practical training in the workshop. He could not,  
however, follow the Author in his next remark, "But the practical  
training of the workshop is incomplete even on its own ground,"  
as he believed the training of the workshop was remarkably com-  
plete, so far as it went, and much more complete than the training  
usually obtained in engineering laboratories. The Author went  
on to say, with reference to the laboratory training advocated, that  
it "should at the same time supplement and complete workshop  
experience without overlapping it." In what way it could com-  
plete workshop experience he was unable to conceive; it might go  
a small way towards completing an engineering education, but it  
was not essential to it, like mathematics, mechanics, and other  
branches of science. To consider an engineering laboratory as in  
any way supplementary to a workshop was, he thought, absurd.  
It was really supplementary to a physical laboratory, to which it  
was closely allied. To associate engineering laboratories with  
workshops, in this way, he considered a great mistake. The less a  
laboratory savoured of a workshop the better. The Author asserted  
that, in an ordinary pupilage, a young engineer had not much  
opportunity of studying the physical properties of steel, &c. He  
supposed by the word "pupilage" here was meant apprenticeship.  
Now, in an ordinary apprenticeship, a young engineer, especially  
if he went into two or three different shops, had a great deal to  
learn, which in its way, and as far as it went, was pretty tho-  
roughly taught; and it went at least some way towards giving a  
knowledge of the physical properties of steel, &c. But in addition  
to this, which was the essential training of a skilled mechanic, a  
young engineer must be well trained in the scientific principles  
of his profession, which training was usually obtained at some of  
the numerous scientific institutions throughout the kingdom. A  
good engineering education thus took a long time to acquire, per-  
haps longer than the education for any other profession, and the  
essentials of this education were scientific knowledge on the one  
hand, and practical training in workshops on the other. Where

was this system of laboratory training to come in? He thought Mr. McGregor. it might be safely said that it would not be allowed to interfere with, or diminish the period of, apprenticeship. Therefore it must be accomplished in the period allotted to scientific training, which, if limited as was almost invariably the case, meant substituting it for some of the other more or less essential subjects that should be taken up; and as a laboratory class necessarily occupied a large amount of time, it would in most instances involve a session to itself, that he considered would be much better spent elsewhere. The Author advocated this system of laboratory instruction "for teaching the art of making experiments." This it might assist in doing; but an engineer possessed of the scientific knowledge, and remembering the nature of his practical every-day life, should have little difficulty after perusal of similar experiments, in conducting with the greatest accuracy ever likely to occur. He also advocated this system, to set the student free from the "thralldom of the engineering pocket-book;" but Mr. McGregor believed that the student, who devoted the time thus occupied to ordinary class pursuits, would be in a greater measure free from this thralldom. The engineering laboratories of the Continent were mostly in this respect based on a better principle; they were practically for the use of the Professor, and were used by him for investigation and original research, for which the whole of his time not required for lecturing was available. Being in possession of a laboratory, he was able to illustrate the subject of his lectures, and even to conduct experiments before the students, in quite as effective a way, and with infinitely greater expedition than if they performed them themselves. He considered the Author was incorrect in stating that the object of such a laboratory was "to give the students the opportunity of experimenting for themselves." It should rather be to enable the Professor to bring his subject forward more impressively, as well as to enable him to keep in the fore-front of his profession. No one was more alive to the advantages to be derived at physical laboratories than himself; but to be in a position to derive this advantage necessitated great scientific knowledge, and a comparatively matured judgment, without which it was a great mistake, as well as a waste of time, as it threw away opportunity for ordinary class study at college, which would be invaluable.

Mr. E. A. COWPER observed, in regard to the Author's mode of Mr. Cowper. "causing young men to obtain knowledge for themselves," that he was entirely at one with him, for he believed that the know-

Mr. Cowper. ledge obtained by making experiments and observations was far more useful and enduring than a lecture. A simple chemical fact would illustrate his meaning. If a piece of phosphorus was put into hydrogen gas it produced no particular effect upon it; but if the phosphorus was placed in a medium where the hydrogen was being evolved, the nascent hydrogen absorbed the phosphorus, and became a part of it, and the product was phosphuretted hydrogen. So if a young man discovered a thing for himself, say the details of, and practice with, an indicator, he was no longer one who had simply heard a lecture on an indicator, but he was an "indicator man." His late father, Professor Cowper, at King's College, was always trying to instil into the minds of the men habits of close observation, just as the Author expressed it in different language, the "power of accurate measurement." In a chemical laboratory it was essential that the students should work, and it was just as important in an engineering laboratory. He would be willing to leave the matter there, but as he had had opportunities of trying experiments on a large scale, from 1844 till 1851, and other opportunities since, he would add a word or two on the subject. With regard to heavy tie-rods, he had proved all the links of the Kieff Bridge; these links were 10 inches by 1 inch in section, and extended considerably in the 12 feet 6 inches length between the eyes. It was also found that the softer description of iron—something like cable iron—was not well suited for the purpose, as the links stretched too much, and therefore a rather harder description of iron was selected, having a higher elastic limit. The "extensometer," noticed by the Author, was used throughout, and  $\frac{1}{10,000}$  inch could easily be read, and the first set of the metal determined, which was undoubtedly lower than had before been suspected. One particularly uniform bar, 5 inches by 1 inch, stretched  $3\frac{3}{8}$  inches in 7 feet 6 inches, and, of course, became divested of the black scale throughout the length. He designed a proving machine, having two hydraulic presses at one end acting on a cross-head, and provided with lever arrangements at the other end to measure the strain; but a plunger, with lever and weights on the hydraulic pipe, yielded such exact results, that it was generally used instead of the lever. He thought the excellent plan of automatic registration of results, introduced by the Author, would prove most valuable, and he had no doubt it would be copied in other machines. He had tried numbers of struts for roofs and other purposes in the form of T and L irons, "channel iron," tubes, &c., by end pressure, and it was curious to notice how a strut, that at

first bent into a slightly S curve, would suddenly start into a Mr. Cowper. C curve, and would then, of course, carry very little; and it was also instructive to observe a light cast-iron column first bend slightly sideways and then fly to pieces sideways with great force, due to the end pressure. With regard to experiments on steam-engines, he believed that steam was always damp unless superheated, and for this reason, if for no other, viz., that it rose through a mass of water, and would necessarily be as damp as air would be if that rose up through water; besides this, there was always some radiation going on from the steam-dome, steam-pipes, &c., and this tended to condense the steam. A new "steam-separator" had lately been found very useful in separating water from steam. It was the invention of Messrs. Boys and Cunynghame, and deserved to be experimented on. No doubt a surface-condenser was a most desirable apparatus to have for experiments with engines, and a surface-evaporative-condenser would also be useful as a valuable help in effecting economy of fuel, in many situations where water was expensive. And even with a common injection-condenser, experiments might with advantage be made in employing the whole force due to the vacuum in the jet, so as to make the injection-water break up as much as possible into minute drops in the midst of the steam, and thus use less water for injection, the temperature agreeing with the pressure much more closely.

Experiments on steam-jacketing cylinders, and the "hot pot," in compound-engines were very important; and for obtaining uniform rotary force in a compound engine, it was undoubtedly of the greatest advantage to have the cranks at right-angles, and the cylinders properly proportioned, all which points could be experimented on in the laboratory with a good engine.

Alteration in clearance or steam-space at the end of the cylinder could be effected cheaply by attaching plates to the piston, or to the bottom or top, or, at some greater expense, by altering the length of stroke, by shifting the crank-pins in disks in place of cranks.

In all experiments on friction, he trusted that very heavy pressures per square inch of bearing-surface would be tried, as in practice it was very important to ascertain which were the best materials for the purpose. He thought the exact determination of elastic-limit was quite as important as breaking-weight. Take the simple case of a boiler, if the metal stretched and took a permanent set it was not the same boiler that it was to begin with, and one part might be strained and another not, for it was

Mr. Cowper. impossible in any case to make every part equally strong. If some of the plates were without holes and others with rivet-holes in them, and the rivets took a set, or the plates between the holes took a set, the boiler would leak or fail. He had, therefore, always made boilers to keep within the elastic-limit when proving to double the working-pressure. This at once pointed to one of the great advantages of steel for boilers, as the elastic-limit was much higher in steel than in iron.

Some years ago he had requested Mr. J. T. Smith, M. Inst. C.E., of Barrow, to rivet up a short length of boiler of  $\frac{1}{4}$ -inch mild steel plates, 4 feet in diameter by 4 feet long, and to try to burst it with water; this could not be done, as at 420 lbs. per square inch it leaked all over, the plates and rivets being so tough as to take a set, and stretch so as to cause leakage. This experiment was particularly satisfactory to him, as about this time, the faith of some people in steel was rather shaken, in consequence of some important boilers giving way before use. He wished British manufacturers were more enterprising in trying practical experiments, for on them depended greatly the improvement of manufactures, and the maintenance of their position, as the most advanced manufacturers in the world.

Mr. Stroudley. Mr. W. STROUDLEY agreed as to the great advantage of giving a student engineer a course of work like that described in the Paper, before entering a workshop, where, although the opportunities were greater, the pressure of work did not allow sufficient time for a close investigation of special objects. He had observed that pupils who had had the benefit of that class of training at Cooper's Hill and similar institutions, took more readily to the difficulties met with in a railway workshop than those who had had no such advantage. There must, however, be always wanting in an establishment such as that described in the Paper, the results of wear and tear. The testing to destruction would not determine the best form of a piece of machinery; and it was by observing the breakages and failures that an engineer could decide what was the most fitting for each particular purpose. He had observed a flaw or a crack in a piece of a locomotive, and had noticed from week to week, and from day to day its extension. Iron or any other metal would certainly break by a varying load, although it might be much below the observed limit of elasticity. It was, therefore, in his opinion, of the first importance for a student to learn to be exact in his measurements; and the delicate instruments described in the Paper would no doubt tend very much to exactness, and thus enable students to avoid the mistakes

that were frequently made in the designing of machinery. He Mr. Stroudley. had exhibited two specimens of parts of a locomotive that had broken in the way he had mentioned, and they showed that, although the iron was originally, and was still apparently, very ductile and tough, the flaw would commence and gradually extend down to two-thirds or more of the total area, yet it would not break, proving that there was more than sufficient strength to do actual work, while there was not sufficient to prevent extension beyond the limit of elasticity of the metal. The specimens referred to were cotters of an old-fashioned locomotive with forked connecting-rods. A careful estimate of the reciprocations made by these connecting-rods during the life of the cotters amounted to 50,000,000, the maximum strain by the pressure of the steam being about 13 tons. He had no doubt that very refined measurements, such as described by the Author, would have shown that these cotters had been strained to a certain degree, and although not sufficient to create any visible change of form, it was sufficient to gradually rupture the material.

Mr. C. E. STROMEYER said that as some of his inventions had Mr. Stromeier. been referred to in the Paper, and as these were, he hoped, of interest to the members of the Institution, he would give a brief explanation of one of them. The instrument, of which the main features were shown in Fig. 33, was intended to measure the cross deformation of test-pieces subjected to stresses below the elastic limit, and which rarely exceeded  $\frac{1}{4,000}$  inch per inch diameter. Except to those who were thoroughly conversant with the undulatory theory of light, it would be rather difficult to explain the phenomenon on which the principle of the instrument was based. In physics it was called the interference of light, and it was more generally known by the name of Newton's rings; it could easily be produced by pressing together two small pieces of glass, say 1 inch square, and holding them behind the flame of a spirit lamp or Bunsen burner tinged yellow by salt or other soda salts. If the pieces were cut from ordinary window-glass, irregular black and yellow bands would become distinctly visible to the naked eye, and it would be noticed that by altering the pressure on the glasses these bands changed their shape and relative position. This could be thus explained:—Though there was nothing by which one band could be distinguished from its neighbour, every one coincided with the curves of equal distance between the glasses, just as fathom lines on nautical charts followed the lines of equal depths. Were these fathom lines to be redrawn, as the tide rose foot by foot, they would appear to

Mr. Stromeier. move similarly to the black bands visible on the glasses. In fact, the only differences between the two markings were, that every time when one line had moved so far as to take up the original position of its neighbour, it was a sign in one case that the water-level had risen 1 fathom, while the same motion of a black band signified that the upper glass had moved  $\frac{1}{86.250}$  inch away from the other one. Fig. 33 showed a piece of black glass

FIG. 33.

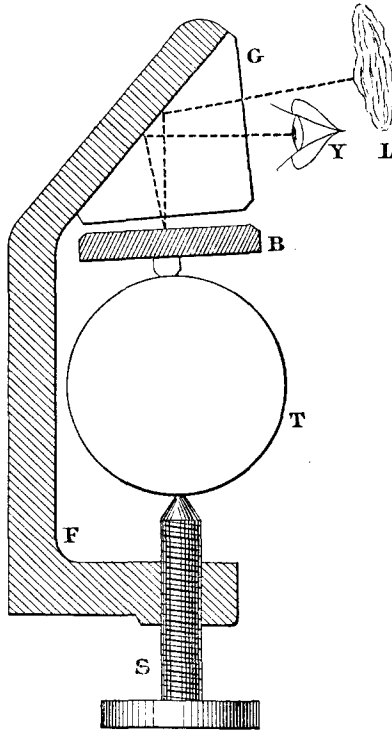

B, and above it a transparent glass prism G. The light from the flame L entered the prism and was reflected from the slanting back to the lower surfaces; here the black and yellow lines were produced and the light re-entered the eye as shown. If the diameter of the test-piece, T, diminished while it was being stretched, the black glass moved away from the transparent one, and the bands moved in the direction from right to left, while if the section expanded they moved in the direction to the right

again. A motion of the bands from black to black represented Mr. Stromeier.  $\frac{1}{86.250}$  inch, so that, by counting them as they moved backwards and forwards and comparing them with the stress applied to the test-piece, the amount of contraction might be measured. Originally the instrument had been designed for measuring local strains in boilers and ships. It was so sensitive that they could be measured on small spans of about  $\frac{1}{2}$  inch or 1 inch; but there was a difficulty in having to carry about a spirit-lamp, and the measurements being so very fine, were easily affected by the spring in the instrument, and he was not able to depend on the absolute value of the readings. He hoped some day to be able to perfect the instrument and to investigate the question of local straining. He had made a few experiments on this subject on boilers and ships, and had found that close to the side of the longitudinal lap-joint, in the shell of a boiler, the strains were four times greater than the calculations would show; that meant that the lap-joint was more elastic than a plate, and that all the strain was thrown on the solid plates. As far as he had observed in experiments on boilers, which had burst under hydraulic pressure, the crack extended through the seam into the solid plate; but he was not sure whether the crack did not first start in the solid plate and not in the seam. He had found by measuring the circumferential strains in a long boiler—a cylindrical tube 4 feet in diameter and 10 or 12 feet long—that the strain increased from the ends towards the centre. It came to about one-seventh of the estimated strain close to the ends where the shell was stiffened by the flat plates; in the centre of the boiler it was six-sevenths. He supposed that the reason why it did not come up to the estimated strains was the number of circumferential seams which gave additional strength to it. The instrument on the table had hardly been tried; it had been designed so that there should be little spring in it, and that its amount could be measured. From a few preliminary measurements which had been made he felt satisfied with the result, and hoped one day to be able to perfect the other as well. He also exhibited two other instruments, both of which had been described at a meeting of the Institution of Naval Architects.<sup>1</sup> One of them was simply an instrument for measuring the elongation of test-pieces. It consisted of two flat plates, between which a very small rolling-pin of fine wire was placed, and to which a pointer was attached. The mode of fixing this gear to the test-piece was very simple. By putting a strain

<sup>1</sup> Transactions of the Institution of Naval Architects. Vol. xxvii. (1886), p. 32.

Mr. Stromeyer, on the test-piece, the plates slid one over the other, causing the rolling-pin to roll and the pointers to revolve. The other instrument was based on the same principle. Two thin plates of iron were clamped to a beam; between the plates was a rolling-pin and a pointer. He had protected it by a glass plate to guard against wind. In order to do away with a long connecting-bar, which would otherwise be necessary to transmit the slight motion from the other end of the beam to the rolling-pin, he had stretched a wire by means of a spring. The only inconvenience of this arrangement was that a slight correction had to be made to the readings. He then showed that by pressing on the centre of the beam the pointer moved through an angle of  $45^\circ$ , proving that the top fibres had slightly contracted. He had experimented with the instrument a good deal on ships, and also on one or two bridges, and the results had been perfectly satisfactory. The rolling-pins were about  $\frac{1}{200}$  inch in diameter; but by using a thicker one, and attaching a pencil to it, he had obtained the diagrams recorded in the Transactions of the Institution of Naval Architects. There would be found (Plate VII.) diagrams of three trains passing over the Hamburg bridge. The instrument was fixed to the lower limb of the big girders of the bridge, and it was shown plainly that as the locomotive came on to the bridge the strain was highest, and when the uniform load was distributed over the bridge it was less than when the tail-end of the train was moving off. That was in accordance with the theoretical views on the subject. When experimenting with the strain-indicator, he had discovered that unless it was fixed to both sides of any beam which was being measured, a good result would not be obtained. Even in the case of a test-piece, when the first pull came on it one pointer sometimes moved back and the other forward. That showed that there was a slight bend in the test-piece, or that the centre of stress did not exactly pass through the centre line. In bridge-work—in fact in all large constructions—he believed that the centre of stress did not always pass through the centre of the plate, and the consequent local buckling caused errors in the readings of the instrument if only one was attached. On that account it was always necessary to fix two instruments, one on each side of the plate, or else to have two on one side of the plate, so that by taking the differences of the two, the mean stress in the centre of the plate could be ascertained. This was a little more complicated than having an instrument on each side, but it was as easy to work it out in that way as in the other. While experimenting on

one bridge in which he thought he could compare the estimated stress with his experiments, he found that they did not agree at all as to the mean stresses; but by taking the centres of effort for three sections, and by drawing a curve through these three centres, he was able to say that the ordinary theories of the distribution of strains were correct, at least as far as that point went.

Mr. EWING MATHESON remarked that the Paper and the discussion that had arisen upon it were useful not only to those who wished to make experiments in laboratories, but also to manufacturers who found it more and more necessary to have testing apparatus in their own factories. Of course it was not possible nor desirable that manufacturers should attempt to emulate the very elaborate kinds of apparatus that were to be found in laboratories; but it was important for them, as their work was going on and as material was being received into the factory, to be able to ascertain something about it, although they might not be able to do it so completely as by the processes adopted in such laboratories as Professor Kennedy's. In steelworks the tests which were so thoroughly made were to a large extent chemical tests, while in laboratories like that at University College they were chiefly mechanical. With steel, perhaps more than with iron, some of the results were very difficult to account for. Sometimes even pieces of steel that had come out of the same converter were different, and it was said that the differences were possibly due to incomplete mixing in the converter, or to some variation in the constituents, not possibly in the carbon or the phosphorus, which were of primary importance, but in the silicon, or the sulphur, or other parts that entered into the composition of steel. He thought that if the two tests could be combined; if every time a piece of steel in the laboratory were broken, or at any rate when the fracture showed something out of the common, or that could not be accounted for, the piece were sent into the chemical laboratory to be tested, and if the results were given in a parallel column on the same sheet with the mechanical tests, certain coincidences would soon be discovered; an excess of strength or elasticity, or too little of it would be associated with certain chemical conditions. The information so obtained would be of great use to engineers and to steel makers. In that respect it appeared to him that many tests were wasted, serving only their immediate purpose of ascertaining quality, but not showing the reason for the results obtained.

Mr. G. R. BODMER did not agree with Professor Smith with Mr. Bodmer.

Mr. Bodmer. regard to the futility for practical purposes of testing pieces to rupture. It should be remembered that there were other questions of importance to practical men besides the mere strength of material. Although the elastic-limit should be the criterion in making calculations, still the total extension and the ultimate breaking-stress gave information as to other qualities of the material which were quite as important for manufacturers as the absolute strength. That was especially the case with materials subject to sudden applications of load or of impact. He thought, therefore, that, in addition to the determination of the elastic-limit, it was always desirable for practical purposes that the total extension and ultimate stress should be determined. With regard to testing materials, he thought that scarcely enough attention was paid to transverse tests. A good deal had been said about tensile tests, but, as far as his experience went, in nine-tenths of the cases in which calculations had to be made with regard to parts of machinery, those parts were subject to bending strains, and he believed that for practical men transverse tests were of equal importance with tensile tests. They had also another advantage, that although they did not give exactly the same class of information, and could not in any way supersede tensile tests, yet it was much more easy to observe the extensions up to the limit of elasticity; because where, in the case of tensile tests, the extension was measured, say, by thousandths of an inch, in the case of a bending test it was measured by thirty seconds. With regard to tests of gas-engines, the Author had remarked that the greatest difficulty was the measurement of the temperature of explosion. Of course that was true with regard to direct measurement; but he thought it was possible to ascertain the temperature indirectly with sufficient accuracy for all practical purposes. To show what he meant, he had prepared two diagrams (Figs. 34 and 35), and he might be permitted to refer to experiments that were made some time ago by Dr. Slaby, the results of which he thought justified the calculation of the temperature of the explosion on the assumption that the expanding gases followed the laws of permanent gases. Of course everything depended on that. If the products of combustion, and the other gases expanding in the gas-engine, followed the well-known law of permanent gases, there was no difficulty in calculating the temperature from the pressure, and he considered that the results obtained by Dr. Slaby afforded pretty good evidence that they did. Dr. Slaby measured directly the quantity of heat absorbed by the cooling water, and he calculated the temperature of the explosion on the assump-

tion that the gases in the gas-engine behaved as permanent gases, Mr. Bodmer, making a small allowance, which was known, for the slight altera-

FIG. 34.

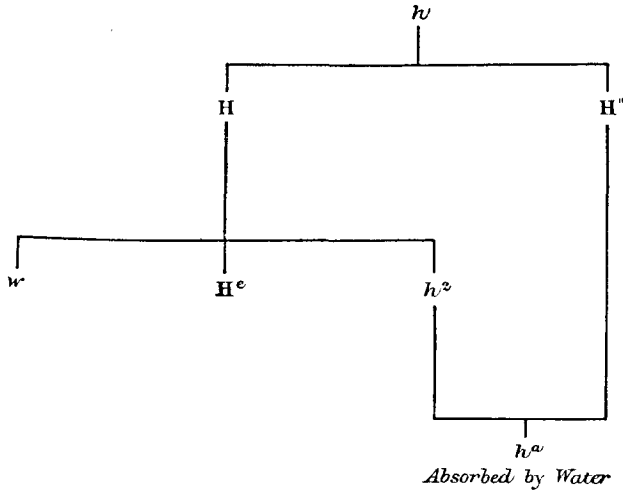
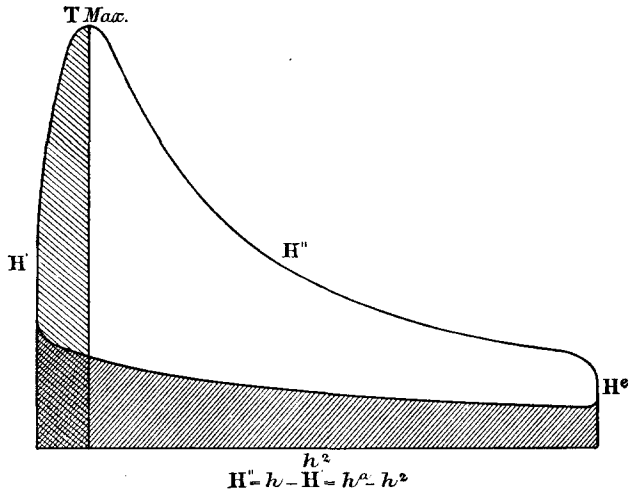

FIG. 35.



tion in the density of the gas after the explosion, compared with its density before the explosion. Fig. 34 showed the way in which the heat was utilized.  $h$  was the total heat of combustion, which

Mr. Bodmer. might be divided into two parts, first, the heat  $H'$  developed during the explosion proper previous to expansion, and, secondly the heat  $H''$  developed by subsequent combustion after the explosion proper had taken place. He had marked all those quantities that were actually observed, or measured directly, in italic letters, and those that were only calculated in capitals. It would be seen that the heat developed during explosion was spent in three ways: one portion was converted into work,  $w$ ; another portion  $H^c$  was expelled with the exhaust; and a third portion  $h^2$ , in the particular case under consideration, was rejected during compression, and absorbed by the cooling water. In the case of that engine the expansion curve was found to be adiabatic, and the compression curve isothermal (Fig. 35). The fact of the curve being adiabatic could only be explained on the assumption, that while heat was being given up to the cooling water, an equal quantity was being communicated by the combustion going on during expansion. Therefore, if the assumptions on which the calculations were based were correct, the heat developed during expansion should be exactly equal to the difference between the total heat of combustion and the heat developed during explosion, and that was a point on which there was direct confirmation in the actual measurements made. It would be seen that the heat  $h^a$  absorbed by the cooling water was equal to the sum of the heat  $H''$  given off during the expansion and the heat  $h^2$  rejected during compression. The heat rejected during compression was a measured quantity, because, as it happened in that particular case, the curve was isothermal; therefore, the heat rejected was exactly equivalent to the work expended in compression, which could be measured directly from the diagram. Hence there were two equations, from which  $H''$  the heat developed by subsequent combustion after the explosion proper could be calculated. In one case there were two quantities,  $h^a$  and  $h^2$ , which were both measured; in the other two quantities,  $h$  and  $H$ , one of which was measured and the other only calculated. That afforded a check on the accuracy of the premises, and as a matter of fact it was found that the agreement was within about 1 per cent. of the total quantity of heat developed. He thought that the study of these results, which were quoted very fully in the lecture by Professor Fleeming Jenkin,<sup>1</sup> in February 1884, would show that there was a sufficiently close agreement between the theoretical and the actual results, to confirm the assumption

---

<sup>1</sup> Lectures on "Heat in its Mechanical Applications." Session 1883-84. "Gas- and Caloric-Engines."

that the gases in the gas-engine behaved as permanent gases with Mr. Bodmer. enough accuracy for all practical purposes, and that the engine formed, so to speak, its own thermometer.

Mr. C. E. COWPER only wished that twenty years ago students Mr. Cowper. had had the chances and opportunities now presented to them. He had been particularly struck with the diagrams showing the curve of stress and strain (Fig. 11). The Author had very successfully made an instrument, by means of which a sample in a testing-machine could draw a curve, and graphically tell its own story. It was very important to give the student a diagram to impress facts upon his memory; he called a diagram a pictorial representation of a fact. A steam-engine was always expected to tell its own character by drawing its own diagram, and the Author had made the samples which he was testing do the same thing. But there was another way of obtaining this, namely, by construction. He had hung upon the wall a diagram, as an illustration of what he meant. This was a diagram of boiler-trials which had been exhibited on the occasion of Mr. E. A. Cowper's lecture on the steam-engine.<sup>1</sup> It was not drawn by the boiler itself, but it was constructed by plotting curves from the table of results obtained from the experiments with the boiler, extending over many weeks. The curve showed the varying proportions of evaporation, heating surface, grate surface, consumption of coal, temperature of escaping gases, and economy. From a study of that diagram it was easy to ascertain what were the limits within which reasonable economy could be obtained. Another reason that he had for the exhibition of the diagram was to suggest to the Author this means of illustrating the experiments with boilers which he had mentioned in his Paper.

Mr. W. ANDERSON thought that the importance of engineering Mr. Anderson. laboratories had not been over-estimated. That such was the case had been shown by the springing up, spontaneously, all over the country, of those admirably equipped laboratories in which students of the present generation had such enormous advantages over those who studied engineering in former years. He drew a broad distinction between the laboratory and the engineering workshop. The engineering workshop, as it was ordinarily conducted was, he thought, of very little use. The time spent in making toy engines, foot lathes, and cabinets for curiosities was time entirely wasted. It was impossible in an engineering work-

<sup>1</sup> Lectures on "Heat in its Mechanical Applications." Session 1883-84. "The Steam-Engine," Plate I. Fig. 1.

Mr. Anderson. shop to make a student into a good mechanic. All that could be done was to give him a certain amount of acquaintance with the materials he had to deal with. The education, therefore, ought to be confined to teaching the student how to work with pieces of metals of considerable size, turning, drilling, planing, forging, and the like, and then doing a certain amount of fitting, to enable him to find out by experience what were the properties of the materials. He should also make the principal joints used in carpentry on the large scale, and learn the principles of pattern-making. But in the laboratory, the student had to determine practically the method of ascertaining the constants which he would be obliged to use when he came to practise his profession. The great advantage of determining the constants for himself was that he would be able to gauge their true value, and know within what limits they could be trusted, which he could not well do without that kind of instruction. It was a misfortune, which was perhaps inseparable from engineering laboratories, that they were necessarily confined to apparatus of a small class, and that they could not be very varied. He thought the discussion had shown that in most laboratories attention had been concentrated upon the testing of specimens of iron and steel, chiefly by tension, and experiments on steam-engines, mostly of a very small size; the attention and energy of the professor had been concentrated on these subjects, and consequently some very remarkable results had been produced. It had occurred to him that, in these days of co-operation, something might be done by federating engineering schools. While each of them would have apparatus for carrying out experiments on a small scale in every department, some would devote themselves to particular lines of experiment. For example: in a great shipping centre, like Liverpool or Glasgow, there would be large apparatus for making experiments with floating bodies, and their resistance in passing through fluids. In a place like Manchester there would be a good steam-engine arranged to work under all kinds of pressures and other varying conditions. In a place like Birmingham attention would be chiefly concentrated upon experiments as to the flow of fluids through pipes. Each school would come to an understanding with other schools, and devote itself to some particular line, and then, by means of federation, the students of one school might have the privilege of being transferred to another for particular classes of experiments. If that were done the value of laboratories would be enormously enhanced, the area of research would be enlarged, experiments would be made upon a greatly more extended scale, and would give the whole movement that practical

stamp which had always characterized the engineering of this Mr. Anderson. country.

Mr. H. S. H. CUNYNGHAME said that the opening pages of the Mr. Cunyng- Paper had had a great deal of interest for him, as he had been hame. employed during the last two years in making inquiries for the Charity Commission in the various modes of education, particularly technical education, which had so much to do with the training of engineers. He had visited most of the great midland towns in England, and he believed he had also visited every technical school in Paris, and the result of his inquiries amounted to this :—There were three classes of boys or young men to be considered. There was the ordinary poor lad who would never be anything but a labourer, a workman, or artisan. Then there was the poor boy, with exceptional abilities, to whom such charities as those which the Charity Commission administered might be of great benefit in enabling him to get a better education ; and then there was the son of the rich man, who could afford to give him the best practical education whatever it might be. As to the first of those classes, it was impossible for the parents to support the boys while they were at the technical schools. The authorities in Paris were positively paying out of the rates nearly £74 per head for those boys in some of the schools, where they were fed and clothed as well as taught. Whether that was wise or not, he would not say, but he doubted it extremely. With regard to the richer boys the question of expense of course did not arise. As to the question of the best mode of making an engineer, he would only say that the word engineer meant one of two things. It might mean a professor who had all his life to study the theoretical part of the subject, and whose help was invaluable ; or it might mean a man who had to deal with the practical affairs of life, and who wanted the moral courage necessary, in case of an accident happening, or a machine going wrong, to show that he could remedy it somehow. An ordinary engineer, who had to deal with practical matters, could not be trained except in the workshop ; but it might be extremely useful to give him a year or two in a school like Professor Kennedy's, in order to teach him that there were such things as science and law ; and that there those delicate experiments really had a direct bearing, if only they were properly understood and allowed for, in practice. While, therefore, deprecating any attempt to make technical schools take the place of the workshop, they might, if used wisely, and to a limited extent, be rendered exceedingly useful ; and every one interested in engineering should hail their introduction with joy. They were thoroughly worthy of support

Mr. Cunyng- if once their function were understood. In France, unfortunately, they had, he thought been pushed a great deal too far. There was the École Polytechnique, and the École Centrale. Most of the young men in Paris had a great idea of going to the École Centrale, where they were kept at theoretical work until they were twenty-five, and where they had given to them "baccalauréat" for engineering, and all sorts of high titles. He had recently spoken to one of the best tool-makers in Paris, Mr. Gerard, who had an interesting school with nearly two hundred apprentices, costing the State nothing, but paying their own way and doing excellent work. Mr. Gerard said:—"I have two sons; I am going to retire, and they must take my place. They want to go to the École Centrale. If they persist in this desire I shall send them off to England, where you people are rather more practical than we are in France. I shall bind them apprentices to some firm of engineers, and they shall have no École Centrale at all. I am a practical man and do not want it." In France the whole business was pushed a great deal too far; but there was possibly a danger of Englishmen underrating such institutions, which, he thought, when properly used in connection with engineering apprenticeship, might be of the greatest value.

Mr. Pearsall. Mr. H. D. PEARSALL thought that, before other experiments were made on the discharge of water through orifices, it was extremely important that preliminary experiments should be carried out as to the form of orifice most useful for gauging. It was clear from the experiments of Mr. Mair, that an orifice in a comparatively thin brass plate was an imperfect gauge; for a slight injury, which could not be detected without taking off the plate for examination, was said to have increased the flow 2 per cent., and an imperfection which could not be detected at all caused a palpable error of 1 per cent. That was very far from the ideal orifice for gauging. He hoped that some of the professors who were provided with instruments, and had time and money for making investigation, would before long contrive something more nearly approaching a perfect gauge. He might be permitted to allude to some of the very extensive experiments of Mr. Hamilton Smith which had been recently published, showing varying and anomalous results with orifices which approached much more nearly to the theoretical "orifice in a thin plate" than those used in any experiments hitherto conducted. Those results, he thought, proved that it was not true that an "orifice in a thin plate" would be an altogether suitable gauge, even if it were possible to make it. It was not, therefore, worth while any longer to aim at

that form, especially as it was impossible to get very near to it in any practical work. Mr. Pearsall.

Professor KENNEDY, in reply, said he desired to thank the members of the Institution for the kind manner in which they had spoken of his Paper. He was also gratified with the general consensus of opinion that some practical instruction of the kind he had endeavoured to describe was of use as a part of engineering training. Mr. Wicksteed had asked a question about the use of a couple of valves for rendering uniform the flow of water from a loaded accumulator. The valves were not put for the special purpose of regulation, but he had found the double regulation very convenient for allowing small quantities of water to pass. With regard to Mr. Wicksteed's contention that it was surely better, by taking, say, a 100-inch specimen, to multiply the length itself, than to multiply by mechanical gearing the readings taken from a short specimen, he thought that the difficulties of arranging an accurate apparatus to read the extensions of a very long bar would probably be more troublesome than the use of a more accurate and smaller apparatus. Then it should be remembered that, although the colleges had been spoken of as rich, they were in reality poor, and the preparation of test-pieces 100 inches long would be a somewhat serious matter. With regard to the statement as to an error of  $\frac{1}{2}$  lb. per ton (p. 16), he had perhaps not made the matter quite clear. He did not mean that  $\frac{1}{2}$  lb. per ton was an error due to inertia or anything of that kind; the  $\frac{1}{2}$  lb. per ton happened to be only an error of leverages in a particular machine, which might be anything. Lastly, Mr. Wicksteed rather differed from him as to one important practical point, namely, whether it was better to have a constant weight for all test-pieces, which weight should be run along the lever for varying distances according to the different size of the test-piece; or whether it was better to have varying weights which would run along the lever approximately the same distance for all test-pieces. It was no doubt a matter on which a great deal could be said on both sides, and it was a matter depending on practical use; but he was inclined to think that in testing a small piece with a large machine of the Wicksteed type, where the weight would only move a very small distance, the total probable error was greater than it would be with a smaller weight running a longer distance. He admitted, of course, that there were chances of error in using ten weights instead of one weight—errors in the weights themselves, but those errors should be put right. Professor Unwin had asked him a question as to the number of men who, in his opinion, could work

Professor Kennedy. in a laboratory of the kind described in the Paper. As a matter of fact he had never employed more than twenty young men at one time in the laboratory, and he did not think that practically he could do so with the apparatus he had described; but with a reasonable increase of smaller apparatus there was plenty of space for at least double that number of men working at the same time. As to the measurement of extensions or strains of one kind or another on both sides of the test-piece, no doubt that was a most important point, and it was one which he had not lost sight of (p. 35). He thought it was unquestionably much better to do it by such an apparatus as Professor Unwin had shown, in which the mean of the extensions on the two sides could be automatically read off from the apparatus, than to do it by any other method. Professor Kennedy's lever apparatus (Fig. 10) did not do that. The method he had employed with it was to use one set of gear on each side of the test-piece, which was perhaps a clumsy and troublesome way. Two men were employed in reading, one on each side, where special accuracy was required, and then the means of the extensions or compressions on the two sides were calculated. Of course it would be much better if the instrument would show it at once, as was done by Professor Unwin's instruments, and by both forms of his own diagramming gear. If, before he had written his Paper, he had seen some of the diagrams obtained from Professor Unwin's semi-automatic elastic diagramming apparatus, he should have spoken more strongly about them. They were about the most beautiful things that had been accomplished in connection with elastic measurements of any kind. With reference to some remarks of Professor Smith, he agreed with Mr. Bodmer that it would be inexpedient to throw away all knowledge of breaking-stress. It was quite certain that other things should be known; but, in saying that he could not see any practical utility whatever in finding breaking-loads, he considered Professor Smith erred in the opposite extreme. The engineer ought to know a good deal about breaking-loads. They ought not to be worshipped as if there were some kind of fetish in connection with 20 tons per square inch, but it should be known that the 20 tons per square inch at least existed. If no importance were to be attached to anything beyond the elastic limit, then iron must be considered equally good or better when pulled across than when pulled along the fibre. He hoped, however, that the whole tendency of his Paper would sufficiently show that in saying this he, at least, did not underrate the importance of elastic experiments. He did not wish it to be thought that he had neglected the point as to original work of students raised by Professor Barr. There had been already printed

in the records of the Institution two Papers,<sup>1</sup> written for the Students' Meetings by his own students on their work in the laboratory, and two or three other Papers were in course of preparation. With reference to Professor James Thomson's brake, alluded to by Professor Barr—which was a most beautiful piece of apparatus—his attention had been drawn to the fact that perhaps the first constant-resistance brake of that kind was the brake described by the late Mr. W. Froude, M. Inst. C.E., in a Paper read before the Institution of Mechanical Engineers in 1858,<sup>2</sup> and ascribed by him to Mr. Imray—a brake in which the arc of contact of the strap was automatically changed. He had never seen the brake at work, but it was stamped with Mr. Froude's approval, and it had every appearance of being a successful instrument. He entirely disagreed with the remarks of Mr. McGregor, whose practical mind, he thought, would, if he really understood the working of the laboratory system, lead him to a different conclusion about it. Mr. Stroudley had alluded to the importance of experiments on the growth of flaws, and the effect of wear and fatigue generally—a point of great practical importance. In some of the German laboratories, experiments on the effects of continually-repeated loads were being made in certain machines, something of the type used by Wöhler in his original experiments on the fatigue of metals. Mr. Stromeyer's apparatus for measuring the cross-contraction of a test-piece was of high scientific interest. He had himself used it lately in sundry experiments, and had found that practically all the original difficulties connected with its use had been removed. It appeared capable of giving results connected with the theory of elasticity which were of considerable importance. Mr. Ewing Matheson had not overrated the importance of combining chemical and mechanical tests. The difficulty was essentially one of time and money; but he hoped that some progress might presently be made in this direction. Microscopical investigations might also be mentioned as being of very great value along with chemical and mechanical tests. In speaking of the difficulties of measuring temperature in gas-engines, he, of course, did not at all overlook the fact that all the temperatures could be calculated. In connection with some gas-engine tests that he had recently made, in which neither the expansion- nor the compression-curves were either adiabatic or isothermal, he still had found that he was able to make the final "heat account" balance very closely. But the

Professor  
Kennedy.

<sup>1</sup> Minutes of Proceedings Inst. C.E. vol. lxxiv. p. 258, and vol. lxxxv. p. 376.

<sup>2</sup> Proceedings. 1858. p. 100.

Professor Kennedy. final corroboration due to direct measurement was very much wanted. He had found, in his own practice, that it was a great convenience to have an engine-trial, or anything of that kind, actually diagrammed while it was going on. It enabled everything that was happening during the whole of the trial to be seen thoroughly. Mr. Anderson had suggested a magnificent project for the Jubilee—a confederation of engineering laboratories throughout the country! He should be very glad if something of the kind could be practically carried out. In speaking so much of tension-tests in his Paper, he had perhaps laid more stress upon them than they received in his actual work. He had mentioned (p. 5) that tests were practically carried on in all kinds of stress. With reference to one word used by Mr. Cunynghame, and also by the President, he had a little fault to find. A distinction had been drawn between professorial and practical men; against this he desired to protest. He hoped it was not necessary to assume that because a man who was an engineer became also a professor, he then and there ceased to be practical. He had hoped that Professor Perry would have said something about his laboratory at Finsbury, which differed in some important respects from that described in the Paper. Professor Perry had to deal with a somewhat different class and age of student, and to deal with him in a somewhat different way. He did so, as far as laboratory work was concerned, by experiments which began by being perhaps pure mechanics, and ended by being nearly altogether engineering, and he should have been glad to hear Professor Perry's own description of his mode of work. In reference to Professor Smith's remarks about calibration (p. 100), he had to say that by using a reversible bell-crank lever with nearly equal arms, any errors in the lengths of the arms could be eliminated without measuring them. He had once or twice pointed out before the Institution that a good deal of practical value could be got from a knowledge of the work done on a piece of material while being tested. Of course the value of this work in inch-tons could be got from any form of automatic diagram, but automatic diagramming was very often practically out of reach. He had pointed out<sup>1</sup> that if the elastic limit, the

<sup>1</sup> Minutes of Proceedings Inst. C.E. vol. lxi. p. 30; and vol. lxxvi. p. 115.

The formula referred to is  $w x \left( \frac{r+2}{3} \right)$ , where  $w$  is the maximum stress in tons per square inch,  $x$  the proportional extension, and  $r$  the ratio of limit to break. Used in this form the result is inch-tons per cubic inch of material—a convenient standard.

breaking-load, and the final extension were known, by combining those together in a particular way a very close approximation to the work done in breaking the piece could be arrived at. He had tested the formula frequently, and found that it gave a value within 2 or 3 per cent. of the diagram, which was sufficiently near for many practical purposes. He was now in the habit of putting that value upon all test reports which he sent out, and he thought that the comparison of such values after a time would be extremely interesting. Occasionally very ductile materials, which were also very strong, gave a work up to 8 or 9 inch-tons per cubic inch of material. More commonly good material gave 4 to 5½ inch-tons per cubic inch, and poorer material 2 or 3 inch-tons per cubic inch. The measurement of work in that fashion, if it could be easily and practically done, gave what the Germans called a value-number; this combined very usefully most of the points which engineers looked at practically in valuing materials.

Mr. Woods, President, said he must apologize to the Author and the other professors who had favoured the Meeting with their observations. By a slip of the tongue he had apparently distinguished between professors and practical men. No one was more willing than himself to acknowledge that the professors, who had been inaugurating valuable engineering laboratories, were in every sense practical men. He had simply suggested that the learned professors having stated their opinions, the practical men—by which he merely meant those who were engaged in the actual construction of machinery, bridge-work, and so on—should also have an opportunity of expressing their views. He thought the discussion ought not to terminate without the members recognizing the great value of the laboratories which had been instituted. Those who were engaged in engineering works were fully aware of the service which those laboratories rendered to engineers in their practice, and he was sure that they could not recognize too highly the assistance given to them from time to time by the gentlemen conducting those laboratories, to whom they were constantly obliged to appeal for information as to the strength of the materials which they had to employ in the construction of works.

### Correspondence.

Mr. B. BAKER expressed his entire concurrence in the Author's arguments and conclusions. He was one of the first to whom the Author communicated his desire to establish an engineering labo-