

# Monopoly in the container shipping market: an econometric approach

Takuma Matsuda

*Faculty of Commerce, Takushoku University, Tokyo, Japan*

Enna Hirata

*Center for Mathematical and Data Sciences, Kobe University, Kobe, Japan, and*

Tomoya Kawasaki

*Department of Systems Innovation, The University of Tokyo, Tokyo, Japan*

## Abstract

**Purpose** – Since the 2010s, market conditions for container shipping companies have been deteriorating owing to decreasing container cargo trade and increasing supply capacity. This study aims to contribute to the empirical literature on the container shipping industry market structure. Specifically, this study aims to investigate the extent of market competition.

**Design/methodology/approach** – This study analyzes the market structure and evaluates the market power of shipping companies through a non-structural test.

**Findings** – The  $H$ -statistic for the entire period of 2004–2018 was 0.37, which is significantly different from zero. This indicates the absence of monopoly pricing throughout the entire period. For the time-phased estimates, the  $H$ -statistic between 2004 and 2008 is 0.15, which is not significantly different from zero. On the other hand, the  $H$ -statistic from 2009 to 2018 was 0.40, which differs significantly from zero.

**Originality/value** – As the Far East Freight Conference had released tariffs and charge rates by item for container shipping routes, monopolistic pricing is said to have appeared until the European Union abolished the European Economic Community (No. 4056/86) in 2008, before the economic crisis. However, this study indicates that pricing in the container shipping industry has been distinctly non-monopolistic; further, competition seems to have intensified since 2008. Industry competitiveness is of interest not only to academics but also to practitioners, including policymakers, especially when considering competition policies.

**Keywords** Container shipping market, Monopoly, Oligopoly,  $H$ -statistic, Non-structural test, Competition

**Paper type** Research paper

## 1. Introduction

In the 1990s, the transition to a market economy in former socialist countries along with the economic development of China, the newly industrialized economies (NIES), and the Association of Southeast Asian Nations (ASEAN), jointly led to an increase in the volume of transportation from Asia. However, the intense demands from cargo owners for a global transport system with more efficient marine logistics and improved transport services were challenging for a single company to fulfill.

Moreover, the introduction of over-Panamax ships in 1988 accelerated the increase in vessel size, and fleet expansion outpaced the growth in cargo movement. This led to a supply excess after the late 1990s (Figure 2). In 1990, the Maersk Line and Sea-Land Service allied to service key routes in North America, Europe and the Atlantic (Hirata, 2018). In what is believed to be the first of its kind, in 1994, Mitsui O.S.K. Lines (MOL) allied with American President Lines (APL), Nedlloyd, and Orient Overseas Container Line (OOCL) to form The Global Alliance (TGA). In 1995, Nippon Yusen Kaisha (NYK) formed the Grand Alliance (GA) with Hapag-Lloyd, Neptune Orient Lines (NOL) and P&O Containers. In 1996, Kawasaki



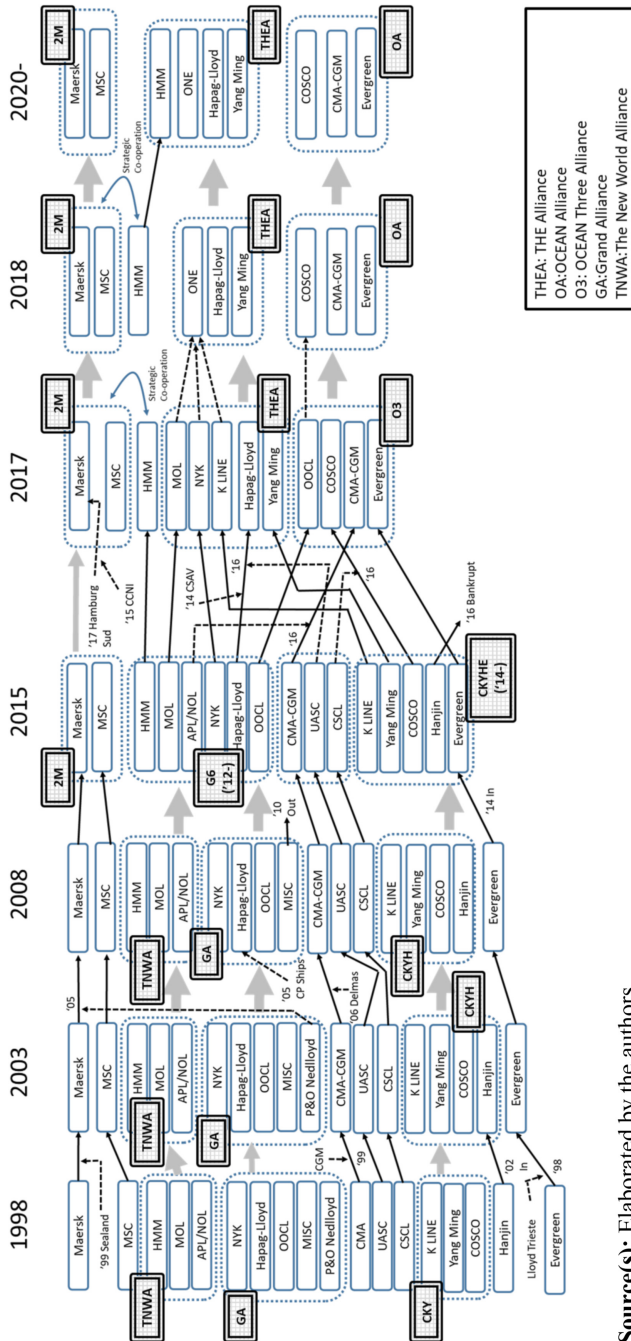

Source(s): Elaborated by the authors

Figure 1. Major shipping companies and alliances in the world

**Figure 2.**  
World container vessels' capacity (in TEU) and world container seaborne trade volume (in Tons)  
(Unit: Index(1986 = 100))

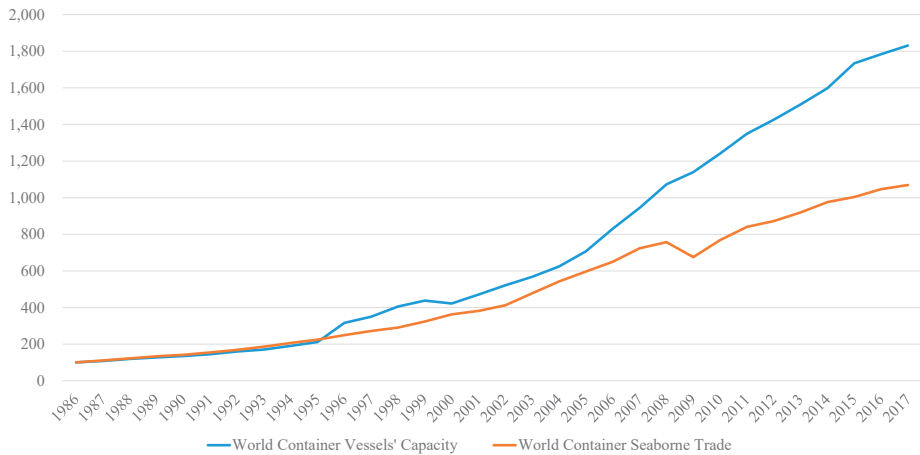

**Source(s):** NipponYusen Kaisha

Kisen Kaisha (K-LINE), China Ocean Shipping Group (COSCO) and Yang Ming Line (Yang Ming) formed the CKY Alliance (Figure 1).

By the mid-2000s, container cargo movements increased significantly owing to China's accession to the World Trade Organization, steady United States (US) economic conditions, housing bubbles and strong European economic growth. Thus, market conditions remained stable despite the increase in the number of vessels with a capacity of 5,000 twenty-foot equivalent unit (TEU) or higher as well as continued growth in container capacity. The amount of containerized cargo has been increasing steadily, and competition in the container transport industry was placid compared to the 1990s. According to Containerization International's container freight index, the average coefficient of variation in container freight rates of trunk lines from 1993 to 2000 is higher (0.172) than that from 2001 to 2008 (0.136). However, a notable development was the addition of Hanjin Shipping (Hanjin) to CKY in 2001, which became CKYH. In addition, most of the mergers and acquisitions in this period were aimed at expanding the scale of operations, including Maersk's acquisition of P&O Nedlloyd in 2005, Hapag-Lloyd's acquisition of CP Ships in 2005 and CMA-CGM's acquisition of Delmas in 2006 (Figure 1).

This trend changed in 2007 when the sub-prime mortgage crisis was uncovered by financial institutions and the housing bubble burst in the USA. This reduced the pace of growth in transport volumes, and the collapse of Lehman Brothers the following year caused the volumes to decline. Since 2009, transport volumes have had annual reductions.

However, the shipbuilding boom, which had started before the financial crisis, significantly increased shipping capacity. To sustain the decreased transport volume, vessel sizes were increased to reduce the unit operation cost (average cost); consequently, vessels with capacities exceeding 10,000 TEU were introduced. The maximum current vessel size exceeds 23,000 TEU. This has further encouraged capacity expansion. From 2005 to 2020, the world's container vessel capacity tripled from 7.28 million TEUs to 22.97 million TEUs. Of this increase, 75.8% was due to the rise in capacity of over-8000TEU vessels (Clarksons research, 2021).

The lack of trade growth to match economic growth (UNCTAD, 2015; Ha and Seo, 2017) further upsets the balance between supply and demand each year. Compared to the volumes transported in 1986, the tonnage volumes transported in 2007 and 2016 were 7.23 and 10.47

times more, respectively. However, compared to the capacities in 1986, the container vessel TEU capacities in 2007 and 2016 were 9.44 and 17.84 times higher, respectively (Figure 2). Therefore, the capacity increase exceeded the cargo volume increase, which caused the balance between supply and demand to deteriorate continuously each year (Figure 2).

Despite these challenges, shipping companies have increased in size and have achieved economies of scale (Ha and Seo, 2017). Consequently, container shipping companies have implemented a wave of new mergers and reshuffling cooperation agreements (alliances) (Crotti et al., 2020). Reforming alliances and mergers between carriers, such as the 2 M, Ocean Alliance (OA) and The Alliance (THEA), began in April 2015.

The mergers and alliances (M&As) move mainly began after 2014, when announcements regarding the Hapag-Lloyd's acquisition of CSAV (Chile) and Hamburg Sud's acquisition of CCNI (Chile) were made. In 2015, the CMA CGM's acquisition of ODPR (Oldenburg-Portugiesische Dampfschiffs-Rhederei in German), the German shipping company, CMA-CGM's acquisitions of NOL and COSCO Container Lines, and of CSCL were announced. In 2016, in addition to the acquisition of UASC by Hapag-Lloyd and the Hamburg Sud by Maersk, the consolidation of NYK, MOL and K LINE container shipping divisions was announced, and they organized the company in Singapore in 2017.

As a result, container company market concentration has increased worldwide. In 1985, the top five container ship operators accounted for 26.8% of the world's tonnage, and the top 10, 41.3%. However, it increased to 64.5% for the top five companies and 83.6% for the top ten companies in 2018 (Figure 3). Therefore, in the container shipping industry, currently a small number of companies transport a large number of containers due to consolidation.

This study contributes to the empirical literature on the market structure in the container shipping industry by investigating the extent of market competition considering recent consolidation. The container shipping industry tends to have price competition because of the difficulty in differentiating container shipping services, as container transport services, especially on the board, are inherently homogeneous (Merk et al., 2018; Hirata, 2018). Additionally, this study aims to clarify whether firms have monopolistic markets; this does not simply refer to pure monopoly structures and explicit collusion, such as price cartels, which may be difficult to realize initially. Tacit collusion and price leadership were also included in this category. Industry competitiveness is of interest not only to academics but also to practitioners, including policymakers, especially when considering competition policies.

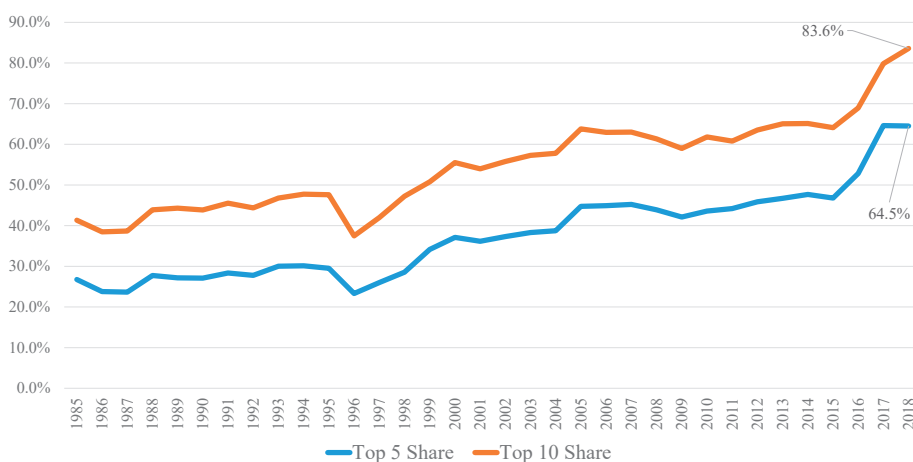

**Figure 3.**  
Share of major  
container shipping  
companies in vessels'  
capacity

Source(s): Nippon Yusen Kaisha

The remainder of this paper is organized as follows: In [Section 2](#), the literature review and research question are presented. [Section 3](#) describes the data and methodology, and [Section 4](#) discusses the results of the empirical analysis; the implications of the container shipping industry market structure on competition policy are discussed. [Section 5](#) wraps up the study.

## 2. Literature review and research question

### 2.1 Literature review

Previous studies examined alliances in the container shipping industry. [Fenn et al. \(2008\)](#) investigated the relationship between market share and cost-efficiency. [Slack et al. \(2002\)](#) examined service transformation, fleet size and composition and port of call coordination to form strategic alliances. They suggested the deployment of the largest ships on the alliance routes and an increase in service frequency at each port of call as the main changes caused by the alliances. Further, [Slack et al. \(2002\)](#) noted that the proliferation of alliances led to greater standardization.

[Fusillo \(2006\)](#) also examined the impact of the Ocean Shipping Reform Act of 1998 on the profitability, efficiency and industry structure of container shipping companies in the USA since its enactment. He suggested that converting to a large shipping entity through an alliance could increase efficiency on a scale that is inaccessible to small- and medium-sized shipping companies. This is because large shipping alliances can use larger vessels and reduce port costs per handling volume with their bargaining power. [Merk et al. \(2018\)](#) also assessed the impact of global alliances on container transport and reported that carriers can acquire and operate mega-ships through alliances and reduce unit costs.

However, [Merk et al. \(2018\)](#) and [Midoro and Pitto \(2000\)](#) pointed out that alliances are inherently unstable. The latter pointed out that the main reasons for instability are increased organizational complexity and intra-alliance competition. [Song and Panayides \(2002\)](#) found that shipping alliances tend to be unstable when applying the cooperative game theory model. Further, [Sheppard and Seidman \(2001\)](#) reported that shipping companies' ultimate goal is to remain in control and grow their business. The container shipping companies in the alliance want to enjoy their benefits without having to make a deep commitment, such as a partnership or merger. This motivation leads to alliance instability, which is considered a form of cooperation. Addressing this instability, [Panayides and Wiedmer \(2011\)](#) stated that managing alliances requires considerable effort. By analyzing the strategic agreements of alliances in the 2000s, they found a consistent adjustment of services for strategic or managerial reasons.

Further, [Merk et al. \(2018\)](#) pointed out that alliances may cause competition in concentrated markets. Although in alliances, there are shipping companies that aggregate the participating firms and increase their cost competitiveness and bargaining power, it is not entirely clear if consolidation into larger alliances leads to competition in the container shipping market.

Methods for evaluating industry competitiveness in industrial economic structures have been suggested. For example, [Brander and Zhang \(1993\)](#) and [Oum et al. \(1993\)](#) used a measure of industry competitiveness, known as conjectural valuation, to analyze the airline industry.

Additionally, the  $H$ -statistic, suggested by [Panzar and Rosse \(1987\)](#), is a well-known method for determining the degree of competition. In this method, the percentage change in revenue is measured when all factor prices increase by 1%. [Panzar and Rosse \(1987\)](#) suggested that  $H = 1$  indicates perfect competition;  $0 < H < 1$  indicates monopolistic competition; and  $H \leq 0$  indicates a monopolistic market, including collusion. The  $H$ -statistic is below zero if the market is monopolistic, including the cartel-state. When the market is monopolistic, the increase in the price of production factors reduces the optimal production volume and thereby revenues. The  $H$ -statistic is often adopted because of its advantage in that it is not necessary to specify a demand or cost function.

This method is often adopted when measuring competitiveness in the banking industry; the banking and insurance sectors have been extensively analyzed in the literature ([Nathan](#)

and Neave, 1989; Shaffer, 1993; Murat *et al.*, 2002; Murjan and Ruza, 2002; Claessens and Laeven, 2004; Yuan, 2006).

Furthermore, some studies based on the transportation sector have adopted the *H*-statistic to evaluate market competitiveness (Savage, 1995; Fischer and Kamerschen, 2003). This statistic was adopted by Endo (2005) to analyze the Japanese ocean-going shipping industry, and by Sys *et al.* (2011) and Hirata (2018) to analyze the container shipping industry. They concluded that the container shipping industry was in monopolistic competition, even for different periods. However, their market structure interpretation was based on the “traditional” view and may have been erroneous. As will be discussed later, it is difficult to determine the degree of competition in a market using only the *H*-statistic. Furthermore, previous studies have a limitation in assessing only the container market conditions on a route basis. Deployment routes for the international container shipping industry may vary, and container shipping companies in large alliances worldwide do not compete for a single route. Therefore, company-based analysis is more appropriate for this industry.

The *H*-statistic was initially proposed to discriminate not only monopoly but also monopolistic competition and perfect competition. Many previous studies in the financial sector and others have been conducted using the same concept. However, Matsumura (2005) indicated that the *H*-statistic should be adopted to determine only whether a market structure is monopolistic, because the size of the *H*-statistic may not reflect the state of competition in other cases. Following this indication, this study uses the *H*-statistic to determine whether a market is monopolistic. Therefore, we apply this method while avoiding the drawbacks of previous studies.

## 2.2 Research question

Based on the current situation characterized by increasing numbers of horizontal merger deals, this study addresses the research question: how can the increasing number of horizontal merger deals be explained from an economic theory perspective? To address this question, it is necessary to examine the type of market in this industry. Therefore, the objective here is to examine whether monopolistic pricing is applied to the container shipping industry market. We address significant questions from a practical perspective, rather than simply providing an academic analysis of the container shipping industry's structure since these questions serve as guidelines for creating competition policies and firm management.

Unlike previous studies that take a route-based approach, this study assesses container shipping market competitive conditions from a company perspective, which fills an important research gap.

## 3. Methodology

### 3.1 *H*-statistic

This section describes how the monopolistic nature of a market is tested using the Panzar–Rosse *H*-statistic. This statistic is calculated as the sum of the factor-price elasticities of a firm's revenue. Assuming  $R(y, p_1, \dots, p_n, w)$  denotes a firm's revenue, it is a function of production quantity, sales, production factors, and an exogenous variable,  $w$ . Production quantity is indicated by  $y$ . Further,  $p_i$  is defined using the price of the production factor  $i$ , and  $\theta$  is the third exogenous variable representing unidentified factors. Finally, the cost functions  $C(y, p_1, \dots, p_n, \theta)$  indicate the total cost of the firm. Therefore, the profit function  $\pi$  is defined as follows:

$$\pi(y, p_1, \dots, p_n, w, \theta) = R - C = R(y, p_1, \dots, p_n, w) - C(y, p_1, \dots, p_n, \theta) \quad (1)$$

If it is assumed that  $y^* = \operatorname{argmax} \pi(y, p_1, \dots, p_n, w, \theta)$ , then the revenue function  $R^*(y^*, p_1, \dots, p_n, w)$  is on a production level that satisfies the first-order profit maximization condition and is a function of the production factors and exogenous variable  $w$ . Finally, the  $H$ -statistic is defined as the sum of the production factor-price elasticities of the revenue function  $\sum_{i=1}^n \frac{\partial R^*}{\partial p_i} \frac{p_i}{R^*}$ .

If the  $H$ -statistic is equal to or less than 0, the market is monopolistic, as both marginal cost and revenue are positive in a monopolistic situation. Under this condition, when marginal costs increase with increasing factor prices, the optimal output for monopolists decreases. Accordingly, both production and income decrease.

Since no data on factor prices were available, [equation \(2\)](#) was estimated to calculate the  $H$ -statistic. We used a fixed-effect model to estimate [equation \(2\)](#) and obtain the coefficients for production factor-price variables. Because the log-linear form was used in the formulation, the price coefficients can be regarded as price elasticities. The  $H$ -statistic is defined by the sum of these factor price elasticities for a firm's revenue; thus, it is obtained as  $H = b_1 + b_2 + b_3$  and indicates whether the container shipping market is monopolistic, based on whether the  $H$ -statistic is significantly greater than zero.

$$\operatorname{Log} RE_{it} = a + b_1 \cdot \log p_{1t} + b_2 \cdot \log p_{2t} + b_3 \cdot \log p_{3t} + \varphi W_{it\#} \quad (2)$$

where  $RE_{it}$  indicates the total revenue of container shipping company  $i$  in year  $t$ . Also,  $W_{it}$  is the vector of other control variables for a container shipping company  $i$  in year  $t$ , then  $a$ ,  $b_i$ , and  $\varphi$  are coefficients to be estimated.

In economics, capital, labor and other factors are the main explanatory variables for the production function. We also need the rental price of capital, the wages of employees, and other operational prices as production factor prices. However, the capital price, wage rate prices and unit price pertaining to container shipping operations cannot be obtained. Therefore, the following proxy variables are used: DA/TA is the proxy variable for the capital price, SGA/TA is used as the wage rate, and OPEX/TEUcap is the substitute for container shipping operation price. DA/TA indicates depreciation and amortization expenditure plus interest payment (DA) divided by total assets (TA); SGA/TA refers to selling, general, and administrative expenses (SGA) divided by TA; and OPEX/TEUcap indicates total operational expenditure (OPEX) divided by TEU-based deployed capacity (TEUcap). Based on the accounting system, depreciation expenses for ships are not included in the DA, and crew salaries are not included in the SGA. However, all of these values were included in the OPEX.

In the analysis of  $H$ -statistics, it is desirable to use individual company data, but [Hirata \(2018\)](#) does not conduct the analysis using the data of financial statements; [Endo \(2005\)](#) and [Sys et al. \(2011\)](#) calculate the proxy variables of production factor prices based on financial statement data. However, [Endo \(2005\)](#) has a problem in that the cost items include figures for sectors other than the container transport sector. [Sys et al. \(2011\)](#) used staff expenses in financial statements to calculate wages. Seafarers' salaries may fall under operating costs in financial statements (e.g. Japan), so the variable may not have responded to seafarers' wages. In addition, the use of detailed data, such as the number of employees, has become a significant drawback in reducing the number of observations. Furthermore, when shipping companies charter ships, the number of seafarers is not reflected in the number of employees. Therefore, there is a problem in capturing employee numbers. In our study, to avoid such problems, we use all the figures for the container sector and include the costs related to seafarers in operating costs.

### 3.2 Data

The dataset for this study comprised 15 container-shipping firms (Maersk, CMA-CGM, Hapag-Lloyd, COSCO, Evergreen, Yang Ming, Hyundai Merchant Marine (HMM), OOCL, NYK, MOL, K-LINE, China Shipping Container Lines (CSCL), NOL, Hanjin Shipping, and ZIM integrated shipping services (ZIM). The observation period was from 2004 to 2018. However, this panel was unbalanced because three companies were merged (OOCL, CSCL and NOL), Hanjin went bankrupt, NYK, MOL and K-LINE began joint ventures and stopped containership operations. Further, data for two unlisted firms (Zim and CMA-CGM) could not be obtained for the full observation years. In total, the dataset comprised 194 observations, and the performance variables were derived from the Standard and Poor's Capital IQ Database. TA, DA, SGA, OPEX and RE were converted into US dollars using year-end exchange rates obtained from the Federal Reserve Board website and deflated to their real value using the consumer price index of the United States on the International Monetary Fund's World Economic Outlook Database in April 2019.

Table 1 shows a summary of the statistics for all non-time-related variables. As shown, the averages for all variables exceeded their medians, indicating an upward bias. Particularly for DA/TA and TA, the average values were boosted by high-value firms and near the 75% quantile; for TA, the high average value and standard deviation indicate variance in firms' scale. On the other hand, the relatively large value of the DA/TA average seems to reflect the differences in the debt structure of companies. This value suggests that some companies have large debts and are in difficult financial situations.

## 4. Empirical results and discussion

Table 2 shows the estimated results for the reduced-form revenue function. As shown, a distinct change between the period before 2008 and after 2009 was noted, as considerable changes took place in this period. Therefore, the results of estimates from 2004 to 2008 and from 2009 to 2018, as well as those across the entire sample period, from 2004 to 2018, are presented.

The reason behind the imbalance between these two periods was that 2008 was a significant year: the EU repealed the exemption system for liner conferences (Rule 4056/86). This was a considerable change in the container shipping industry and market; cooperative behavior was completely banned in the trunk lines. Additionally, this repeal was a shock to shipping

	DA/TA (mil. USD)	SGA/TA (mil. USD)	OPEX/TEUCap (mil. USD)	TA (mil. USD)	RE (mil. USD)	TEUCap (TEU)
Average	0.028	0.056	0.009	6288.24	3497.67	6,30,151
Standard deviation	0.002	0.031	0.007	6972.21	2558.05	6,15,447
Skewness	5.505	0.648	0.583	5.333	3.843	7.693
Minimum	0.002	0.002	0	232.5	98.21	1,24,081
25% Quantile	0.008	0.035	0.004	2122.05	1963.01	3,14,407
Median	0.012	0.051	0.007	3548.31	2669.48	4,15,140
75% Quantile	0.043	0.077	0.012	7778.43	3777.25	6,05,116
Maximum	0.2	0.169	0.029	33613.03	13332.36	39,86,085
Observations	193	180	193	193	194	194

**Note(s):** TA (Total Asset) and RE (Total Revenue) are exchanged and deflated to real values

**Source(s):** Standard and Poor's Capital IQ Database, Nippon Yusen Kaisha Investor Relation Website, Federal Reserve Board Website and International Monetary Fund's World Economic Outlook Database, April 2019

**Table 1.**  
Summary statistics

Variable	Name of coefficient	Entire period 2004–2018		Period 2004–2008		Period 2009–2018	
		Coefficient value	Standard error	Coefficient value	Standard error	Coefficient value	Standard error
$\log p_1$	$b_1$	-0.003	-0.033	0.085	-0.037**	-0.102	-0.034**
$\log p_2$	$b_2$	0.325	-0.067***	0.025	-0.068	0.743	-0.085***
$\log p_3$	$b_3$	0.046	-0.064	0.035	-0.085	-0.238	-0.09***
Total asset	$\varphi$	0.614	-0.071***	0.316	-0.099***	0.858	-0.04***
Time dummies	$\varphi$	YES		YES		YES	
Constant	$\alpha$	4.033	-0.672***	5.802	-0.998**	1.32	-3.669
$R$ -Squared (within)		0.6059		0.8381		0.6345	
$H$ Statistics		0.3682		0.1461		0.4026	
$F$ Value to test $H$ statistic		19.49***		1.87		17.18***	
No. of companies		15		12		14	
Observations		180		59		121	

**Table 2.** Estimation results from the non-structural revenue function

**Note(s):** Standard errors of coefficients in parentheses. \*\*\*, \*\* and \* indicate that the coefficient is significantly different from zero with a level of 1%, 5% and 10%, respectively

companies since the US enacted the Shipping Act in 1984. For shipping companies, risk detection by cartels was highly strengthened; however, these actions were only implemented outside Europe. This study evaluates whether the market situation changed before and after the EU repealed Rule 4056/86.

First, the estimated income function suggests that, for  $\log p_1$ , the effect of capital prices is reversed: before 2008, an increase in capital price had a significant positive effect on income; however, after 2009, the coefficients' signs were reversed and the capital price had a negative and significant effect on income.

Second, for the  $\log p_2$ , an increase in the unit cost of sales and management services led to increased revenue.

Third, the  $\log p_3$  results suggest that the increase in operational costs, for example, seafarer and fuel costs, did not lead to an increase in revenues.

Finally, we used TA as part of  $W_{it}$ , the control variables. TA controls the scales of container shipping firms because the difference in scale is considerably large, despite the small sample size of major shipping companies. We also use time dummies to avoid the effects of extraordinary events, such as the financial crisis between 2008 and 2009. Using these variables, we were able to derive estimating equations with high explanatory power; the coefficients of determination were relatively high ranging from 0.61 to 0.84. This confirms the adequacy of the estimation.

The  $H$ -statistic for the entire period between 2004 and 2018 was 0.37, which is significantly different from zero. This suggests that there is no monopoly pricing across the entire period. For the time-phased estimates, the  $H$ -statistic from 2004 to 2008 was 0.15, which was not significantly different from zero. On the other hand, the  $H$ -statistic from 2009 to 2018 was 0.40, which differed significantly from zero.

Therefore, from our analysis, it cannot be deduced that monopolistic pricing had emerged before the EU abolished the EEC (No. 4056/86) in 2008, before the economic crisis. Moreover, pricing has distinctly become non-monopolistic since then. Namely, it cannot be said that the container shipping market was monopolistic even when the shipping conference was exempted from the EU's competition law; of course, the monopoly did not exist after abolishing the exemption. The result that the container shipping market is not

monopolistic is also consistent with previous studies (Endo, 2005; Sys *et al.*, 2011; Hirata, 2018).

As discussed above, the *H*-statistic should only be used to determine whether a company is monopolistic. Therefore, it is not desirable to use changes in the *H*-statistic to express changes in the degree of market competition. However, other evidence shows that competition intensified after 2008. The China Containerized Freight Index, a freight rate index for containerized cargo from Chinese ports, shows that the coefficient of variation from 2004 to 2008, the period analyzed in this study, was 0.06, while from October 2008–2018, it has increased to 0.17. In addition, the means of the indexes are 1,097 for the former and 954 for the latter. They were also significantly different at the 1% level. The increased volatility and lower freight rates in the container transport market support the view that competition has become fiercer than in the past. The view that competition has intensified in recent years in the container shipping market is also consistent with Hirata (2018).

Despite shipping company consolidation, as shown in Figure 1, container shipping market characteristics are thought to be why competition seems to intensify in the form of more volatile freight rates and lower average freight rates. As Hirata (2017) and Hirata (2018) stated, the container ship market may be contestable, meaning that other shipping companies (potential rivals) may enter the market if either the monopoly or oligopolistic companies are profitable. This may subsequently cause new entrants to offer slightly lower prices to customers of existing shipping companies. Thus, existing companies are forced to lower transport costs to deter rivals from entry. As a result, even with only a small number of companies in the contestable market, the freight rate cannot be increased, and profit cannot be obtained. Hirata (2017) pointed out that the market share of container shipping companies does not affect transport costs, even with only a few companies. The findings from the monopoly test in this study support this view. Some companies have tried various measures to differentiate their container shipping services intrinsically and cooperate with logistics services. However, the scope of future studies remains limited.

This study analyzes the market structure, and as such, the results have implications for competition policy in every country. At present, the EU and major countries, including the USA, Japan and China, are taking measures to address ocean shipping, where freight competition is increasing. In the past, a shipping conference dominated and unified freight rates; however, deregulation was promoted, and each country could select the appropriate form based on their legal system, which allowed individual and free price negotiations between shipping companies and shippers (Japan Maritime Center, 2016). After the EU repealed the exemption system for liner conferences (Rule 4056/86), no country subsequently abolished its competition exemption system or applied the new competition law to the ocean shipping field (Japan Maritime Center, 2016).

At present, no single carrier can operate across the entire loop of core routes; hence, an alliance has been formed to cover these routes (Hirata, 2017). Currently, moves in the EU are underway to suspend or reduce the application of alliance or consortium exemptions (Commission Regulation 906/2009) in 2020.

However, undertaking regular services through alliances is in line with shippers' demands, and a survey conducted by the Japan Maritime Center involving shippers in Japan did not suggest eliminating the exemption for alliances (Japan Maritime Center, 2016). Terminating the alliance, despite container shipping companies having made efforts toward profitability (Kawasaki and Matsuda, 2015; Matsuda *et al.*, 2020), would increase market difficulties. The global transportation system will probably survive through mergers, and transportation costs are expected to increase in the coming years owing to continuing diseconomies of scale. Owing to the contestable shipping market and the low freight rate in relation to the cost, it is highly likely that an increase in transportation cost will in turn cause a

large increase in the shipper's fare. Therefore, there is no reason to abolish the exemption of alliances actively from competition laws, even from the shipper's perspective.

While competition authorities do not require exemptions, in case they establish guidelines (Merk *et al.*, 2018), they may exhibit arbitrariness. It is important that (1) the criteria set forth in the guidelines should be clear and specific (the policy for dealing with as many options as possible should be close to a clear complete contract). Additionally, (2) they should commit to not change the content of the published guidelines, unless the establishment of guidelines is likely to severely limit shipping company activities due to policy instability. As for (1), the clear and specific interpretation of the guideline is left to the discretion of the competition authority, and (2) there is no assurance that the guideline will be changed at a convenient time (it is a source of dynamic inconsistency).

If Commission Regulation 906/2009 is abolished or the extension is suspended, mergers may proceed. However, analysis of other industries also indicates that the consolidation of about three companies is not considered a problem from the perspective of innovation and social welfare (Igami and Uetake, 2020). Therefore, excessive interference in mergers should be avoided.

## 5. Conclusion

Container company market concentration has increased worldwide over the past decades. In the container shipping industry, a small number of companies are responsible for transporting a large number of containers. The formation of shipping alliances and M&As can be considered as the primary reason for the disproportionate market share. This has led to obvious concerns about monopolistic behavior in the market. However, companies in an alliance are not aligned in the direction or purpose of exhibiting monopolistic behavior. Therefore, the container shipping industry's competitive conditions necessitate careful decisions from competition regulatory authorities before any judgment is passed.

This study evaluated the extent of market competition in the container shipping industry by analyzing the market structure and market power through a non-structural test with *H*-statistics. The *H*-statistic for the entire period of 2004–2018 was 0.37, which indicates the absence of monopoly pricing in this period. For the time-phased estimates, the *H*-statistic between 2004 and 2008 is 0.15, which is not significantly different from 0. In contrast, the *H*-statistic from 2009 to 2018 is 0.40, which differs significantly from 0. Even though we cannot draw a conclusion directly from *H*-statistics, other evidence suggests that market competition intensified after 2008.

This study's contributions are two-fold. First, it assesses the competitive conditions in the container shipping market. Industry competitiveness is of interest not only to academics but also to practitioners and policymakers, especially when considering competition policies. The method of calculating *H*-statistics has the advantage of setting clearer criteria for analyzing the market's competitive situation. By combining it with other information, such as freight rates, as in our analysis, academics, practitioners and policymakers can perform practical analyses of the container shipping market.

Second, this study fills a significant research gap. To the best of our knowledge, existing studies have researched container shipping market conditions on a shipping route basis and not on a shipping company level. Major container shipping companies do not use the same vessels in the same loop but use pendulum allocation and even interchange vessels between different routes. In addition, because alliances are formed on multiple routes, it is difficult to evaluate competition only by analyzing individual routes. This study overcomes these limitations by conducting an analysis on a firm-by-firm basis, which also shows that the container market is not monopolistic. As such, it complements existing literature in terms of research methods and is consistent with previous studies in terms of findings. This is a clear contribution to the understanding of the container market structure.

The current study has certain limitations. Since 2009, container vessels used in trunk routes have become larger, and competition in the industry has strengthened. This might have led to the recent industry consolidation. However, a comparative assessment of the competition level before and after the intervention could not be performed. This is a subject for future work. In addition, under the three alliance structures, the freight rates for container transport have increased significantly, especially after the second half of 2020; this must also be evaluated from the perspective of market structure. However, this remains a future issue.

Another issue concerns the nature of the  $H$ -statistic. Recently, it has been pointed out that the  $H$ -statistic is similar to the pass-through rate of firms (Sanchez-Cartas, 2020). In other words, it is the degree to which price changes of production factors are passed on to consumers. In addition, some studies suggest that the pass-through rate is affected by the shape of the demand and cost functions and therefore does not have a stable relationship with market dominance (Weyl and Fabinger, 2013). While  $H$ -statistics remains a prevailing methodology to assess competition situations, we believe it is necessary to continuously examine the limitations to reinforce the theory, which is an area for future studies.

Lastly, an examination of economies of scale in the container shipping market is of future interest. Merk *et al.* (2015) pointed out that economies of scale have become less effective in the increasingly large shipping industry, especially recently. Our analysis shows that even when the number of firms is decreasing, competition in the market intensifies, and from the perspective of profit maximization, there is no benefit in increasing size or market share. In this case, if economies of scale are at work, scale expansion through horizontal mergers is justified. However, it is not clear whether economies of scale work in the container shipping market. Future studies should examine if economies of scale in the container shipping market will add value.

## References

- Brander, J.A. and Zhang, A. (1993), "Dynamic oligopoly behaviour in the airline industry", *International Journal of Industrial Organization*, Vol. 11 No. 3, pp. 407-435.
- Claessens, S. and Laeven, L. (2004), "What drives bank competition? Some international evidence", *Journal of Money, Credit and Banking*, Vol. 36 No. 3b, pp. 563-583.
- Clarksons research (2021), "Shipping intelligence network database", available at: <https://www.clarksons.net/> (accessed 04 June 2021).
- Crotti, D., Ferrari, C. and Tei, A. (2020), "Merger waves and alliance stability in container shipping", *Maritime Economics and Logistics*, Vol. 22 No. 3, pp. 446-472.
- Endo, N. (2005), "Analysis of competitive nature of liner shipping industry", *Transport Policy Studies' Review*, Vol. 8 No. 3, pp. 42-48, (in Japanese).
- Fenn, P., Vencappa, D., Diacon, S., Klumpes, P. and O'Brien, C. (2008), "Market structure and the efficiency of European insurance companies: a stochastic frontier analysis", *Journal of Banking and Finance*, Vol. 32 No. 1, pp. 86-100.
- Fischer, T. and Kamerschen, D.R. (2003), "Measuring competition in the US airline industry using the Rosse-Panzar test and cross-sectional regression analyses", *Journal of Applied Economics*, Vol. 6 No. 1, pp. 73-93.
- Fusillo, M. (2006), "Some notes on structure and stability in liner shipping", *Maritime Policy and Management*, Vol. 33 No. 5, pp. 463-475.
- Ha, Y.S. and Seo, J.S. (2017), "An analysis of the competitiveness of major liner shipping companies", *Asian Journal of Shipping and Logistics*, Vol. 33 No. 2, pp. 53-60.
- Hirata, E. (2017), "Contestability of container liner shipping market in alliance era", *Asian Journal of Shipping and Logistics*, Vol. 33 No. 1, pp. 27-32.

- Hirata, E. (2018), "A non-structural approach to assess competitive conditions in container liner shipping market: 2009-2014", *International Journal of Shipping and Transport Logistics*, Vol. 10 Nos 5/6, pp. 500-513.
- Igami, M. and Uetake, K. (2020), "Mergers, innovation, and entry-exit dynamics: consolidation of the hard disk drive industry, 1996-2016", *The Review of Economic Studies*, Vol. 87 No. 6, pp. 2672-2702.
- Japan Maritime Center (2016), "Report of the committee on maritime economic affairs on the antimonopoly law exemptions for ocean shipping", (in Japanese), available at: [http://www.jpmac.or.jp/information/pdf/514\\_3.pdf](http://www.jpmac.or.jp/information/pdf/514_3.pdf) (accessed 25 July 2019).
- Kawasaki, T. and Matsuda, T. (2015), "Containerization of bulk trades: a case study of US-Asia wood pulp transport", *Maritime Economics and Logistics*, Vol. 17 No. 2, pp. 179-197.
- Matsuda, T., Hanaoka, S. and Kawasaki, T. (2020), "Cost analysis of bulk cargo containerization", *Maritime Policy and Management*, Vol. 47 No. 6, pp. 736-755.
- Matsumura, T. (2005), "H-statistics and competitiveness of the markets", *Journal of Social Sciences*, Vol. 56, pp. 43-51, (in Japanese).
- Merk, O., Busquet, B. and Aronietis, A. (2015), "The impact of mega-ships, case-specific policy analysis", available at: [https://www.itf-oecd.org/sites/default/files/docs/15cspa\\_mega-ships.pdf](https://www.itf-oecd.org/sites/default/files/docs/15cspa_mega-ships.pdf) (accessed 25 July 2019).
- Merk, O., Kirstein, L. and Salamitov, F. (2018), "The impact of alliances in container shipping, the international transport forum case-specific policy analysis 127", available at: <https://www.itf-oecd.org/sites/default/files/docs/impact-alliances-container-shipping.pdf> (accessed 25 July 2019).
- Midoro, R. and Pitto, A. (2000), "A critical evaluation of strategic alliances in liner shipping", *Maritime Policy and Management*, Vol. 27 No. 1, pp. 31-40.
- Murat, G., Tonkin, R.S. and Jüttner, D.J. (2002), "Competition in the general insurance industry", *Zeitschrift für die gesamte Versicherungswissenschaft*, Vol. 91 No. 3, pp. 453-481.
- Murjan, W. and Ruza, C. (2002), "The competitive nature of the Arab Middle Eastern banking markets", *International Advances in Economic Research*, Vol. 8 No. 4, pp. 267-274.
- Nathan, A. and Neave, E.H. (1989), "Competition and contestability in Canada's financial system: empirical results", *Canadian Journal of Economics*, Vol. 22 No. 3, pp. 576-594.
- Oum, T.H., Zhang, A. and Zhang, Y. (1993), "Inter-firm rivalry and firm-specific price elasticities in the deregulated airline markets", *Journal of Transport Economics and Policy*, Vol. 27 No. 2, pp. 171-192.
- Panayides, P.M. and Wiedmer, R. (2011), "Strategic alliances in container liner shipping", *Research in Transportation Economics*, Vol. 32 No. 1, pp. 25-38.
- Panzar, J.C. and Rosse, J.N. (1987), "Testing for "monopoly" equilibrium", *The Journal of Industrial Economics*, Vol. 35 No. 4, pp. 443-456.
- Sanchez-Cartas, J.M. (2020), "The Panzar-Rosse H statistic and monopoly. Issues on its use as a market power measure", *The BE Journal of Economic Analysis and Policy*, Vol. 20 No. 4, 20200193, doi: [10.1515/bejeap-2020-0193](https://doi.org/10.1515/bejeap-2020-0193).
- Savage, I. (1995), "Panzar and Rosse style tests of market structure in the US motor carrier industry", *Logistics and Transportation Review*, Vol. 31 No. 2, pp. 135-144.
- Shaffer, S. (1993), "A test of competition in Canadian banking", *Journal of Money, Credit and Banking*, Vol. 25 No. 1, pp. 49-61.
- Sheppard, E.J. and Seidman, D. (2001), "Ocean shipping alliances: the wave of the future?", *International Journal of Maritime Economics*, Vol. 3 No. 4, pp. 351-367.
- Slack, B., Comtois, C. and McCalla, R. (2002), "Strategic alliances in the container shipping industry: a global perspective", *Maritime Policy and Management*, Vol. 29 No. 1, pp. 65-76.

- 
- Song, D.W. and Panayides, P.M. (2002), "A conceptual application of cooperative game theory to liner shipping strategic alliances", *Maritime Policy and Management*, Vol. 29 No. 3, pp. 285-301.
- Sys, C., Meersman, H. and Van De Voorde, E. (2011), "A non-structural test for competition in the container liner shipping industry", *Maritime Policy and Management*, Vol. 38 No. 3, pp. 219-234.
- UNCTAD (2015), "Review of Maritime Transport 2015", available at: [https://unctad.org/en/PublicationsLibrary/rmt2015\\_en.pdf](https://unctad.org/en/PublicationsLibrary/rmt2015_en.pdf) (accessed 25 July 2019).
- Weyl, E.G. and Fabinger, M. (2013), "Pass-through as an economic tool: principles of incidence under imperfect competition", *Journal of Political Economy*, Vol. 121 No. 3, pp. 528-583.
- Yuan, Y. (2006), "The state of competition of the Chinese banking industry", *Journal of Asian Economics*, Vol. 17 No. 3, pp. 519-534.

**Corresponding author**

Takuma Matsuda can be contacted at: [tmatsuda@ner.takushoku-u.ac.jp](mailto:tmatsuda@ner.takushoku-u.ac.jp)

---

For instructions on how to order reprints of this article, please visit our website:

[www.emeraldgrouppublishing.com/licensing/reprints.htm](http://www.emeraldgrouppublishing.com/licensing/reprints.htm)

Or contact us for further details: [permissions@emeraldinsight.com](mailto:permissions@emeraldinsight.com)